

Total No. of Questions : 12]

SEAT No. :

P1616

[Total No. of Pages : 3

[4164] - 117

B.E. (Electronics)

DIGITAL IMAGE PROCESSING
(2003 Pattern) (Elective - II) (Sem. - II)

Time : 3 Hours]

[Max. Marks : 100

Instructions to the candidates :-

- 1) Answer 3 questions from Section I and 3 questions from Section II.
- 2) Neat diagrams must be drawn wherever necessary.
- 3) Figures to the right indicate full marks.
- 4) Assume suitable data, if necessary.

SECTION - I

- Q1)** a) With the help of illustration explain Mach band effect and simultaneous contrast. [8]
- b) What are the steps in image digitization? Explain image quantization in detail. [8]

OR

- Q2)** a) With the help of block diagram explain the fundamental steps in Digital Image Processing. [8]
- b) Give pictorial representation of pixel relationships. [6]
- c) Define: [2]
- i) MTF
 - ii) Profile of Image

- Q3)** a) Give the equation of 2D FFT. What are the properties of 2D DFT? Explain in detail. [10]
- b) For the given 2×2 image K find DCT and show that DCT preserves signal energy. [8]

$$K = \begin{bmatrix} 2 & 2 \\ 1 & 2 \end{bmatrix}$$

$$\begin{bmatrix} 1 & 2 \end{bmatrix}$$

OR

P.T.O.

Q4) a) With reference to HSI color model explain how RGB can be converted to HSI and vice-versa. [8]

b) Explain Walsh Transform in detail. [10]

Q5) a) Explain image histogram with the help of an example. What are the applications of Histogram. [8]

b) Explain: [8]

i) Image subtraction

ii) Averaging filter in spatial domain.

OR

Q6) a) Define High Pass filter in frequency domain. Differentiate between Butterworth High pass and Gaussian High Pass filter. [8]

b) Compute the median value of the four marked pixels (marked by a*) shown in figure using 3×3 mask. [8]

$$F(m,n) = \begin{vmatrix} 18 & 22 & 33 & 25 & 32 & 24 \\ 34 & 128^* & 24^* & 172^* & 26^* & 23 \\ 22 & 19 & 32 & 31 & 28 & 26 \end{vmatrix}$$

SECTION - II

Q7) a) With the help of neat block diagram explain Lossy Predictive Coding. [10]

b) Find the set of codewords and average word length using Huffman coding scheme for a set of gray levels with probabilities given below. [8]

Input	G1	G2	G3	G4	G5	G6	G7	G8
Probability	0.03	0.05	0.02	0.15	0.05	0.15	0.25	0.3

OR

Q8) a) With the help of block diagram explain Transform coding. What are its advantages over spatial coding? [10]

b) Explain RLC coding and arithmetic coding with examples. [8]

Q9) a) Given 10×10 image I, perform dilation using structuring element J given as follows

$$I = \begin{pmatrix} 0 & 0 & 0 & 0 & 0 & 0 & 0 & 0 & 0 & 0 \\ 0 & 0 & 0 & 0 & 0 & 0 & 0 & 0 & 0 & 0 \\ 0 & 0 & 1 & 1 & 1 & 1 & 1 & 1 & 0 & 0 \\ 0 & 0 & 1 & 1 & 1 & 1 & 1 & 1 & 0 & 0 \\ 0 & 0 & 1 & 1 & 0 & 0 & 1 & 1 & 0 & 0 \\ 0 & 0 & 1 & 1 & 0 & 0 & 1 & 1 & 0 & 0 \\ 0 & 0 & 1 & 1 & 1 & 1 & 1 & 1 & 0 & 0 \\ 0 & 0 & 1 & 1 & 1 & 1 & 1 & 1 & 0 & 0 \\ 0 & 0 & 0 & 0 & 0 & 0 & 0 & 0 & 0 & 0 \\ 0 & 0 & 0 & 0 & 0 & 0 & 0 & 0 & 0 & 0 \end{pmatrix} \quad [8]$$

$$J = \begin{pmatrix} 1 & 1 \\ 1 & 1 \end{pmatrix}$$

- b) Find the expression for the signatures of following boundaries and plot the signatures. . [8]
- Square
 - Equilateral Triangle

OR

- Q10)a)** What is skeletonization? Give its algorithm. [8]
- b) What is thresholding? What is the role of illumination in thresholding? [8]

- Q11)a)** Give the basic model of the image degradation/Restoration Process. [8]
- b) What are the features extracted for fingerprint recognition? Explain the recognition process. [8]

OR

- Q12)a)** Define the following noise density functions : [8]
- Gaussian noise
 - Rayleigh noise
 - Erlang noise
 - Uniform noise
- b) Explain one spatial filter for restoration in the presence of noise. [8]

⌘⌘⌘

Total No. of Questions : 12]

SEAT No. :

P1618

[Total No. of Pages : 2

[4164] - 142

B.E. (Instrumentation)

PROJECT ENGINEERING & MANAGEMENT

(1997 & 2008 Course) (406262)

Time :3 Hours]

[Max. Marks :100

Instructions to the candidates :-

- 1) *Answers to the two sections should be written in separate books.*
- 2) *Neat diagrams must be drawn wherever necessary.*
- 3) *Figures to the right indicate full marks.*
- 4) *Assume suitable data, if necessary.*
- 5) *All question are compulsory.*

SECTION - I

- Q1)** a) What is the project statement? Elaborate the role of project team in forming. [8]
- b) What is line organization structure, structure, Explain in detail? Draw an organizational structure for any consultation firm. [10]

OR

- Q2)** a) Explain various organizational structures in detail. [10]
- b) Write a short note on multiagency interaction involved in project. [6]
- c) What is project management? [2]

- Q3)** a) Prepare Technical specification sheet in s-20 format. [8]
- i) Magnetic flow meter
- ii) Differential pressure instrument
- b) What si P&ID.? Draw the P&ID for fractionators. [8]

OR

- Q4)** a) Explain with suitable example scope of material balance sheet. [8]
- b) Mention the standards used in instrumentation project. Explain one. Also explain the method of tagging and its importance. [8]

P.T.O.

- Q5)** a) Write the selection criteria for cables with respect to application. [8]
b) Explain the importance of installation sketches. Draw an installation sketch for differential pressure sensing flow transmitter. [8]

OR

- Q6)** a) What is BOM and MBOM? Write its importance. [8]
b) What is loop wiring diagram explain with neat diagram? [6]

SECTION - II

- Q7)** a) What is FAT, SAT & CAT? Prepare a FAT for control panel. [12]
b) Give the classification of CAT cable. Also state its applications. [6]

OR

- Q8)** a) List and explain the documents required during construction activity. [12]
b) What is Tendering? Explain it in detail. [6]

- Q9)** a) What is Intelligent operator Interface? Explain its features in detail. [8]
b) Design a control panel for Boiler assuming 3 element drum level control and air-fuel ratio control. [8]

OR

- Q10)** a) Explain the inspection Procedure for Pneumatic Control Panel. [8]
b) Explain breakfront of control panel with neat sketch. Write advantages and disadvantages of using it. [8]

- Q11)** a) What is PERT? Explain it with example. [6]
b) Write Notes : [10]
i) Project specifications
ii) Pricing process in brief.

OR

- Q12)** a) List out various documents involved in project management. Explain SOW and WBS in detail. [10]
b) What are different softwares used in project management? Explain any one in detail. [6]



Total No. of Questions : 12]

SEAT No. :

P1715

[Total No. of Pages : 3

[4164] - 199

B.E. (Chemical Engineering)
PIPING DESIGN & ENGINEERING
(2003 Pattern) (Sem. - II) (Elective - II)

Time :3 Hours]

[Max. Marks :100

Instructions to the candidates :-

- 1) *Answer 3 questions from Section I and 3 questions from Section II.*
- 2) *Answers to the two sections should be written in separate books.*
- 3) *Neat diagrams must be drawn wherever necessary.*
- 4) *Figures to the right indicate full marks.*
- 5) *Assume suitable data, if necessary.*

SECTION - I

- Q1) a)** 0.75 liter per minute of ethyl alcohol flows a 20 °C through a 15 mm diameter 10 m long stainless steel drawn tubing ($k_s = 1.64 \times 10^{-6}m$). The kinematic viscosity of the fluid at 20 °C is $1.77 \times 10^{-6} m^2/s$. Determine the head loss and power consumption. Specific gravity of ethyl alcohol is 0.79. **[8]**
- b) Explain the following terms : **[8]**
- i) Pipe Sizing
 - ii) Economic velocity

OR

- Q2) a)** Derive the following, $\Delta Q = \frac{-\sum r.Q_o^n}{\sum r.n.Q_o^{n-1}}$ **[8]**
- b) A pipe 50 mm diameter is 6 m long and the velocity of flow of water in the pipe is 2.4 m/s. What loss of head and the corresponding power would be saved if the central 2 m length of pipe was replaced by 75 mm diameter pipe, the change of section being sudden? Take $f=0.04$ for the pipes of both diameters. **[8]**

- Q3) a)** Explain in detail the following types of flanges **[6]**
- i) Threaded Flange
 - ii) Orifice Flange

P.T.O.

- b) List out the major standards providing engineering bodies in piping? Explain most Commonly used piping components and their dimensional standards? [10]

OR

- Q4)** a) Discuss the various types of gasket according to ASME B16.5 and B16.47 for flanges? [8]

- b) What are the desirable properties of piping materials for low temperature and high temperature services? [8]

- Q5)** a) Describe the construction and principle of operation for the following types of valve actuators : [10]

i) Pneumatic

ii) Hydraulic

iii) Solenoid

- b) Discuss the sizing of pressure relief valves for gas or vapor based on the ideal gas law? [8]

OR

- Q6)** a) What are the steps followed during sizing of control valve? [10]

- b) State and explain two major types of rupture discs made of ductile metal? [8]

SECTION - II

- Q7)** a) Explain the different types of two phase flow system with suitable model equations? [8]

- b) Explain the correct piping arrangement with the help of submergence laws for centrifugal pump? [8]

OR

- Q8)** a) Explain the detailed description of design principles and line sizing for vacuum pipelines? [8]

- b) Discuss steam pipe sizing based on flowrate and maximum velocity of the steam or pressure drop? [8]

- Q9)** a) Explain the types of plot plan and their advantages? [8]

- b) Which are the factors considered when the designer is locating equipment in the plot plan? [10]

OR

- Q10)** a) Discuss in detail the typical layout considerations for storage tanks?[10]
b) Explain the various considerations involved in pipe rack design? [8]

- Q11)** a) Discuss the responsibilities of piping engineer? [8]
b) What are the most common insulation material classifications in the industrial and commercial piping industry? [8]

OR

Q12) Write short notes on : [16]

- a) Hot & cold insulation in piping.
- b) High alloy steel & its usage in piping.
- c) List of documents for preparation of layout for a process plant.
- d) Critical thickness of insulation.



Total No. of Questions : 12]

SEAT No. :

P1611

[Total No. of Pages : 4

[4164] - 30

B.E. (Mechanical Engineering)
COSTING AND COST CONTROL
(2003 Pattern) (Sem. - I) (Elective - I)

Time : 3 Hours]

[Max. Marks : 100

Instructions to the candidates :-

- 1) *Answer any one question from each unit.*
- 2) *Answers to the two sections should be written in separate books.*
- 3) *Neat diagrams must be drawn wherever necessary.*
- 4) *Figures to the right indicate full marks.*
- 5) *Use of electronic pocket calculator allowed.*
- 6) *Assume suitable data, if necessary.*

SECTION - I

Unit - I

- Q1)** a) Distinguish between financial accounting and cost accounting? [6]
b) What are the limitations of financial accounting? [4]
c) Distinguish between : [6]
i) Prime cost and conversion cost.
ii) Controllable and uncontrollable cost.

OR

- Q2)** a) Distinguish between direct labor and indirect labor cost? Give four examples of indirect labor that may arise in factory? [8]
b) Discuss the various costs used in decision making and explain their characteristics. [8]

Unit - II

- Q3)** a) Elucidate the meaning and formulation of "Product cost" for the purpose of income measurement and determination of financial position. [8]
b) Explain the following with examples. [8]
i) Expired cost and unexpired cost.
ii) Direct material cost and indirect material cost.

OR

P.T.O.

Q4) a) M/s XYZ Ltd. are the manufacturers of moon-light torches. The following data relate to manufacture of torches during the month of March 1991 : **[12]**

Raw material consumed	: Rs. 20,000
Direct wages	: Rs. 12,000
Machine-hour worked	: 9,500 hours
Machine-hour rate	: Rs. 2
Office overheads	: 20% of work cost
Selling overheads	: Rs. 0.50 per unit
Units produced	: 20,000
Units sold	: 18,000 @ Rs. 5 per unit

Prepare cost sheet showing the cost and the profit per unit and the total profit earned.

b) Distinguish between cost control and cost reduction. **[4]**

Unit - III

Q5) a) Overhead costs are usually classified according to variability. What are the necessities for such classification and what purpose do such classification serve? **[10]**

b) Distinguish between cost allocation, cost apportionment and cost absorption? **[8]**

OR

Q6) a) Distinguish between 'standard costing system' and 'budgetary control'? **[6]**

b) Discuss briefly the use of standard costs in the following management activities : **[6]**

- i) cost reductions
- ii) operating performance
- iii) product pricing decisions

c) What are the different types of labor variances? How are they calculated? **[6]**

SECTION - II

Unit - IV

- Q7)** a) What are joint costs? What problems are created by joint costs? [8]
b) Explain the various bases available for apportionment of joint costs to joint products? [8]

OR

- Q8)** a) State whether the following statements are **True** or **False** [4]
- i) Process costing is suitable for chemical factories.
 - ii) Normal loss is absorbed in good units in process costing.
 - iii) The main product of one industry may be the by-product in another.
 - iv) Raw material costs are always post-separation costs.
- b) Discuss the distinguishing features of process costing system? [6]
c) Explain the procedure of accounting for by-products? [6]

Unit - V

- Q9)** a) Explain the terms 'Margin of Safety' and 'Angle of incidence' in break even analysis. Illustrate your answer graphically? [8]
b) The profit/volume ratio of Escorts Ltd. is 50% and the margin of safety is 40%. Calculate the net profit and the break even point if sales volume is Rs. 10,00,000. [10]

OR

- Q10)** a) Discuss the following terms in relation to marginal costing : [6]
- i) Key factor
 - ii) P/V ratio
- b) The following data is given : [12]
Fixed expenses = Rs. 1,00,000;
Variable expenses = Rs. 10 per unit;
Selling price = Rs. 15 per unit
Evaluate the number of units to be manufactured and sold
- i) To Break even
 - ii) To earn a profit of Rs. 10,000
- What additional units be necessary to increase the above profit by Rs. 5000?

Unit - VI

- Q11)a)** What is a cost driver? What is the role of cost driver in tracing costs to products? [5]
- b) What is Activity Based Costing? Explain its significance? [6]
- c) Explain the meaning of a business budget? How does it serve as an instrument of control? [5]

OR

- Q12)a)** Write short note on : [9]
- i) Material usage variance
- ii) Overhead variance
- iii) Sales variance
- b) Explain in brief the ‘two variance analysis’ of factory overheads. [7]



Total No. of Questions : 12]

SEAT No. :

P1612

[Total No. of Pages : 3

[4164] - 50-A

B.E. (Mechanical) (Mechanical S/W)

NON - CONVENTIONAL ENERGY SOURCES

(Sem. - II) (2003 Pattern) (Elective - III)

Time :3 Hours]

[Max. Marks :100

Instructions to the candidates :

- 1) *Answer 3 questions from Section - I and 3 questions from Section - II.*
- 2) *Answers to the two sections should be written in separate books.*
- 3) *Neat diagrams must be drawn wherever necessary.*
- 4) *Figures to the right indicate full marks.*
- 5) *Use of logarithmic tables, slide rule, Mollier Chart, electronic pocket calculator and steam tables is allowed.*

SECTION - I

- Q1)** a) Discuss the merits and demerits of alternative energy sources over the currently used energy sources. **[8]**
- b) Define Beam & Diffuse radiation. What is Local Apparent Time and why it is different than standard time observed on a clock. Give the equation for Local Apparent Time. **[9]**

OR

- Q2)** a) Define Altitude angle, Surface Azimuth angle, Solar azimuth angle, Hour angle. Calculate the angle made by beam radiation with the normal to a flat-plate collector on December 1 at 0900 h (local apparent time). The collector is located in New Delhi (28°35'N, 77°12'E), and is tilted at angle of 36° with the horizontal and is pointing due south. **[9]**
- b) Explain the working of Radiation Pyranometer with neat sketch. **[8]**

- Q3)** Explain the working of conventional liquid flat plate collector with neat sketch. Give the energy balance for the absorber plate and define the instantaneous collector efficiency. Explain briefly the various loss coefficients. **[17]**

OR

P.T.O.

- Q4)** a) Discuss in brief the applications of solar air heating. [6]
b) What is the significance of selective surface used in flat plate collectors? Enlist some selective surfaces. [4]
c) Why collector heat removal factor important in the model for flat plate collector? [7]

- Q5)** a) Write the limitations of flat plate collectors and advantages of concentrating solar collectors. State the different types of concentrator used. [8]
b) Explain the working of solar pond and effect of various parameters on its performance. [8]

OR

- Q6)** Write short notes on : [16]
a) Solar still
b) Heliostats
c) Materials for concentrators and reflecting surfaces
d) Pyrheliometer

SECTION - II

- Q7)** What is the basic principle of solar photovoltaic (PV) power generation? What are the main elements of a PV system? What are the advantages and disadvantages of photovoltaic solar energy conversion? [17]

OR

- Q8)** What is the basic principle of wind energy conversion? Describe the main consideration in selecting a site for wind generators. Explain with neat sketch wind electric generation system. [17]

- Q9)** Explain the features of geothermal energy, its application, advantages and disadvantages. [17]

OR

- Q10)**a) What is the basic principle of ocean thermal energy conversion (OTEC). [4]
b) Explain how we get the energy from tides? [6]
c) What is fuel cell? Explain the principle of operation of fuel cell. [7]

Q11)a) Describe floating dome type of biogas plant. State advantages and limitations of floating drum type and fixed dome type biogas plant. [8]

b) Explain the methods of obtaining Energy from biomass. [8]

OR

Q12) Write short notes on following : [16]

a) Biogas for diesel engine

b) Biomass gasification

c) Micro Hydel power plant

d) Environmental protection norms ISO 14000.

⌘⌘⌘

Total No. of Questions : 12]

SEAT No. :

P1800

[Total No. of Pages : 2

[4164] - 278

B.E. (IT)

SYSTEM OPERATION AND MAINTENANCE

(2003 Pattern) (Sem. - II)

Time : 3 Hours]

[Max. Marks : 100

Instructions to the candidates:

- 1) *Answers to the two sections should be written in separate answer books.*
- 2) *From section I answer Q.1 or Q.2, Q.3 or Q.4, Q.5 or Q.6 and answer Q.7 or Q.8, Q.9 or Q.10, Q.11 or Q.12.*
- 3) *Neat diagrams must be drawn wherever necessary.*
- 4) *Figures to the right indicate full marks.*

SECTION - I

- Q1)** a) Classify telecom service providers. **[5]**
b) With a neat diagram explain the organizational structure of an average telecom service provider. **[5]**
c) Explain the service delivery cycle with a neat diagram. **[8]**
- OR
- Q2)** a) Write a short note on 'network operational management'. **[9]**
b) List the key features of the following: **[9]**
i) Customer care and billing process.
ii) Order processing and provisioning process.
- Q3)** a) Explain the concept of local number portability. **[8]**
b) Explain the following in short: **[2 × 4 = 8]**
i) Switched Virtual circuits
ii) Semi permanent Virtual circuits
- OR
- Q4)** a) What is LDAP? Explain its features and limitations in short. **[8]**
b) With the reference of SNMP protocol explain the following. **[8]**
i) Traditional SNMP manage
ii) RMON

P.T.O.

- Q5) a)** With a neat diagram explain MPLS. [8]
b) Explain in detail web switching. [8]

OR

- Q6) a)** What are the sources of information of IP billing? List the challenges and solutions in IP billing. [8]
b) Explain in short [8]
i) WAP ii) B2C
iii) GPS iv) Non source routing

SECTION - II

- Q7) a)** What is SLA? List some service dependent and service independent metrics. [9]
b) Customer care is a typical front office function explain. [9]

OR

- Q8) a)** Explain ATM and ISDN. [12]
b) List the website design considerations for a service provider's website. [6]

- Q9) a)** Write a note on common information model. [8]
b) List the strengths and weaknesses of SNMP based management services. [8]

OR

- Q10) a)** Explain the significance of periodic security audit for a telecommunication service provider. [8]
b) Draw a neat diagram of generic architecture of micro payment. [8]

- Q11) a)** How a service provider highlights gaps in the business process, tools, standards and human resource? Explain it in short. [8]
b) Explain internet billing process in short. [8]

OR

- Q12) a)** Write a job profile of a typical network operation manager. [8]
b) Draw a neat diagram of the architecture for business data collection, processing and distribution. [8]



Total No. of Questions : 12]

SEAT No. :

P1194

[Total No. of Pages : 3

[4164] - 53

B.E. (Production) (Common to Prod. S/W)
MANUFACTURING AUTOMATION AND CONTROL
(2003 Pattern) (Sem. - I)

Time :3 Hours]

[Max. Marks :100

Instructions to the candidates:-

- 1) *Answer any 3 questions from each section.*
- 2) *Answers to the two sections should be written in separate books.*
- 3) *Neat diagrams must be drawn wherever necessary.*
- 4) *Figures to the right indicate full marks.*
- 5) *Use of logarithmic tables slide rule, Mollier charts, electronic pocket calculator and steam tables is allowed.*
- 6) *Assume suitable data, if necessary.*

SECTION - I

- Q1)** a) Explain with neat sketch the radial piston pump and also derive an expression for its flow. [6]
- b) For a 100 kN press tool weight 5kN. Calculate the pressure required for pressing operation if bore diameter of cylinder is 80 mm, rod area is 60 mm and counter balance valve is used in circuit. [6]
- c) Explain with neat sketch basic principles of Hydraulics. [6]

OR

- Q2)** a) A pump has a displacement of 20 cm³/ rev. is driven at 1440 rpm and 120 bars. The volumetric efficiency is 0.90 and overall efficiency is 0.8. Calculate: [6]
- i) Pump delivery in liters per minute.
 - ii) The input power at pump shaft in kW.
 - iii) Drive torque at pump shaft.
- b) Explain with neat sketch flow dividers. [6]
- c) Explain with neat sketch, the working of unloading valve and draw typical circuit showing its application. [6]

P.T.O.

- Q3)** a) A hydraulic intensifier increases the pressure of water from 45 bars to 180 bars. The plunger of intensifier has a stroke length of 1.6m; storage capacity of intensifier is 30 liters. Determine the diameter of plunger. Also find the volume of high pressure water and low pressure water from the intensifier. [6]
- b) Explain with neat sketch cylinder synchronizing. [6]
- c) Discuss accumulators and intensifiers used hydraulics. [4]

OR

- Q4)** a) A cylinder has to exert forward thrust of 150 kN & reverse thrust of 20 kN. The cylinder extend speed is 0.5 m/min & retract speed is 6m/min. full pump flow is utilized during retraction of the cylinder. The maximum pump pressure is 150 bars & pressure drop across various elements is as below. Filter - 4 bar, DCV (each flow path) - 2 bar, FCV (controlled flow) - 10 bar, FCV (control variable) - 3 bar. Find out the efficiencies of meter - in and meter - out circuit and compare. Assume 2 : 1 ratio of piston area to piston rod ratio. [10]
- b) Explain with neat sketch the hydraulic circuit to maintain constant feed rate with variation in load. [6]

- Q5)** a) Explain with neat sketch the construction and working principle of pressure regulator. [6]
- b) Draw a pneumatic circuit showing the application of Quick Exhaust valve and explain its working. [6]
- c) Discuss the air treatment process in pneumatics system. [4]

OR

- Q6)** a) Draw & explain the working of a pneumatic circuit to actuate the two cylinders in the sequence $A^+ B^+ B^- A^-$ [8]
- b) Discuss with suitable example electro pneumatics. [8]

SECTION - II

- Q7)** a) Sketch the general architecture of microprocessor and explain the internal operation & registers of 8085 microprocessor. [10]
- b) Explain with suitable example computer process control system & its components. [8]

OR

- Q8)** a) Explain with block diagram microcontroller and briefly discuss the factors for selecting microcontroller. [8]

- b) Devise a circuit that could be used with a conveyor belt which is used to move an item to a workstation. The presence of item at workstation is detected by means of breaking a contact activated by a beam of light to a photo sensor. There it stops for 100s for an operation to be carried out before moving on and off the conveyor. The motor for the belt is started by NO start switch and stopped by a NC switch. [10]

- Q9)** a) Draw the neat sketches showing the characteristics of various controllers and write the equations for their output. [10]
 b) Explain with suitable example the use of counters & timers in PLC. [6]

OR

- Q10)** a) A PD controller has $K_p = 2.0$, $K_D = 2s$. Controller output for zero error is 40%. Plot the controller output for the error shown in figure. 1. [8]

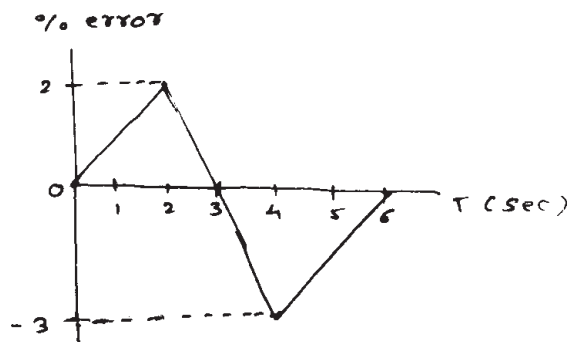

Fig. 1

- b) Discuss briefly PLC programming languages and process scan process.[8]

- Q11)** a) What factors should be considered while deciding the type of transfer device to be used in automated system? [4]
 b) Explain various transfer mechanisms used in automated systems. [6]
 c) Explain with neat sketches various types of feeders. [6]

OR

- Q12)** Write short notes on : [16]

- Automated warehouse.
- Industrial robots.
- Low cost automation.
- Design for assembly.



Total No. of Questions : 12]

SEAT No. :

P1196

[Total No. of Pages : 4

[4164] - 60

B.E. (Production Engineering)

PROCESS PLANNING AND TOOL SELECTION

(2003 Pattern) (Sem. - II)

Time : 3 Hours]

[Max. Marks : 100

Instructions to the candidates:-

- 1) *Answer any 3 questions from each section.*
- 2) *Answers to the two sections should be written in separate books.*
- 3) *Neat diagrams must be drawn wherever necessary.*
- 4) *Figures to the right indicate full marks.*
- 5) *Assume suitable data, if necessary.*
- 6) *Use of electronic pocket calculator is allowed.*

SECTION - I

- Q1)** a) "What is process? Explain with a neat line diagram how the Manufacturing processes are classified? [8]
- b) Define the following terms : [8]
- i) Part and work - piece.
 - ii) Equipment and tooling.
 - iii) Operation and routing.
 - iv) Specification and dimensions.

OR

- Q2)** a) List the main responsibilities of process engineer. [8]
- b) What are the considerations for manufacturing and assembly operation while designing a product. [8]
- Q3)** a) What are the two methods of dimensioning? Which method is normally preferred and why? [8]
- b) What is a datum? What is the advantage of using datum? Is it always possible to establish a physical datum? Explain. [8]

OR

- Q4)** a) What is meant by geometry of form? Define the followings :- [8]
- i) Flatness,
 - ii) Straightness,
 - iii) Angularity,
 - iv) Concentricity.

P.T.O.

b) What is the purpose of grouping the related surfaces or areas? Explain. [8]

Q5) a) What do you mean by selective assembly? Explain the three general types of fits with appropriate examples? [9]

b) What causes work - piece variations? What are the variables which interface with work - piece control? [9]

OR

Q6) a) What are the design and process tolerance stack? Explain with suitable example. List the problems incurred due to tolerance stack. [9]

b) What are the rules for locating long cylinder and short cylinder? Explain with neat diagram. [9]

SECTION - II

Q7) a) Discuss various factors affecting on selection of tooling. [8]

b) Differentiate between general purpose machine (GPM) and special purpose machine (SPM). List any four GPM's. [8]

OR

Q8) a) What is mean by process capability of equipment? Explain and differentiate between prime accuracies and producing accuracies. [8]

b) Compare and explain various types of holders used for cylindrical tools. [8]

Q9) a) Explain in detail the steps involved in variant process planning. List CAPP software packages used in manufacturing industry. [8]

b) How are the critical areas on a work - piece generally identified? Distinguish between product critical areas and process critical areas. Which is most likely to occur in operation sequence? [8]

OR

Q10) a) Explain Automatic Time Standard System (ATS) in CAPP? [8]

b) Describe the steps of the engineering approach to selecting and planning a process. [8]

Q11) A precision Engineering Company have won a contract to manufacture 5000 units of a component as shown in figure1., with a view to repeat orders every two months. The holes are to be produced on a manual drill press and have to ensure required accuracy and repeatability. Prepare a process sheet for a component to have a minimum cost per piece. [18]

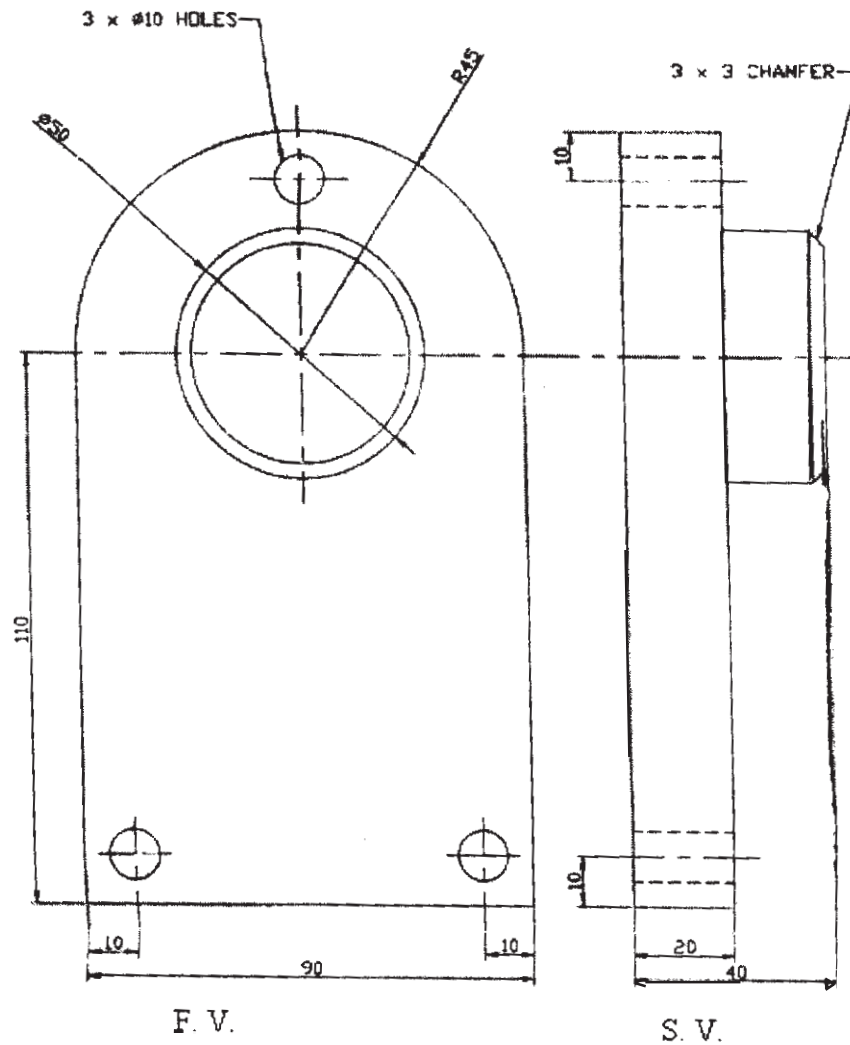

Fig. 1. Machined Component.

All dimensions are in mm.

General tolerance ± 0.1 unless otherwise stated.

Quantity	Material	Scale
5000	Mild Steel	1 : 1

OR

Q12) The part drawing shown in fig. 2, shows a flanged component is to be manufacture in batches of size 500, at an intervals of two weeks. Prepare the process sheet containing manufacturing plan with operation sequence, equipments, tooling, process parameters and cycle time per piece. [18]

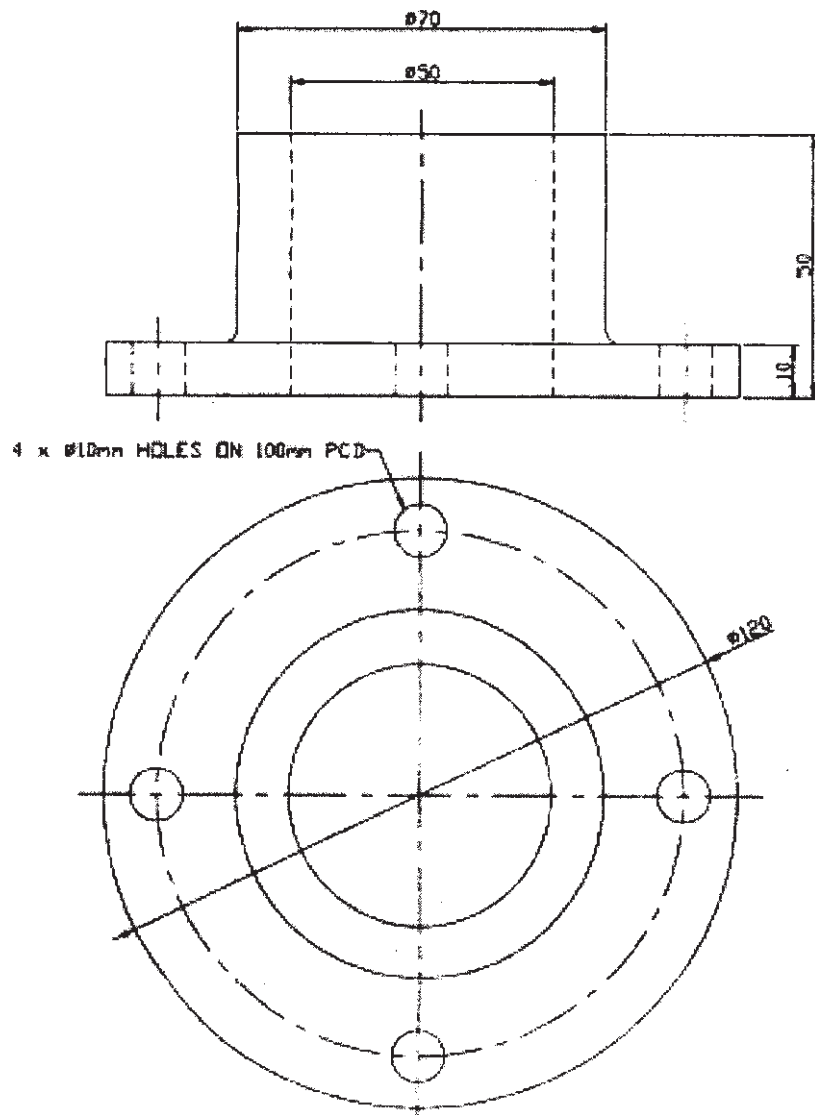

Fig. 2. Flange

All dimensions are in mm.

General tolerance ± 0.5 unless otherwise stated.

Quantity	Material	Scale
500	Cast Iron	1 : 1



Total No. of Questions : 12]

SEAT No. :

P1197

[Total No. of Pages : 3

[4164] - 61

B.E. (Production Engineering)

CAD/CAM/CIM

(2003 Pattern) (Sem. - II)

Time :3 Hours]

[Max. Marks :100

Instructions to the candidates:-

- 1) *Attempt one question of each unit from Section - I and Section - II.*
- 2) *Answer to the questions should be written on separate books.*
- 3) *Draw neat diagrams wherever necessary.*
- 4) *Assume suitable data if required.*

SECTION - I

Unit - I

- Q1)** a) Perform the following transformation if the coordinates of vertices of triangle are A(2,2), B(6,2), C(4,6) the transformation in sequence are
- i) Scaling by 2 units in X and Y direction.
 - ii) Rotate by 30 degree anticlockwise about A, [8]
- b) Explain image creation techniques in cad [8]

OR

- Q2)** a) Explain different surface entities. [6]
- b) A line XY with end points X(2,2) and Y(5,5) find new co-ordinates of a line for following transformation
- i) Translate X 2 unit and Y 3 unit,
 - ii) Scale in X and Y direction by 2,
 - iii) Rotate by 45 degree in CCW,
 - iv) Reflection about origin. [10]

Unit - II

- Q3)** a) Why tool presetting is required for CNC? Explain the set up with sketch. [6]
- b) Explain different layouts in FMS. [6]
- c) Explain sub routine and Do loop used in CNC programming. [6]

OR

P.T.O.

- Q4)** a) Write a note on [8]
 i) automated factory,
 ii) CANQ.
- b) Write a CNC program in G and M code for a part as shown in fig No.1. Also write a remark for each block. [10]

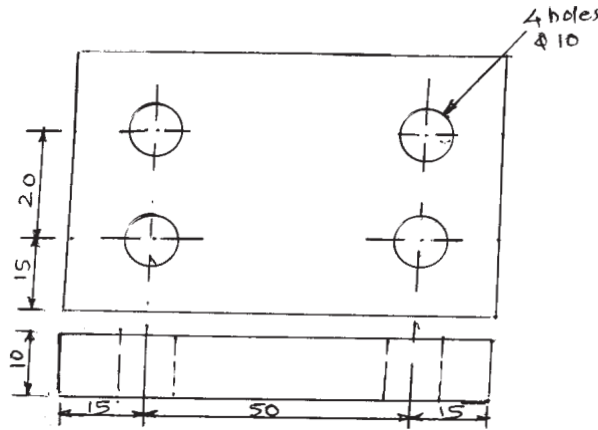

Unit - III

- Q5)** a) Explain different phases in ERP. [8]
 b) Explain basic data required to prepare a CIM database. [8]
 OR
- Q6)** a) Explain different robot configuration. [8]
 b) Explain any two manufacturing module in MRP - II. [8]

SECTION - II

Unit - IV

- Q7)** a) Why is RP used? Give the details of any one RP process. [8]
 b) Compare stereolithography RP with selective sintering. [7]
 OR
- Q8)** a) Explain basic methodology for getting a product through 3D printing process? [8]
 b) Explain with neat sketch fused deposition RP. State its advantages, limitations. [7]

Unit - V

- Q9)** a) Explain optiz coding system. [8]
 b) Explain different steps to be followed for solving truss problem using FEA. [6]
 c) Explain with suitable example the use of production flow analysis for cell formation. [6]

OR

- Q10)** a) A stepped bar is made of two materials joined together as shown in following figure no.2. The bar is subjected to an axial pull of 20kN. Determine the displacement, reaction force at support, stress of each of the section using a 1D spar element. [14]

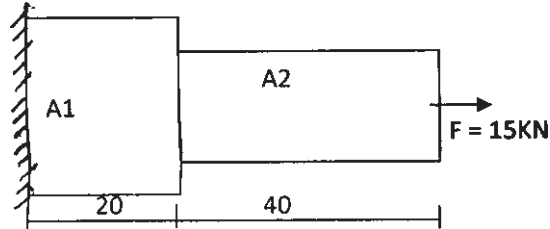

$$A1 = 70 \text{ mm}^2, E1 = 200 \text{ GPa}, A2 = 35 \text{ mm}^2, E2 = 120 \text{ GPa}.$$

- b) Explain mesh generation and model building in FEA. [6]

Unit - VI

- Q11)** Write short note on [15]

- a) Rapid product development,
- b) QFD,
- c) Enterprise optimization.

OR

- Q12)** a) Explain ESPRIT Model in brief. [8]
b) Explain NIST - AMRF Hierarchical model. [7]



Total No. of Questions : 12]

SEAT No. :

P1198

[Total No. of Pages : 2

[4164] - 63

B.E. (Production)

ERGONOMICS AND HUMAN FACTORS IN ENGINEERING

(2003 Pattern) (Elective - II) (Sem. - II)

Time :3 Hours]

[Max. Marks :100

Instructions to the candidates:-

- 1) *Answer 3 questions from Section I and 3 questions from Section II.*
- 2) *Answers to the two sections should be written in separate books.*
- 3) *Neat diagrams must be drawn wherever necessary.*
- 4) *Figures to the right indicate full marks.*
- 5) *Assume suitable data, if necessary.*

SECTION - I

- Q1)** a) Explain the basis of ergonomic problem identification. [8]
b) What are Human Machine systems? Explain its types and characteristics.[10]

OR

- Q2)** a) Explain the Lumbar Lordosis Principle used in seat design. [6]
b) Explain Work & Rest cycle. [6]
c) Explain the criterion for safe MMH Task design. [6]

- Q3)** a) What is Anthropometry and explain principles used in application of Anthropometric data. [8]
b) Explain the considerations in designing a seated workplace. [8]

OR

- Q4)** a) Explain different types of anthropometric dimensions and describe the concept of percentiles used in anthropometric data. [8]
b) What are the requirements for designing safe product? [8]

- Q5)** Explain arrangement of following components at work place (any FOUR)[16]
a) Visual displays
b) Control on panels
c) Hand controls.
d) Two hand controls.
e) Foot controls.
f) Controls that require force.

P.T.O.

OR

- Q6)** Write short note on (any TWO). **[16]**
- a) Hand tool design.
 - b) Functions of controls.
 - c) Concept of visibility.
 - d) Location of controls in work place.

SECTION - II

- Q7)** a) Write a note on different hot temperature indices. **[9]**
b) Differentiate between Discomfort glare & Disability glare. **[9]**

OR

- Q8)** a) What are the effects of excessive noise levels. What are the techniques of noise reduction. **[9]**
b) Explain the physiological effects of heat & cold. Explain its remedies. **[9]**
- Q9)** a) Discuss the effect of lighting on elderly? Explain its any two effects of heat on human performance. **[12]**
b) Explain the significance of warnings in brief. **[4]**

OR

- Q10)** a) Explain the term Accident. Explain its relationship with human errors. **[8]**
b) Explain perception of risk & describe risk evaluation process. **[8]**
- Q11)** a) Explain MOST and its types in brief. **[8]**
b) Explain the various considerations used in MTM 1 **[8]**

OR

- Q12)** Explain the following PMTS (Predetermined Motion Time Analysis) Determine the variants & stability of each. **[16]**
- a) Work factor system.
 - b) Method Time measurement.



Total No. of Questions : 12]

SEAT No. :

P1200

[Total No. of Pages : 2

[4164] - 64

B.E. (Production)

ADVANCED MATERIAL PROCESSING

(Elective - II) (2003 Pattern) (Sem. - II)

Time : 3 Hours]

[Max. Marks : 100

Instructions to the candidates:

- 1) *Attempt one question of each unit from Section - I and Section - II.*
- 2) *Answer to the sections should be written in separate books.*
- 3) *Neat diagrams must be drawn wherever necessary.*

SECTION - I

Unit - I

- Q1)** a) Explain the concept of hard turning process and compare it with conventional turning process. [8]
b) Explain the chip morphology in High speed machining. [8]

OR

- Q2)** a) Explain the ultrasonic vibration assisted machining. [8]
b) Explain the development of tool geometry for insert. [8]

Unit - II

- Q3)** a) State the requirement of dielectric fluid used in EDM? Explain metal removal in EDM. [8]
b) Explain with neat sketch thermal energy process. [8]

OR

- Q4)** a) For a Rc Ckt adjusted for maximum power supply, following details available, Resistance $R = 380 \text{ Ohm}$, Capacitance $C = 50 \text{ microfarad}$, Supply voltage = 80 V. Calculate charging current, at the Instant when the Ckt is switch on, frequency of discharge. [8]
b) Explain photochemical machining. [8]

P.T.O.

Unit - III

- Q5)** a) What is ring rolling operation? Classify them and state their advantages and limitations. [9]
b) Explain in brief the process consideration in Isothermal forging for the processing of a shaft? [9]

OR

- Q6)** a) Compare orbital forging with radial forging. [9]
b) Explain the concept of powder forging? Write its advantages, limitations and applications. [9]

SECTION - II

Unit - IV

- Q7)** a) Explain with neat sketch continuous casting process. [8]
b) Explain with neat sketch a reciprocating mould process. [8]

OR

- Q8)** a) Explain suitable process for casting of brass. [8]
b) State and explain controlling parameters in injection casting process? [8]

Unit - V

- Q9)** a) Explain with neat sketch transfer moulding for plastic component. [8]
b) Explain different methods for plastic printing. [8]

OR

- Q10)** a) Explain with neat sketch for process of ceramic parts. [8]
b) Suggest and explain a suitable process for following [8]
i) Bucket,
ii) Dish.

Unit - VI

- Q11)** a) Explain factor consideration for surface cleaning and coating. [9]
b) Explain steps in MEMS. [9]

OR

- Q12)** Write notes on following : [18]
a) Ceramic coating,
b) Electro plating,
c) LIGA.



Total No. of Questions : 12]

SEAT No. :

P1201

[Total No. of Pages : 2

[4164] - 65

B.E. (Production Engg.)

ADVANCED PRODUCTION TECHNOLOGY

(Elective - II) (2003 Pattern) (Sem. - II)

Time :3 Hours]

[Max. Marks :100

Instructions to the candidates:-

- 1) *Answer three questions from section I and section II.*
- 2) *Answer to the two sections should be written in separate books.*
- 3) *Neat diagrams must be drawn wherever necessary.*

SECTION - I

Unit - I

- Q1)** a) Explain the basic frame work of TPS. [8]
b) Explain the features of Toyota Production system. [8]

OR

- Q2)** a) Explain how to shorten the lead times in TPS. [8]
b) Illustrate a JIT system with the help of neat block diagram. [8]

Unit - II

- Q3)** a) Explain the importance of benchmarking in manufacturing system. [8]
b) What is Business process reengineering? Compare it with reverse engineering. [9]

OR

- Q4)** a) What is mean by bottlenecks in operation? Explain how to identified and its effect on production. [9]
b) Explain the different ways to measure performance of manufacturing system. [8]

Unit - III

- Q5)** a) Explain performance objective productivity concept. [8]
b) Explain with suitable example the productivity measurement in a small industry. [9]

P.T.O.

OR

- Q6)** a) Describe the various factors for productivity improvement in medium scale industries. [9]
b) What is MBO? Explain steps in MBO. [8]

SECTION - II

Unit - IV

- Q7)** a) Explain simulation methodology applicable to manufacturing? [9]
b) Explain AI knowledge based expert system. [8]

OR

- Q8)** a) What is Artificial Intelligence? Explain rules in it. [8]
b) Explain to create a logical rule for decision making in AI? [9]

Unit - V

- Q9)** a) Explain methodology for system design in engineering? [8]
b) Explain the concept of design based on characteristics attributes. [8]

OR

- Q10)** Explain in brief the characteristics matrix with a suitable example. [16]

Unit - VI

- Q11)** a) Explain the term technology and important characteristics of technology management. [9]
b) Explain the role of government in technology development. [8]

OR

- Q12)** a) Explain the impact of technology on society and business. [9]
b) Explain the concept of technology diffusion. [8]



Total No. of Questions : 12]

SEAT No. :

P1202

[Total No. of Pages : 3

[4164] - 67

B.E. (Production Sandwich)
MECHATRONICS & ROBOTICS
(2003 Pattern) (Sem. I)

Time :3 Hours]

[Max. Marks :100

Instructions to the candidates:-

- 1) *Answers to the two sections should be written in separate books.*
- 2) *Answer three questions from each section.*
- 3) *Neat diagrams must be drawn wherever necessary.*
- 4) *Assume suitable data if necessary.*

SECTION - I

- Q1)** a) With a help of neat block diagram; differentiate clearly between closed loop control system and open loop control system. State advantages and limitations of each. [9]
- b) Discuss the functioning of an Engine Management System and draw a block diagram representing the basic elements of the control system for it. [9]

OR

- Q2)** a) State and explain the signal conditioning processes. [6]
- b) Discuss the following with neat sketches : [12]
- i) Inverting amplifier.
 - ii) Summing amplifier.
 - iii) Integrating amplifier.

- Q3)** Explain the following for a Microprocessor : [16]
- a) Assembler
 - b) Memory address.
 - c) Bus
 - d) Instruction Pointer.

OR

P.T.O.

- Q4)** a) Define [12]
i) TTL
ii) CMOS
iii) Digital Logic.
iv) Parity method for Error Detection
b) How does a microcontroller differ from microprocessor? [4]

- Q5)** a) What is an Instruction set? State and explain any four commonly used instructions that may be given to a microprocessor. [7]
b) Write a program in assembly language to determine the maximum Temperature obtained from a list of measured temperatures. [9]

OR

- Q6)** Explain the following with neat figures : [16]
a) Bidirectional Buffer.
b) Handshaking.
c) Polling and interrupts.
d) Serial interfacing.

SECTION - II

- Q7)** a) Explain the following, with the help of a ladder diagram. [8]
i) Latching.
ii) Sequencing.
b) Explain any two of the following : [8]
i) Rotary Encoder.
ii) Seebeck Effect
iii) Potentiometers.
iv) Pneumatic Proximity Sensor.

OR

- Q8)** a) Draw a ladder diagram for switching ON a motor on pressing a Green switch and switching OFF after 10 seconds of pressing the Red switch. [8]
b) State and explain a sensor to measure the following : [8]
i) Fluid Pressure.
ii) Liquid Flow.
iii) Temperature.
iv) Displacement.

Q9) Compare Pneumatic, Hydraulic and Electrical drives for robotic applications. State the particular applications of each in Robots. [16]

OR

Q10) State and explain various types of : [16]

- a) Valve bodies and Plugs.
- b) Ball and roller bearings.
- c) Solid state devices.

Q11) a) Define 'Robot' and explain clearly the operational features of industrial robots which make them different from fixed automation. [9]

b) With the help of a neat diagram, explain the basic components of a typical robotic system. [9]

OR

Q12) Explain the following terms : [18]

- a) Work envelope.
- b) Spatial Resolution.
- c) Degrees of freedom.
- d) Roll, pitch, yaw.
- e) Compliance.
- f) Repeatability.



Total No. of Questions : 12]

SEAT No. :

P1203

[Total No. of Pages : 2

[4164] - 68

B.E. (Production / Prod. S/W)

ERGONOMICS AND HUMAN FACTORS IN ENGINEERING

(Sem. - I) (2003 Pattern) (Elective - I)

Time :3 Hours]

[Max. Marks :100

Instructions to the candidates:-

- 1) *Answer any three questions from each section.*
- 2) *Answers to the two sections should be written in separate answer books.*
- 3) *Neat diagrams must be drawn wherever necessary.*
- 4) *Figures to the right indicate full marks.*
- 5) *Assume suitable data, if necessary.*

SECTION - I

- Q1)** a) Write a note on Luminance Ratio. [6]
b) What are Human Machine systems? Explain its types and characteristics. [12]

OR

- Q2)** a) What is ergonomics and what are the doctrines. [6]
b) Explain Work & Rest cycle. [6]
c) What are the various study areas of ergonomics. [6]

- Q3)** a) Explain static and dynamic dimensions. [8]
b) Explain the considerations in designing a seated workplace. [8]

OR

- Q4)** a) Explain various anthropometric dimensions required for designing of an umbrella. [8]
b) What are the requirements for designing safe product? [8]

- Q5)** a) Explain the principles of arranging components. [8]
b) Explain the Multifunction Hand Controls. [8]

OR

P.T.O.

- Q6)** Write short note on (any TWO). **[16]**
- a) Hand tool design.
 - b) Functions of controls.
 - c) Concept of visibility.
 - d) Location of controls in work place.

SECTION - II

- Q7)** a) Explain the effect of Noise on human performance. **[9]**
b) Differentiate between Discomfort glare & Disability glare. **[9]**

OR

- Q8)** a) What are the effects of excessive noise levels. What are the techniques of noise reduction. **[9]**
b) Explain the physiological effects of heat & cold. Explain its remedies. **[9]**

- Q9)** a) Discuss the effect of lighting on elderly? Also elaborate on Lighting for VDTs. **[12]**
b) Explain the significance of warnings in brief. **[4]**

OR

- Q10)** a) Explain the requirements for designing a safe product. **[8]**
b) Explain photometry in detail. **[8]**

- Q11)** a) Explain MOST and its types in brief. **[8]**
b) Explain the Mento Factor System in brief. **[8]**

OR

- Q12)** a) Differentiate between MTM1, MTM2 and MTM3 **[10]**
b) Explain the concept of Therbligs. **[6]**



Total No. of Questions : 12]

SEAT No. :

P1204

[Total No. of Pages : 2

[4164] - 71

B.E. (Production / Prod. S/W)

ADVANCED PRODUCTION TECHNOLOGY

(Elective - I) (2003 Pattern) (Sem. - I)

Time :3 Hours]

[Max. Marks :100

Instructions to the candidates:

- 1) *Answer three questions from each section.*
- 2) *Answers to the two sections should be written in separate books.*
- 3) *Neat diagrams must be drawn wherever necessary.*
- 4) *Assume suitable data if necessary.*

SECTION - I

Q1) State the principles of 'Toyota production system'. Explain the role of suppliers in TPS. **[18]**

OR

- Q2)** a) What is the KANBAN system? State and explain its types. What factors determine the quantity of Cards in each bin? **[8]**
- b) Discuss the following in TPS : **[10]**
- i) Seven types of Wastes.
 - ii) Root problem Solving.

Q3) Define 'Benchmarking Process'. Explain the step by step approach to Benchmarking. Discuss its Benefits and Uses. **[16]**

OR

- Q4)** Explain (any two) : **[16]**
- a) Bottlenecks.
 - b) Agile Manufacturing.
 - c) Green Manufacturing.

- Q5)** Explain : **[16]**
- a) Labour Productivity.
 - b) Multifactor Productivity.

OR

P.T.O.

- Q6)** a) State the objectives of Productivity Management. Discuss the Sources of Productivity Growth. [10]
b) Discuss the steps of productivity improvement. [6]

SECTION - II

- Q7)** a) Explain the process interaction approach in Simulation. [9]
b) What are the various types of Simulations? Explain. [9]

OR

- Q8)** Explain the following for Artificial Intelligence : [18]
a) Knowledge Representation.
b) Planning.
c) Natural Language Processing.

- Q9)** a) What is feasibility analysis? [16]
b) Why is it carried out?
c) Discuss its advantages.
d) State an example.

OR

- Q10)** Explain the concept of Product Design based on : [16]
a) Surface Topology.
b) Dimensional Tolerance.
c) Customer References.

- Q11)** a) What do you mean by Technology? Discuss its levels of development. [8]
b) State the different factors for surviving the industry in today's globalization era. [8]

OR

- Q12)** a) Compare Technology management with other managements. [8]
b) Explain the effect of change in technology in recent manufacturing trends. [8]



Total No. of Questions : 12]

SEAT No. :

P1206

[Total No. of Pages : 2

[4164] - 81

B.E. (Electrical Engineering)

POWER SYSTEM OPERATION & CONTROL

(2003 Pattern) (Sem. - I)

Time :3 Hours]

[Max. Marks :100

Instructions to the candidates:-

- 1) *Answer any three questions from each section.*
- 2) *Answers to the two sections should be written in separate books.*
- 3) *Neat diagrams must be drawn wherever necessary.*
- 4) *Figures to the right indicate full marks.*
- 5) *Use of electronic pocket calculator and is allowed.*

SECTION - I

- Q1)** a) State and derive the swing equation. [8]
b) Explain steady state stability and transient stability. State the assumption for transient stability analysis. [8]

OR

- Q2)** a) Explain the equal area criterion of stability for sudden short circuit on one of the parallel lines away from line ends (in the middle of a line). Derive the expression for critical clearing angle. [8]
b) Explain following terms [8]
i) Critical Clearing Angle.
ii) Critical Clearing Time.

- Q3)** a) What is unit commitment? Explain the objective function and various equality and inequality constraints used for unit commitment of thermal generating units. [8]
b) Explain with example, the 'priority list' method of unit commitment. [8]

OR

- Q4)** a) Explain with mathematical formulation, the dynamic programming method for unit commitment. [8]
b) Write short note on following [8]
i) Spinning reserve.
ii) Must run time.
iii) Shut down cost
iv) Start up cost.

P.T.O.

- Q5)** a) Explain the concept of 'Automatic Generation Control'. Explain with neat block diagram, the proportional plus integral load frequency control of an isolated power system. [10]
b) Write short note on [8]
i) Speed governor dead band.
ii) Generator rate constraint.

OR

- Q6)** a) With neat block diagram explain two area load frequency control. Explain the concept of Area Control Error (ACE). [12]
b) Explain digital load frequency controller. [6]

SECTION - II

- Q7)** a) Explain the centralized and decentralized control with reference to energy control center. [8]
b) Explain real time monitoring with functional block diagram. [8]

OR

- Q8)** Write short note on following. [16]
a) Data logging unit.
b) Man - machine interface.
c) Remote terminal unit.
d) Tele - metering.

- Q9)** a) Discuss FACTS controllers used for reactive power control [10]
b) Explain the steady state performance of static V Ar compensation. [8]

OR

- Q10)** a) Draw a typical loading capability curve of a generator. Explain the effect of variation of reactive power on the operation of synchronous generator. [10]
b) Explain the concept of compensation of line. [8]

- Q11)** a) Explain the concept of following : [8]
i) Energy banking.
ii) Power pools.
b) Discuss various advantages of interconnected power system. [8]

OR

- Q12)** Explain : [16]
a) Economy interchange evaluation.
b) Interchange evaluation with unit commitment.
c) Capacity and diversity interchange.



Total No. of Questions : 12]

SEAT No. :

P1207

[Total No. of Pages : 2

[4164] - 82

B.E. (Electrical)

UTILIZATION OF ELECTRICAL ENERGY

(2003 Pattern) (Sem. - I)

Time :3 Hours]

[Max. Marks :100

Instructions to the candidates:

- 1) *Answer 3 questions from Section - I and 3 questions from Section - II.*
- 2) *Answers to the two sections should be written in separate books.*
- 3) *Neat diagrams must be drawn wherever necessary.*
- 4) *Figures to the right indicate full marks.*
- 5) *Use of logarithmic tables slide rule, Mollier charts, electronic pocket calculator and steam tables is allowed.*
- 6) *Assume suitable data, if necessary.*

SECTION - I

- Q1)** a) State advantages of electrical heating. [6]
b) With a neat diagram explain core type induction furnace [6]
c) With a suitable diagram explain ultrasonic welding. [6]

OR

- Q2)** a) With a neat diagram explain the working of direct arc furnace. Draw equivalent circuit of arc furnace. [6]
b) A resistance oven uses nichrome wire as heating element which operates on single phase, 220 volt supply with a power rating of 16kW. If temperature of the element is to be limited to 1170°C and average temperature of charge is 500°C, find diameter and length of wire. Take radiating efficiency = 0.57, emissivity = 0.9, resistivity of nichrome = $109 \times 10^{-6} \Omega \text{ cm}$ [6]
c) Explain dielectric heating with a suitable diagram. State applications of dielectric heating. [6]

- Q3)** a) Explain briefly electroextraction of metals. [8]
b) With a suitable diagram explain working of water cooler. [8]

OR

P.T.O.

- Q4)** a) State the principle of anodizing. State the applications of anodising. [8]
b) Draw electric circuit of refrigerator and explain its working [8]

- Q5)** a) With a neat diagram explain working of incandescent lamp. [8]
b) State and elaborate the laws of illumination. [8]

OR

- Q6)** a) With a neat diagram explain working of sodium vapour lamp. [8]
b) Write a short note on LED. [8]

SECTION - II

- Q7)** a) State the advantages of electric traction. [10]
b) Explain kando system of track electrification. [8]

OR

- Q8)** a) Explain different current collection systems used in traction. [10]
b) Draw a block diagram of electric locomotive and explain it in brief. [8]

- Q9)** a) What is meant by tractive effort? Write the expression for total tractive effort and explain the terms involved in it. [8]
b) The speed - time curve of train consists of :
i) Uniform acceleration of 6kmphs for 21 sec.
ii) Free running time for 10 minutes.
iii) Uniform retardation of 6kmphs for stopping the train
iv) A stop of 5 minute
Calculate distance between the stations, average speed, schedule speed. [8]

OR

- Q10)** a) Explain the suitability of DC series motor for traction work. [8]
b) Explain regenerative braking for DC series motor. [8]

- Q11)** a) Explain series - parallel transition process with suitable diagram. [8]
b) Give electrical and mechanical characteristics of traction motors. [8]

OR

- Q12)** a) With a suitable diagram explain train lighting system. [8]
b) Compare shunt transition with bridge transition. [8]



Total No. of Questions : 11]

SEAT No. :

P1208

[Total No. of Pages : 3

[4164] - 83
B.E. (Electrical)
INDUSTRIAL DRIVES & CONTROL
(2003 Pattern) (Sem. - I)

Time :3 Hours]

[Max. Marks :100

Instructions to the candidates:

- 1) *Answer 3 questions from section - I and 3 questions from section - II.*
- 2) *Answers to the two sections should be written in separate books.*
- 3) *Neat diagrams must be drawn wherever necessary.*
- 4) *Use of logarithmic tables slide rule, Mollier charts, electronic pocket calculator and steam tables is allowed.*

SECTION - I

Q1) a) What are advantages of Electric drive? Explain main components used in drive. [8]

b) What are different torque components? Explain with their characteristics. [8]

OR

Q2) a) What is load equalization? What are reasons for using load equalization. [8]

b) A drive has following equations for motor and load torques :

$$T = (1 + 2w_m) \quad \text{and} \quad T_1 = 3\sqrt{wm}$$

Obtain the equilibrium points and determine their steady state stability. [8]

Q3) a) Explain advantages of electrical breaking. Explain different methods used for breaking. [8]

b) A 230V, 870 rpm and 100 A d.c. separately excited motor has an armature resistance of 0.05 Ω . It is coupled to an overhauling load with a torque of 400 N-m. Determine the speed at which motor can hold the load by regenerative breaking. [8]

OR

Q4) a) Explain dc dynamic breaking applied to 3 phase Induction motor. Draw speed torque characteristic. [8]

b) Explain plugging of dc motor along with speed torque characteristics. [8]

P.T.O.

- Q5)** a) Draw circuit diagram of 1 phase fully controlled converter fed dc shunt motor drive. Draw switching pulses, output voltage and current waveform. [10]
- b) A 200 V, 875 rpm, 150 A separately excited dc motor is fed from a single phase fully controlled rectifier with an ac source voltage of 220 V, 50 Hz, $R_a = 0.06 \Omega$. Conduction assumed to be continuous. Calculate firing angles for [8]
- i) rated motor torque and 750 rpm
- ii) rated motor torque and -500 rpm.

OR

- Q6)** a) Explain with neat circuit diagram chopper control dc series motor. Draw output voltage and current waveforms. [10]
- b) Explain dual control fed dc motor speed control. [8]

SECTION - II

- Q7)** a) State stator voltage speed control method of 3 phase Induction motor. Explain draw backs associated with it. [8]
- b) A 2.8 kW, 400 V, 50 Hz, 4 pole, 1370 rpm 3 phase delta connected squirrel cage induction motor has the following parameters $R_s = 2 \Omega$, $R_r' = 5 \Omega$, $X_s = X_r' = 5 \Omega$, $X_m = 80 \Omega$. Motor speed is controlled by stator voltage control. When driving a fan load it runs at rated speed at rated voltage. Calculate. [8]
- i) Motor terminal voltage, current and torque at 1200 rpm.
- ii) Motor speed, current and torque at terminal voltage of 300 V.

OR

- Q8)** a) Explain variable frequency control used for 3 phase induction motor. Draw VSI fed Induction motor drive. [8]
- b) What are different methods for voltage and frequency control of 3 phase Induction motor. [8]
- Q9)** a) What are different measures to be carried out for energy conservation of electric drives. [8]
- b) With one application each explain different classes of motor duty. [8]

OR

- Q10)** a) What are factors for determining motor ratings? [8]
b) Explain thermal model of drive. Draw heating cooling curve and explain from that how temperature rise is calculated. [8]

Q11) Write short notes on any three: [18]

- a) Drives used in paper mill.
- b) Servo drives.
- c) Drives used in Rolling mills.
- d) Drives used in machine tool application
- e) Stepper motor drives.



Total No. of Questions : 12]

SEAT No. :

P1209

[Total No. of Pages : 3

[4164] - 84
B.E. (Electrical)
CONTROL SYSTEM - II
(2003 Pattern) (Sem. - I)

Time : 3 Hours]

[Max. Marks : 100

Instructions to the candidates:-

- 1) *Answer 3 questions from Section - I and 3 questions from Section - II.*
- 2) *Answers to the two sections should be written in separate books.*
- 3) *Neat diagrams must be drawn wherever necessary.*
- 4) *Use of logarithmic tables slide rule, Mollier charts, electronic pocket calculator and steam tables is allowed.*

SECTION - I

- Q1)** a) Explain advantages of state variable method over conventional one. [5]
b) Convert the T.F. into state space form. [6]

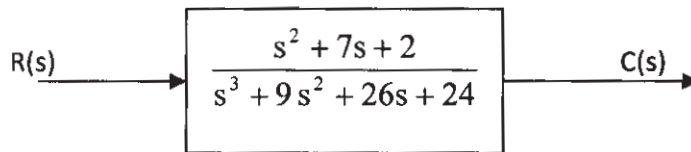

- c) Elaborate upon the basis of selecting suitable state variables for a system. [5]

OR

- Q2)** a) Find the T.F. [8]

$$\dot{X} = \begin{bmatrix} -4 & -1.5 \\ 4 & 0 \end{bmatrix} X + \begin{bmatrix} 2 \\ 0 \end{bmatrix} u(t)$$

- b) Derive two state models for the system with transfer function. [8]
i) One for which the system matrix is a companion matrix.
ii) One for which the system matrix is diagonal

$$\frac{Y(s)}{U(s)} = \frac{50(1 + s/5)}{s(1 + s/2)(1 + s/50)}$$

- Q3)** a) Explain the various methods of finding state transition matrix. [8]

P.T.O.

b) Using Laplace transform method find the matrix exponential e^{At} for [8]

i) $A = \begin{bmatrix} 0 & -3 \\ 1 & -4 \end{bmatrix}$

ii) $A = \begin{bmatrix} 0 & 1 \\ -3 & -4 \end{bmatrix}$

OR

Q4) a) Explain how to find solution of homogeneous equation from state transition matrix. [8]

b) Obtain the time response of the following system. [8]

$$\dot{X}(t) = \begin{bmatrix} 1 & 0 \\ 1 & 1 \end{bmatrix} \begin{bmatrix} x_1 \\ x_2 \end{bmatrix} + \begin{bmatrix} 1 \\ 1 \end{bmatrix} u$$

$$u(t) = 1 \text{ at } t = 0, X^T(0) = [1 \ 0]$$

$$A = \begin{bmatrix} 1 & 0 \\ 1 & 1 \end{bmatrix}, B = \begin{bmatrix} 1 \\ 1 \end{bmatrix}$$

Q5) a) Define Controllability. Explain methods to determine controllability. [10]

b) The following model realize the transfer function. [8]

$$G(s) = \frac{1}{s+1}$$

$$A = \begin{bmatrix} -2 & 1 \\ 1 & -2 \end{bmatrix}; B = \begin{bmatrix} 1 \\ 1 \end{bmatrix}; C = [0 \ 1]$$

Investigate the controllability and observability properties of these models.

OR

Q6) a) State effect of pole zero cancellation on controllability and observability. [8]

b) Consider the system defined by [10]

$$\dot{x} = Ax + Bu$$

$$\text{where } A = \begin{bmatrix} 0 & 1 & 0 \\ 0 & 0 & 1 \\ -1 & -5 & -6 \end{bmatrix}, B = \begin{bmatrix} 0 \\ 0 \\ 1 \end{bmatrix}$$

By using the state feedback control $u = -kx$ it is desired to have the closed loop poles at $s = -2 + j4$, $s = -2 - j4$ and $s = -10$. Determine the state feedback gain matrix K .

SECTION - II

- Q7)** a) Derive describing function of saturation with dead zone. [8]
 b) Explain different peculiar characteristics of nonlinear system. [8]

OR

- Q8)** a) Explain phenomenon exhibited by nonlinear system subharmonic oscillation, asynchronous quenching, frequency entrainment. [8]
 b) Explain how stability is determined by describing function method. [8]

- Q9)** a) Define and classify different singular points. [8]
 b) A linear second order servo is described by eqn. [8]

$$\ddot{y} + 2\xi\omega_n \dot{y} + \omega_n^2 y = \omega_n^2 \text{ for } \omega_n = 1$$

find singular points when $\xi = 0, 0.15$

OR

- Q10)** a) With reference to Liapunov's stability explain asymptotic stability, instability, positive definiteness, negative definiteness. [8]
 b) Compare D.F. method of stability analysis with phase plane method. Explain isoclines method of constructing phase trajectory. [8]

- Q11)** a) Explain different performance index terms like ISE, ITAE, IAE & ITSE. [6]
 b) Explain mathematical procedure for optimal control design. [6]
 c) Explain factors for designing optimal controller. [6]

OR

- Q12)** Write short note on : [18]
 a) Electric, and pneumatic actuators.
 b) Lever, gear, clutch, brakes.
 c) Relays and sensors.



Total No. of Questions : 12]

SEAT No. :

P1210

[Total No. of Pages : 2

[4164] - 85

B.E. (Electrical)

ROBOTICS AND AUTOMATION

(Elective - I) (2003 Pattern) (Sem. - I)

Time :3 Hours]

[Max. Marks :100

Instructions to the candidates:

- 1) Answers to the two sections should be written in separate books.
- 2) Neat diagrams must be drawn wherever necessary.
- 3) Figures to the right indicate full marks.
- 4) Assume suitable data, if necessary.

SECTION - I

- Q1)** a) Explain basic concept of Automation. [6]
b) Compare Automated machines with robot. [6]
c) Give historical development of robot. [6]

OR

- Q2)** a) Explain different types of automation. [6]
b) Define Accuracy, repeatability and compliance with neat sketch. [6]
c) Explain Arm prostheses in detail with neat sketch. [6]

- Q3)** a) Explain continuous path manipulator and point to point motion of a manipulator. [8]
b) Explain Robot classification according to co-ordinate system. [8]

OR

- Q4)** a) Explain different types of joints and End - Effectors. [8]
b) Draw and explain cylindrical robot compare its work envelop with cartesian robot. [8]

OR

- Q5)** a) Two points $A = [4 \ 3 \ 2]^T$ and $B = [4 \ 2 \ 6]^T$ are to be translated a distance +3 units along x - axis and - 2 units along z - axis. Use Homogeneous transformation to find final points A_f & B_f [8]
b) Explain in detail rotational transformation. [8]

OR

P.T.O.

- Q6)** a) Explain Translational Transformation with neat sketch. [8]
b) Write short note on singularities in Eulers angles. [8]

SECTION - II

- Q7)** a) Explain spray painting robot in detail. [10]
b) Write short notes on on-line and off-line programming. [8]

OR

- Q8)** a) Explain robot application in case of welding. [10]
b) Classify robot specific languages. [8]

- Q9)** a) Explain D - 4 representation of a kinematic chain. [8]
b) What is the geographic approach in inverse kinematic [8]

OR

- Q10)** a) Explain in detail rules for link co - ordinate frame of kinematic chain. [8]
b) Differentiate Inverse kinematic & Farward kinematic. [8]

- Q11)** a) Explain RMRC with the help of neat sketch. [8]
b) Explain Lagrengian analysis for dynamical equation. [8]

OR

- Q12)** a) Explain RMPC with the help of neat sketch. [8]
b) Explain JPC with the help of neat sketch. [8]



Total No. of Questions : 12]

SEAT No. :

P1211

[Total No. of Pages : 3

[4164] - 86

B.E. (Electrical)

POWER QUALITY

(2003 Pattern) (Elective - I) (Sem. - I)

Time :3 Hours]

[Max. Marks :100

Instructions to the candidates:-

- 1) *In Section I, attempt Q 1 or Q2, Q3 or Q4, Q5 or Q6. In Section II, attempt Q 7 or Q 8, Q9 or Q10, Q11 or Q12.*
- 2) *Answer to the two sections should be written in separate answer books.*
- 3) *Figures to the right indicate full marks.*
- 4) *Neat diagrams must be drawn wherever necessary.*
- 5) *Use of non - programmable electronic pocket calculator is allowed.*
- 6) *Assume suitable data, if necessary.*

SECTION - I

- Q1)** a) Define and explain the following terms as per IEEE Std. 1159, such as [10]
- i) Long duration voltage variations
 - ii) Voltage swells.
 - iii) Voltage flicker
 - iv) Voltage sags and
 - v) Transients.
- b) What are the objectives of grounding? What are the problems due to poor grounding? [8]

OR

- Q2)** a) Define with graphical representation various RMS voltage variations as per IEEE std. 1159 - 1995. [10]
- b) Explain various definitions of power quality with reference to each stake holders. [8]
- Q3)** a) Explain impact of reactive power management on voltage profile. What are the causes of undervoltages? [8]
- b) What are the various causes of voltage flicker and explain their effects on power system operation. [8]

OR

P.T.O.

- Q4)** a) Explain RMS voltage variation and complex power concept in the power systems. [8]
b) Explain the following terms related with voltage flicker
i) Short term (P_{st}) and
ii) Long term (P_{lt}) voltage flicker. [8]

- Q5)** a) Explain step by step procedure for assessment of equipments sensitivity to voltage sags. [8]
b) Explain economic impact of voltage sag and its consequences. [8]

OR

- Q6)** a) Explain influence of fault location and fault level on voltage sags. [8]
b) What are the mitigation measures for voltage sags? Explain any two measures in detail. [8]

SECTION - II

- Q7)** a) Explain in detail stepwise procedure of IEEE 519-1992 for harmonic analysis. [10]
b) Explain the following terms related with waveform distortion [8]
i) Harmonics.
ii) Interharmonics
iii) Subharmonics.
iv) Tripln harmonics.

OR

- Q8)** a) What is harmonic filtering? Explain active and passive filters. [8]
b) What are harmonic resonances? Explain consequences of harmonic resonances [10]

- Q9)** a) Explain transients, their sources and its effects on power system operation. [8]
b) List various devices used for over voltage protection? Describe any two in detail. [8]

OR

- Q10)** a) Explain switching transient problems with loads. Which computer tools are used for transient's analysis? [10]
b) Explain capacitor switching transient and magnification of capacitor switching transient. [6]

- Q11)** a) Explain need of power quality monitoring. What are the different approaches followed in power quality monitoring? [8]
b) Explain selection procedure of transducers for power quality monitoring. [8]

OR

- Q12)** a) What are the requirements of power quality monitor to monitor various power quality parameters and various techniques of data collection? [8]
b) Explain various equipments which are used for monitoring power quality. [8]



Total No. of Questions : 12]

SEAT No. :

P1212

[Total No. of Pages : 2

[4164] - 88

B.E. (Electrical Engineering)

PROJECT MANAGEMENT

(2003 Pattern) (Elective - I) (Theory) (Sem. - I)

Time :3 Hours]

[Max. Marks :100

Instructions to the candidates:

- 1) *Answers of section - I and section - II should be written on separate answer sheets.*
- 2) *Figures to the right indicate maximum marks for the respective question.*
- 3) *Use of scientific calculator is allowed.*

SECTION - I

- Q1)** a) Describe various phases of 'Project Life Cycle'. [8]
b) What parameters are used to appraise a project? Explain. [8]

OR

- Q2)** a) Explain the important characteristics of 'Project Management'. [8]
b) Describe various types of project organisations. [8]

- Q3)** What are the different costs associated with 'projects'? Explain. How are they estimated? [16]

OR

- Q4)** Explain various techniques used in project costs controlling. What are probable causes of project failures? Illustrate with suitable examples. [16]

- Q5)** Write short notes on, [18]
a) Gantt chart and its applications.
b) PERT
c) CPM

OR

- Q6)** Write short notes on : [18]
a) AOA & AON.
b) GERT
c) Resource Allocation.

P.T.O.

SECTION - II

Q7) Explain the factors responsible for cost escalation. Describe accounting systems used for project costs. **[16]**

OR

Q8) Enumerate elements of budget. Explain the process of budgetary control. **[16]**

Q9) Write short notes on :

a) Processes of project quality management. **[8]**

b) Techniques of quality assurance and control. **[8]**

OR

Q10) Describe the need for quality planning and explain how to assure quality of procured items. **[16]**

Q11) a) The analyst forecasts five distinct states of economy. He further estimates the probability of occurrence of each and also the likely return on investment as shown below :

State of Economy	Probability of occurrence	ROI
Strong boom	0.20	35%
Mild boom	0.15	20%
Average Economy	0.30	15%
Mild recession	0.15	10%
Strong recession	0.20	5%

Find the expected rate of return based on the above information. **[6]**

b) Write short notes on :

i) CAPM **[6]**

ii) Adjusted discount rate method. **[6]**

OR

Q12) Write short notes on :

a) Certainty Equivalent method. **[6]**

b) Correlation Coefficient. **[6]**

c) Portfolio risks. **[6]**



Total No. of Questions : 12]

SEAT No. :

P1229

[Total No. of Pages : 3

[4164] - 113
B.E. (Electronics)
REAL TIME OPERATING SYSTEMS
(Elective - II) (2003 Pattern) (Sem. - II)

Time :3 Hours]

[Max. Marks :100

Instructions to the candidates:-

- 1) *Answers to the two sections should be written in separate answer books.*
- 2) *In section - I attempt Q.1 or 2, Q.3 or 4 and Q.5 or 6. In section - II attempt Q.7 or 8, Q.9 or 10 and Q.11 or 12.*
- 3) *Neat diagrams, flow charts must be drawn and well commented pseudo code written wherever necessary.*
- 4) *Figures to the right indicate full marks.*
- 5) *Assume suitable data, if necessary.*

SECTION - I

- Q1)** a) What is context switching? Give suitable example. [6]
b) How priorities are assigned to the task in multitasking system? [4]
c) Explain how interrupts are responding in systems. Define interrupt latency interrupt response and interrupt recovery. [6]

OR

- Q2)** a) What is critical section? Give suitable example. [6]
b) Compare preemptive and non preemptive kernel. Explore the application of both. [4]
c) What is dead lock? Give suitable example. [6]

- Q3)** a) What are the data structures and variables used to handle priority of task for scheduling? [6]
b) What is statistic task? How it is initialized. [6]
c) What is event in uCOSII. Explain ECB data structure? [6]

OR

- Q4)** a) Draw and explain state diagram of task. Show various conditions for transitions. [6]
b) Explain and describe TCB data structure in uCOSII [6]
c) How to set and query on system time? [6]

P.T.O.

- Q5)** a) Enlist different MUTEX services. What configuration constants provided to configure MUTEX? [6]
 b) Explain Event Flag Group data structure OS_FLAG_GRP and OS_FLAG_NODE. [6]
 c) What is relationship between Task, Mutex and ISR in uCOSII? [4]

OR

- Q6)** a) What is relationship between Task, ISR and Semaphore in uCOSII?[6]
 b) Write short note on any two [10]
 i) Semaphore management in uCOSII.
 ii) Mutual exclusion semaphore in uCOSII.
 iii) Event flag management in uCOSII.

SECTION - II

- Q7)** a) How to use Mailbox as binary semaphore. Explain by using pseudo code.[6]
 b) What is relationship between Task, ISR and Message Queue in uCOSII. [4]
 c) What are message queue services in uCOSII? How Message Queue services enabled/disabled in uCOSII. [6]

OR

- Q8)** a) What is relationship between tasks, ISR and Mailbox in uCOSII? [4]
 b) How to use Message Queue as counting semaphore,use pseudo code? [6]
 c) Explain Mailbox services and configuration in uCOSII. [6]

- Q9)** a) Explain uCOSII hardware and software architecture. [6]
 b) Explain memory control block in uCOSII. [6]
 c) Explain the system requirements for porting of uCOSII. [4]

OR

- Q10)** a) What is the need of memory management services by OS as compare to compiler function? [6]
 b) Explain memory management services provided in uCOSII. [4]
 c) What is memory partition and multiple memory partition, explain. [6]

- Q11)** Assume appropriate data wherever necessary and consider the design and implementation of 'Temperature Controller' by using uCOSII.
 a) Enlist the performance parameters, constraints and assign priorities to the defined tasks. [6]
 b) Enlist the API required to be used for implementation. [6]
 c) Write application code for the above system. [6]

OR

Q12) Assume appropriate data wherever necessary and consider the design and implementation of “Chocolate Vending Machine’ by using uCOSII.

- a) Enlist the performance parameters, constraints and assign priorities to the defined tasks. [6]
- b) Enlist the API required to be used for implementation. [6]
- c) Write application code for the above system. [6]



Total No. of Questions : 12]

SEAT No. :

P1230

[Total No. of Pages : 2

[4164] - 114

B.E. (Electronics)

ARTIFICIAL INTELLIGENCE

(2003 Pattern) (Elective - II) (Sem. - II)

Time :3 Hours]

[Max. Marks :100

Instructions to the candidates:-

- 1) *Answers to the two sections should be written in separate books.*
- 2) *Neat diagrams must be drawn wherever necessary.*
- 3) *Figures to the right indicate full marks.*

SECTION - I

Q1) a) What are the various heuristic search techniques used in AI? Explain A* algorithm. [10]

b) Explain means ends analysis. [6]

OR

Q2) a) Compare depth first search and breadth first search. [8]

b) State and explain various applications of AI. [8]

Q3) a) What are the challenges faced by minimax algorithm and how they overcome using Alpha beta pruning? [8]

b) What is horizon effect? How is it overcome? [8]

OR

Q4) a) Explain different approaches used for knowledge representation? What are the issues in knowledge representation? [8]

b) Explain concept of resolution? [8]

Q5) a) Construct a script for going to movie from view point of movie goer.[9]

b) How can we use frames to represent knowledge? Explain with a suitable examples. [9]

OR

P.T.O.

- Q6)** a) Explain Truth maintenance system with the help of an example. [9]
b) Write short notes on [9]
i) Semantic nets.
ii) Fuzzy logic.

SECTION - II

- Q7)** Write short notes on [18]
a) Hierarchical planning.
b) Least commitment approach.

OR

- Q8)** a) Write short notes on [12]
i) TWEAK
ii) STRIPS
b) Compare between linear planning and non linear planning. [6]

- Q9)** a) Explain how ANN can be used for pattern recognition? [8]
b) Explain Robot Architecture. [8]

OR

- Q10)** a) Explain how robots navigate through world and manipulate objects? [8]
b) State the detailed steps used in waltz algorithm for labelling. Give an example for which waltz algorithm would not find unique labelling? [8]

- Q11)** a) Explain the functioning of expert system with the help of an example?[8]
b) Explain the morphological and pragmatic analysis with respect to NLP.[8]

OR

- Q12)** a) Explain the steps involved in Natural Language processing? [8]
b) Explain how ATN and RTN can be used in NLP? [8]



Total No. of Questions : 12]

SEAT No. :

P1231

[Total No. of Pages : 2

[4164] - 115

B.E. (Electronics Engineering)
ROBOTICS & INDUSTRIAL AUTOMATION
(2003 Pattern) (Elective - II) (Sem. - II)

Time :3 Hours]

[Max. Marks :100

Instructions to the candidates:-

- 1) *Answers to the two sections should be written in separate answer books.*
- 2) *Neat diagrams must be drawn wherever necessary.*
- 3) *Figures to the right indicate full marks.*

SECTION - I

- Q1)** a) Explain how flexible automation is superior over fixed automation with respect to following points : **[10]**
- i) Reaction time.
 - ii) Debugging.
 - iii) Obsolescence.
 - iv) Cost.
 - v) Applications.
- b) Explain with neat diagram following components of Robot system : **[8]**
- i) Manipulator.
 - ii) Controller.
 - iii) Power conversion unit.

OR

- Q2)** a) With the help of figures, explain the Robot as a controller and Robot as a peripheral. **[10]**
- b) Write in brief about present trends and future trends in Robotics. **[8]**
- Q3)** a) Explain the term Hand Matrix. **[8]**
- b) Explain the Direct approach for getting inverse solution. **[8]**

OR

- Q4)** a) What do you mean by D-H representation? State D-H Algorithm. **[8]**
- b) Draw a neat diagram of wrist manipulator and explain yaw - pitch & Roll. **[8]**

P.T.O.

- Q5)** a) State different types of end effectors. Explain any one in detail. [8]
b) Explain the operation of Laser range finder. [8]

OR

- Q6)** a) What is the need of actuator in Robotic system? State its types. Explain any one. [8]
b) Write the working principle, draw the diagram and state applications of optical proximity sensor. [8]

SECTION - II

- Q7)** a) Define Trajectory of a Robot. State advantages and disadvantages of defining trajectory using work - space co - ordinates and joint - space coordinates. [10]
b) What is a Fuzzy system? Explain the role of fuzzy controller in Robot System. [8]

OR

- Q8)** a) Explain Jacobian in terms of D-H matrix. [10]
b) Explain different types of motions used in motion planning of Robot. [8]

- Q9)** a) State and explain the techniques used for object recognition in Robot Vision System. [8]
b) Explain different structured illumination techniques used in Robot Vision System. [8]

OR

- Q10)** a) With the help of neat block diagram explain the machine vision system in Robotics. [8]
b) Write a brief note on intelligent sensors. [8]

- Q11)** a) Describe the term “Nanorobots”. State its applications. [8]
b) Discuss the applications of robot for assembly in Industry. [8]

OR

- Q12)** a) Explain with neat Block diagrams [8]
i) MEMS as Microsensor.
ii) MEMS as Microactuator.
b) Write a brief note on “Role of Robotics in Automation”. [8]



Total No. of Questions : 12]

SEAT No. :

P1619

[Total No. of Pages : 2

[4164] - 152

B.E. (Instrumentation & Control)

ADVANCED BIOMEDICAL INSTRUMENTATION

(2003 Pattern) (Elective - II) (Sem. - II)

Time :3 Hours]

[Max. Marks :100

Instructions to the candidates:

- 1) *Answer 3 questions from section - I and 3 questions from section - II.*
- 2) *Answers to the two sections should be written in separate answer books.*
- 3) *Neat diagrams must be drawn wherever necessary.*

SECTION - I

- Q1)** a) List the types of fibrillation. [4]
b) List the types of electrodes used in defibrillation. [4]
c) What are classification of defibrillator? Explain any one of them? [8]

OR

- Q2)** a) Explain different modes of electrosurgical unit. Also, write down specifications of ESU. [10]
b) What are different electrode configuration used in cutting and coagulation mode. [6]

- Q3)** a) With the help of graph, explain the basic working principle of a pulse oximeter. [8]
b) Describe system components for a typical Telemedicine System. [10]

OR

- Q4)** a) Explain instrumentation in blood cell counting. [10]
b) List and explain various methods for glucose measurement. [8]

- Q5)** a) Explain the construction of X ray tube with the help of neat diagram.[6]
b) What is CT scanning? What are its advantages? [5]
c) What is the role of 'Hounsfield number' in image reconstruction? [5]

OR

- Q6)** a) What are the desirable properties of ultrasound. [8]
b) What is echoencephalograph? [8]

P.T.O.

SECTION - II

- Q7)** a) Explain with the help of a block diagram, the working of MRI instrumentation system? [8]
b) Draw the diagram of ultrasound scanner and explain its working. [8]

OR

- Q8)** a) What is Nuclear medicine? Describe various types of detectors that are used to detect β and γ rays. [8]
b) Describe various types of gantries used in CT scanner. [8]

- Q9)** a) Why to use various method of imaging and list them. [8]
b) Which properties of laser make them suitable for biomedical applications? Explain any one application of laser in Ophthalmology. [8]

OR

- Q10)** a) Explain the thermal effect of laser on body tissue and elaborate its application using this effect. [8]
b) What is Lithotripsy? Explain in detail 'shock wave Lithotripsy'. [8]

- Q11)** a) Describe various Orthotic and Prosthetic devices. [8]
b) State any three materials used for wheelchair and specify their properties. [10]

OR

- Q12)** a) List any four points of comparison of dialysis techniques. [8]
b) Describe with the help of neat diagram the principle of ultrasound lithotripsy. [10]



Total No. of Questions : 12]

SEAT No. :

P1620

[Total No. of Pages : 2

[4164] - 153

B.E. (Instrumentation & Control)
POWER PLANT INSTRUMENTATION
(2003 Pattern) (Elective - II) (Sem. - II)

Time :3 Hours]

[Max. Marks :100

Instructions to the candidates:-

- 1) *Answers to the two sections should be written in separate books.*
- 2) *Neat diagrams must be drawn wherever necessary.*
- 3) *Figures to the right indicate full marks.*
- 4) *Assume suitable data, if necessary.*
- 5) *All questions are compulsory.*

SECTION - I

- Q1)** a) What are various forms of energy? Enlist various sources used for obtaining the same. [8]
- b) Compare Hydroelectric Power generation with Thermal Power Generation. [8]

OR

- Q2)** a) Is Solar Energy is Non - Conventional energy? Explain Solar Energy generation as Natural Source of Energy generation. [8]
- b) What are Pulverized fuel fired water tube boilers? Explain same also show Air and Flue gas paths for it. [8]
- Q3)** a) Explain Combustion control method in detail with neat sketch. [9]
- b) Explain the operation of a continuous combustion, Constant Pressure gas turbine with the help of Suitable sketch. [9]

OR

- Q4)** a) Explain Fission & Fusion in Nuclear Power Plant with suitable examples. Also draw the neat sketch of Nuclear Reactor. [10]
- b) Propose the scheme for measurement of Feed water flow measurement. Justify the sensor used. [8]
- Q5)** a) What are the causes of Turbine Automatic run - up? How it is controlled? [8]
- b) "Water tube boilers are most widely used in modern power plants", Justify with suitable reasons. [8]

P.T.O.

OR

- Q6)** a) What are the advantages gained by using economizer in modern power plant? Discuss in brief. [8]
b) What are the six categories of Turbine Instrumentation? Explain supervisory Instrumentation in Detail. [8]

SECTION - II

- Q7)** a) What are the factors affecting selection of site for Hydroelectric Power plant? Explain principle of Hydroelectric Power generation. [8]
b) Explain the Need, and the Basic principle of Smoke Density measurement? [8]

OR

- Q8)** a) Explain Nuclear Instrumentation in Nuclear Power Plant? [8]
b) Discuss in detail the radioactivity and human safety in Atomic Power Plant. [8]
- Q9)** a) Explain Need, Principle & working of ESP used in Power Plant. [9]
b) Explain VFD's & their applications in Power generation station. [9]

OR

- Q10)** a) Explain the structure of DCS suitable for Power Plant with necessary building blocks. [12]
b) Discuss Boiler Regulation in brief. [6]
- Q11)** a) Explain the factors affecting the selection of site for setting up the Wind Energy Power Plant. [8]
b) Explain Tidal Power Generation along - with its advantages & limitations. [8]

OR

- Q12)** a) With the help of neat sketch explain different types of Collectors used in Solar Power generation. [6]
b) Write notes on [10]
i) Photovoltaic cells,
ii) Hydrogen cells.



Total No. of Questions : 6]

SEAT No. :

P1622

[Total No. of Pages : 2

[4164] - 163
B.E. (Printing)
OFFSET MACHINES - II
(2003 Pattern) (Sem. - I)

Time :3 Hours]

[Max. Marks :100

Instructions to the candidates:-

- 1) *All questions are compulsory.*
- 2) *Answers to two sections should be written in separate books.*

SECTION - I

- Q1)** Explain the following **[16]**
- a) Explain different types of reel stands.
 - b) Explain working of dancer roller and metering unit.

OR

- Explain the following **[16]**
- a) Purpose and design of a vertical press.
 - b) Y type cylinder arrangement and its use for newspaper
 - c) Reel design.
 - d) Problems during splicing.

- Q2)** a) How condition of rollers is checked and explain setting of rollers. **[8]**
- b) Explain ductless dampening used in web offset. **[8]**

OR

- a) Ink train in web offset. **[16]**
- b) Setting of ink in cold set web offset.
- c) Plate cylinder clamping in web offset machine.
- d) Cylinder Packing and pressure setting.

- Q3)** Explain the working of a combination dryer along with scavenger knife. **[18]**

OR

- a) Explain purpose of chilling in web offset. **[9]**
- b) List down various parts of ribbon folder and its significance **[9]**

P.T.O.

SECTION - II

Q4) What is web tension. What are the various means to control web tension.[18]

OR

Explain the effect of moisture in paper on web tension. Which section of press has more chances of web break in machine and why? [18]

Q5) Explain antistatic devices and refrigeration unit for dampening unit. [16]

OR

a) State checklist of maintenance of sensors used through the whole web press. [8]

b) What is total productive maintenance? Explain its importance w.r.t. web offset and newspaper production. [8]

Q6) Explain remedies for the following : [16]

a) Ink and water absorption in substrate.

b) Static in heat set.

c) Gear streaks.

d) Dot gain on press.

OR

Explain following paper problems : [16]

a) Bluish paper shade.

b) Web cuts.

c) Loose fibres on paper.

d) Web wandering.



Total No. of Questions : 6]

SEAT No. :

P1623

[Total No. of Pages : 2

[4164] - 170

B.E. (Printing)

SUBSTRATES & INK TECHNOLOGY

(2003 Pattern) (Sem. - II)

Time :3 Hours]

[Max. Marks :100

Instructions to the candidates:-

- 1) *Answer to the two sections should be written in separate books.*
- 2) *Neat diagrams must be drawn wherever necessary.*
- 3) *Figures to the right indicate full marks.*

SECTION - I

Q1) Answer any one **[18]**

- a) Write down the name of various machines used in paper manufacturing. Explain importance of Fourdriver machine.
- b) Write down various stages of paper manufacturing of. Explain effect of each process on surface properties of paper.

Q2) Answer any one **[16]**

- a) List and explain various optical properties of paper with their TAPPI measuring method.
- b) Explain effect of moisture on paper.

Q3) Write any one **[16]**

- a) Find out the total quantity of paper required in the size 55×90 cms for printing 10,000 booklets in the A4 size. Assume each booklet contains 48 pages.
- b) Write down various points required to consider for calculating costing of printing job consider all pre-press to post-press option.

SECTION - II

Q4) Answer any one **[18]**

- a) Explain organic & Inorganic pigments used for manufacturing of Printing Inks.
- b) Explain diff. types of resins used in Printing Inks.

P.T.O.

- Q5)** Solve any one. **[16]**
- a) Explain Ink rheology for web offset printing process.
 - b) Differentiate water based inks & solvent based inks used for Flexography printing process.

- Q6)** Write down any two **[16]**
- a) Importance of green printing.
 - b) Electrophotography ink formulation.
 - c) List & explain various waste management techniques.



Total No. of Questions : 8]

SEAT No. :

P1624

[Total No. of Pages : 2

[4164] - 210

B.E. (Petroleum)

OIL WELL DRILLING ENGINEERING

(2003 Pattern) (Sem. - II)

Time :3 Hours]

[Max. Marks :100

Instructions to the candidates:-

- 1) *Question Nos. 1 and 5 are compulsory. Out of the remaining attempt 2 questions from section I and 2 questions from section II.*
- 2) *Answers to the two sections should be written in separate books.*
- 3) *Neat diagrams must be drawn wherever necessary.*
- 4) *Figures to the right indicate full marks.*
- 5) *Use of logarithmic tables slide rule, Mollier charts, electronic pocket calculator and steam tables is allowed.*
- 6) *Assume suitable data, if necessary.*

SECTION - I

Q1) Discuss derrick and block tackle system calculate

- a) Static tension in the fast line when upward motion is impending
- b) Maximum hook horse power.
- c) Maximum hoisting speed.
- d) Actual derrick load.
- e) Max equivalent load.
- f) Derrick efficiency factor.

(Assume dead line near leg A, Draw works between leg C and D).

Data :

Hoisting load 300,000 lb, draw works provide an input power to block and tackle system is 500 hp, Eight line strung between the crown block and traveling block. Power efficiency = 0.841. [18]

Q2) a) Discuss IADC classification of bit, bit selection procedure in brief. [8]

b) Discuss depthwise optimization of rig - hydraulics. [8]

Q3) a) Discuss type one or L spape geometrical planning of directional well.[8]

b) Discuss minimum curvature method. [8]

P.T.O.

- Q4)** Write short note **[16]**
- a) GTO
 - b) Drill string design.
 - c) Type of wells.
 - d) Well bore stability

SECTION - II

- Q5)** a) Discuss casing seat depth selection procedure in detail. **[8]**
- b) Calculate cement slurry weight and water needed to mix a slurry consisting of class H, 35% sand, 0.5% retarder, 46% water. **[6]**

Data given :

Class H cement = 94 lb/sack.

absolute volume of class H cement = 3.60 gal/sack.

absolute volume of sand = 0.0456

Water weight = 8.33 ppg

Basis : 1 sack of class H cement.

- c) Discuss different API grades of casing. **[4]**
- Q6)** a) Draw BOP stack and discuss different types of ram preventers in detail. **[8]**
- b) Write different causes of well kick. **[4]**
- c) Compare driller's method and weight & wait method of well control. **[4]**

- Q7)** a) Discuss different offshore drilling rigs with suitable sketch. **[10]**
- b) Discuss step by step procedure of offshore drilling. **[6]**

- Q8)** Write short notes on **[16]**
- a) BOP stack function test.
 - b) Utility of SIDPP and SICP pressures.



Total No. of Questions : 8]

SEAT No. :

P1625

[Total No. of Pages : 2

[4164] - 213

B.E. (Petroleum Engg.)

DEEP WATER TECHNOLOGY

(2003 Pattern) (Elective - II) (Sem. - II)

Time :3 Hours]

[Max. Marks :100

Instructions to the candidates:-

- 1) Question Nos. 1 and 8 are compulsory. Out of the remaining attempt 2 questions from section I and 2 questions from section II.
- 2) Answers to the two sections should be written in separate books.
- 3) Neat diagrams must be drawn wherever necessary.
- 4) Figures to the right indicate full marks.
- 5) Use of logarithmic tables, slide rule, Mollier charts, electronic pocket calculator and steam tables is allowed.
- 6) Assume suitable data, if necessary.

SECTION - I

- Q1)** a) Compare floating drilling vessels and fixed offshore rigs in brief. [8]
b) Discuss drilling procedure for structural & conductor casing with suitable sketch. [10]
- Q2)** a) Discuss station keeping dynamic positioning system in detail. [8]
b) What are design considerations of offshore platform? [8]
- Q3)** a) Discuss well planning considerations in deepwater drilling wells. [8]
b) Discuss deep water drilling difficulties and well design issues in brief.[8]
- Q4)** Write short note on [16]
a) Environmental forces.
b) Riser system
c) Gas hydrate
d) High pressure and temperature wells.

SECTION - II

- Q5)** a) Discuss floater well control issues and well shut in procedures in brief.[8]
b) Draw subsea well head system. [8]

P.T.O.

- Q6)** a) Discuss design considerations of stage separation in brief. [8]
b) Discuss typical completion string components and their functions in detail. [8]
- Q7)** a) Discuss design considerations for offshore pipe line in brief. [8]
b) Describe with suitable sketch casing cementing operation in deepwater wells. [8]
- Q8)** Write short notes on [18]
a) Subsea BOP stack.
b) Pressure maintenance.
c) Subsea tree.



Total No. of Questions : 12]

SEAT No. :

P1660

[Total No. of Pages : 3

[4164] - 45

B.E. (Mech. / Mech. S/W)

AUTOMOBILE ENGINEERING

(Sem. - I) (2008 Pattern) (Elective - I)

Time :3 Hours]

[Max. Marks :100

Instructions to the candidates:-

- 1) *Answer Q.1 or Q.2, Q.3 or Q.4, Q.5 or Q.6 of Section - I and Q.7 or Q.8, Q.9 or Q.10, Q.11 or Q.12 of Section - II.*
- 2) *Answers to the two sections should be written in separate answer books.*
- 3) *Neat diagrams must be drawn wherever necessary.*
- 4) *Figures to the right indicate full marks.*
- 5) *Use of electronic pocket calculator is allowed.*
- 6) *Assume suitable data if necessary.*

SECTION - I

- Q1)** a) Draw schematic diagram showing the layout of the transmission system of a rear wheel driven car and also of four wheels driven vehicle. [10]
- b) Explain the following terms : [6]
- i) Rolling resistance
 - ii) Gradient resistance
 - iii) Air resistance

OR

- Q2)** a) Show the different types of chassis layouts that are in use car and transport vehicles, explaining how power is transmitting from the engine to the driving wheel. [10]
- b) Name important transport vehicles and describe the salient feature of each. [6]
- Q3)** a) Explain the construction of a multi-plate clutch with the help of sketch. What are the usual troubles with the clutch? Suggest suitable remedies to clutch troubles. [6]
- b) Why it is necessary to maintain a gear box in the automobile. [4]

P.T.O

- c) How dose Hotchkiss drive differ from torque tube drive explain in details. [4]
- d) What is meant by semi floating type rear axial where it is used? [4]

OR

- Q4)** a) With the help of neat sketch explains the operation of singe plate dry clutch. [4]
- b) What is an epicyclic gear box? Describe its principle and working with the help of neat sketch. [6]
- c) What is the necessity of a universal joint in the car. Explain working of any one type. [4]
- d) How do you distinguish between a fluid flywheel and a torque converter? Explain the working of hydraulic torque converter. [4]

- Q5)** a) Sketch and explain the working of power steering system. [6]
- b) With the aid of neat sketches, Explain in detail about construction and working of disk brake system. [6]
- c) What are the advantages of independent suspension? What is the purpose of independent suspension? [4]

OR

- Q6)** a) What are the various types of steering gears? Explain the construction of form of steering gear commonly used in modern car. [6]
- b) Describe in detail constructional features of the tubed and tubeless tyres for automobile use. [4]
- c) What do you mean by automobile air conditioning? What is necessity? Draw simple diagram of automobile air conditioning system. [6]

SECTION - II

- Q7)** a) Explain the procedure of wheel alignment. [4]
- b) What are the causes and remedies of excessive tyre wear. [4]
- c) Describe the causes of the common trouble experienced in the suspension system of an automobile and suggest appropriate remedies in each case. [8]

OR

- Q8)** a) Discuss various types of troubles in connection with automobile wheels and tyres. [4]
b) Discuss how various defects are caused in the braking system of an automobile. Suggest suitable remedies. [6]
c) Explain the probable cause of various steering troubles and suggest suitable remedies. [6]
- Q9)** a) How dose a seat belt enhance safety. Describe clearly the constructional features and working of safety belt. [6]
b) Discuss in detail the function, construction details and types of air bags. [5]
c) Describe various indicating lights provided in the car. [5]

OR

- Q10)** a) Explain the necessity of pedestrian protection. Describe various passive and active systems to achieve the same. [6]
b) Discuss the requirements of automotive headlights and explain how they have been met with in modern designs of headlights. [5]
c) Describe in detail various 'state of the art' vehicle safety systems used in modern car. [5]
- Q11)** a) With a block diagram discuss the operational features of electronics engine management system. [6]
b) Describe in details applications of micro processor in automobile. [6]
c) Enlist sensors and actuators used in modern automobile electronics. [6]

OR

- Q12)** Write note on any three : [18]
a) Electronic engine control
b) Electronic antilock braking system
c) Vehicle motion control
d) Digital cruise control



Total No. of Questions : 12]

SEAT No. :

P1676

[Total No. of Pages : 3

[4164] - 2

B.E. (Civil)

ENVIRONMENTAL ENGINEERING - II

(2003 Pattern) (Sem. - I)

Time :3 Hours]

[Max. Marks :100

Instructions to the candidates:

- 1) *Solve Q.1 or Q.2, Q.3 or Q.4, Q.5 or Q.6 from section I and Q.7 or Q.8, Q.9 or Q.10, Q.11 or Q.12 from section II.*
- 2) *Answers to the two sections should be written in separate books.*
- 3) *Neat diagrams must be drawn wherever necessary.*
- 4) *Figures to the right indicate full marks.*
- 5) *Use of logarithmic tables, slide rule, Mollier charts, electronic pocket calculator and steam tables is allowed.*
- 6) *Assume suitable data, if necessary.*

SECTION - I

- Q1)** a) Write a short note on runoff losses and how these are calculated? [6]
b) The BOD_5 of waste has been measured as 450 mg/l. If rate constant is 0.12, Find out ultimate BOD and 3 day BOD at 27°C. [6]
c) Write a short note on testing of sewers. [4]

OR

- Q2)** a) What is a treatability index? Explain the significance of treatability index. [6]
b) What are physical, chemical and biological characteristics of wastewater? [6]
c) Explain procedure of B.O.D. test. [4]

P.T.O.

- Q3)** a) Give a list of methods available for treatment of sewage both for rural and urban conditions. [6]
- b) What are the physical changes observed at zone of degradation, zone of decomposition and zone of recovery at a polluted stream? [6]
- c) Explain different treatment units in preliminary treatment of waste water. [4]

OR

- Q4)** a) A screen consisting of 10 mm diameter bars, at a clear spacing of 40 mm, treats a maximum hourly flow of 1200m³, velocity of flow through screen chamber = 75cm/sec. Work out: [8]
- i) Width and number of bars.
- ii) Head loss in the chamber.
- b) Explain in a brief various methods of final disposal of sludge. [4]
- c) What is the difference between preliminary and primary treatment of wastewater? [4]

- Q5)** a) What is meant by activated sludge? Describe with sketch the treatment of the sewage by activated sludge process (ASP). [6]
- b) Describe the advantages and disadvantages of ASP. [6]
- c) Explain the various methods of aeration used in activated sludge process. [6]

OR

- Q6)** a) What do you understand by secondary treatment of waste water? Enumerate the various treatment techniques used for biological treatment. [6]
- b) Explain with sketch the construction and working of a conventional trickling filter. [6]
- c) What is the difference between high rate and low rate trickling filters? [6]

SECTION - II

- Q7)** a) Explain diagrammatically the algae-bacteria symbiotic relations. [8]
- b) Distinguish clearly between the working of an oxidation ditch and oxidation pond. [8]

OR

- Q8)** a) Explain the mechanism of purification in facultative oxidation pond. [8]
b) What are the different methods of aerations in the treatment of aerated lagoons? [8]

- Q9)** a) Discuss the criteria for design of a septic tank. [6]
b) Draw a neat sketch of septic tank (Plan & Elevation) and explain its working. [6]
c) What are the suitable conditions and situations to propose septic tank unit for the sewage treatment? [4]

OR

- Q10)** a) What are the advantages and disadvantages of anaerobic treatment? [6]
b) What are the various gases generated in anaerobic digesters and their percentage? [6]
c) Explain the process of UASB. [4]

- Q11)** a) Draw a flowchart for treating paper mill waste water. [6]
b) Discuss the characteristics of distillery spentwash. [6]
c) Explain equalization and proportioning. [6]

OR

- Q12)** a) Explain any one method of hazardous waste treatment. [6]
b) Explain the benefits of waste minimization. [6]
c) What is the difference between grab and composite sample? Explain. [6]



Total No. of Questions : 12]

SEAT No. :

P1678

[Total No. of Pages : 2

[4164] - 251
B.E. (Computer)
DESIGN AND ANALYSIS OF ALGORITHMS
(2003 Pattern) (Sem. - I)

Time : 3 Hours]

[Max. Marks : 100

Instructions to the candidates:-

- 1) *Answer three questions from each section.*
- 2) *Answers to the two sections should be written in separate answer books.*
- 3) *Figures to the right indicate full marks.*
- 4) *Assume suitable data if necessary.*

SECTION - I

- Q1)** a) State whether the function is CORRECT or INCORRECT and justify your answer : **[6]**
- i) $10n^2 + 4n + 2 = O(n^2)$.
 - ii) $3n + 2 = O(n)$
 - iii) $100n + 6 = O(n)$
- b) Prove that $a_m n^m + \dots + a_1 n + a_0$ then $f(n) = O(n^m)$ **[6]**
- c) Prove by mathematical induction “every positive integer can be expressed as a product of prime numbers”. **[6]**

OR

- Q2)** a) Explain building a heap and maintaining the heap property. **[6]**
- b) Solve the recurrence :
- $$\begin{aligned} t(n) &= 0 && \text{if } n = 0 \\ &= 1 && \text{if } n = 1 \\ &= 3t_{n-1} - 1 + 4t_{n-2} && \text{otherwise} \end{aligned}$$
- [8]**
- c) Explain the asymptotic notations : **[4]**
- i) Ω
 - ii) θ
- Q3)** a) Let $n = 5$, $(p_1, \dots, p_5) = (20, 15, 10, 5, 1)$ And $(d_1, d_2, \dots, d_5) = (2, 2, 2, 3, 3)$. Find the optimal solution with prove it. **[8]**
- b) Write a Binary search & Linear search algorithm and analyze the same to find out its worst case, average case and best case complexity. **[8]**

P.T.O.

OR

- Q4)** a) Enlist & explain in detail the general characteristics of greedy algorithm. [8]
b) Write Prim's algorithm. Comment on its time complexity. [8]
- Q5)** a) Define multistage graph. What is a multi - stage graph problem? [4]
b) Can we make use of dynamic programming for graph coloring problem? Explain. [4]
c) Give an algorithm to solve travelling salesman problem using dynamic programming. [8]

OR

- Q6)** a) What is the essential difference between dynamic programming and Recursion? Explain. [4]
b) Write a function to compute length of shortest paths of a given graph. [8]
c) Define following terms [4]
i) Principle of optimality.
ii) Implicit & explicit constraints.

SECTION - II

- Q7)** a) Explain how branch and bound can be used to solve Knapsack problem? [8]
b) Write an algorithm to solve n queen problem to using backtracking. [8]

OR

- Q8)** a) Write a recursive Backtracking algorithm for sum of subsets problem. [8]
b) Explain Backtracking solution to the 0/1 Knapsack problem. [8]
- Q9)** a) Explain in detail Parallel evaluation of expression. [8]
b) Write an algorithm for prefix computation. Determine its time complexity. [8]

OR

- Q10)** a) Prove the problem of determining whether a Boolean expression is satisfiable is NP complete. [8]
b) Consider the expression : $((7 - (21/3))^*3) + ((9 * (10 - 8)) + 6)$. Explain how it can be evaluated in parallel. [8]
- Q11)** a) What is Satisfiability problem? Explain in detail. [10]
b) Write Non deterministic Knapsack algorithm. [8]

OR

- Q12)** a) Prove that Hamilton cycle is in NP. [8]
b) Write short notes on Cook's Theorem. [6]
c) State & explain NP Hard Problem. [4]



Total No. of Questions : 12]

SEAT No. :

P1711

[Total No. of Pages : 2

[4164] - 105

B.E. (Electronics Engineering)
EMBEDDED SYSTEMS DESIGN
(Sem. - I) (2003 Pattern) (Elective - I)

Time : 3 Hours]

[Max. Marks : 100

Instructions to the candidates:-

- 1) *Answer any three questions from each section.*
- 2) *Answer three questions from Section - I and three questions from Section - II.*
- 3) *Answers to the two sections should be written in separate books.*
- 4) *Neat diagrams must be drawn wherever necessary.*
- 5) *Figures to the right indicate full marks.*
- 6) *Your answers will be valued as a whole.*
- 7) *Use of logarithmic tables, slide rule, Mollier charts, electronic pocket calculator and steam tables is allowed*
- 8) *Assume suitable data, if necessary.*

SECTION - I

- Q1)** a) Explain the design metrics of an Embedded System. [10]
b) Explain the protocol architecture of IrDA. [8]
- OR
- Q2)** a) What is an Embedded System? How are they classified? Explain the building blocks of Hard ware in Embedded system. [10]
b) Explain the protocol architecture of IrDA. [8]
- Q3)** a) Describe the processor selection criteria for an Embedded system with proper examples. [10]
b) What are the characteristics of shared data bus? Explain. [6]
- OR
- Q4)** a) Explain the activities of an embedded operating system. [8]
b) Explain the software architecture of an embedded system. [8]

P.T.O

- Q5)** a) Explain the productivity tools for developing software systematically. [8]
b) Explain the architecture of Network Processor. [8]

OR

- Q6)** a) Explain the different types of ROM and RAM devices used in Embedded systems. [8]
b) What is task? What are different task states? Draw a task state diagram. [8]

SECTION - II

- Q7)** a) Explain the methods of protection of shared data. [7]
b) Discuss the scheduling algorithms. [7]
c) Explain interrupt routines in an RTOS environment. [4]

OR

- Q8)** a) Explain the features of UCOS. [8]
b) What are the different time delay functions? Explain. [6]
c) Explain deadly embrace. [4]

- Q9)** a) What is RT Linux Module? Explain. [4]
b) What are the function calls provided for times management in RT Linux? Explain. [6]
c) How does a mailbox message differ from queue message in UCOS? Explain. [6]

OR

- Q10)** a) Explain the following functions UCOS
i) Task related functions ii) Timer related functions. [8]
b) Explain the memory management functions of RTOS. [8]

- Q11)** Explain the embedded system used in Digital Camera. [16]

OR

- Q12)** a) Explain with a neat diagram of an adaptive cruise control system in a car. [8]
b) Explain the basic features of smart card Hardware. [8]



Total No. of Questions : 12]

SEAT No. :

P1712

[Total No. of Pages : 3

[4164] - 127

B.E. (E & TC)

ADVANCED DIGITAL SIGNAL PROCESSING

(Sem. - I) (2003 Pattern) (Elective - I)

Time : 3 Hours]

[Max. Marks : 100

Instructions to the candidates:-

- 1) Answers to the two sections should be written in separate books.
- 2) Neat diagrams must be drawn wherever necessary.
- 3) Figures to the right indicate full marks.
- 4) Use of logarithmic tables, slide rule, Mollier charts, electronic pocket calculator and steam tables is allowed
- 5) Assume suitable data, if necessary.

SECTION - I

- Q1)** a) Explain, with an example, why is a discrete time signal filtered prior to downsampling? Illustrate with frequency spectrum. [8]
- b) With neat block diagram, waveforms and equations, explain the sampling rate conversion by non-integer factors. [8]

OR

- Q2)** a) Explain, with suitable diagrams, the polyphase implementation of interpolators. [8]
- b) Explain, with neat diagrams and flowcharts, how computational effort is reduced by a factor of M, in decimator, where M is decimating factor. [8]

- Q3)** a) Derive the expression for basic LMS algorithm. [10]
- b) Write LMS algorithm for system identification configuration. [6]

OR

- Q4)** a) Explain, how adaptive filters are used for removing ocular artefacts from human EEG. [8]
- b) Explain the recursive least squares (RLS) algorithm. [8]

P.T.O

- Q5)** a) Write a note on Forward Linear Prediction. [4]
 b) Determine the reflection coefficients for the sequence whose autocorrelation function is given by : [10]
 $[2 \ -3 \ 1 \ 15 \ 1 \ -3 \ 2]$
 c) Why Levinson & Durbin algorithm is used to obtain the filter coefficients in the autocorrelation method of linear Prediction. [4]

OR

- Q6)** a) Determine the parameters $\{k_m\}$ of the lattice filter corresponding to the FIR filter described by the system function. [6]
 $H(z) = 1 + 2z^{-1} + z^{-2}$
 b) Write a note on Inverse Linear Predictor. [4]
 c) Draw Lattice and Direct Form I FIR filter structure. Derive the equations which convert lattice filter coefficients to direct form filter coefficient. [8]

SECTION - II

- Q7)** a) Explain the use of D.F.T. in power Spectrum Estimation. Illustrate the effect of window function on DFT of a discrete time sequence. [8]
 b) Suppose we have $N = 1000$ samples from a sampled sequence of random process. [8]
 i) Determine the frequency resolution of the Bartlett and Welch (50% overlap) methods for a Quality factor of 10.
 ii) Determine the segment length for the Bartlett and Welch (50% overlap) methods.
 iii) Compare Bartlett & Welch methods of power spectrum estimation.

OR

- Q8)** Explain the Periodogram method of power spectrum estimation. What are its limitations? Explain Welch method. [16]
Q9) a) What are the desirable features of a Digital Signal processor. [9]
 b) With the help of a 'C' language Pseudocode, explain the process of FIR filtering in DSP. [9]

OR

Q10) a) The unquantised coefficients of IIR filter are as follows : **[4]**

$$b_{01} = 1 \qquad a_{11} = -0.829328$$

$$b_{11} = 0.675718 \qquad a_{21} = 0.307046$$

$$b_{21} = 1$$

Determine the coefficients, if the same are quantized to 16 bits.

- b) What are the factors considered for selecting a Digital signal processor for an application. **[8]**
- c) List the important features of TI TMS 320C5416 processor. **[6]**

Q11) a) Explain the digital model of speech production. **[6]**

- b) Define pitch w.r.t. speech signal. Determine pitch frequency, given the following data. **[6]**

$$F_s = 16 \text{ kHz}$$

First maximum of autocorrelation function of speech frame is at lag = 71.

- c) Write a note on Cepstrum. **[4]**

OR

Q12) a) Explain the method of detection of voiced or unvoiced sound in speech frame. **[8]**

- b) A phoneme whose pitch is 100 Hz is sampled at 6kHz. It has two formats, a weak one at 500 Hz and a stronger one at 2 kHz. **[8]**

- i) Determine the discrete time pitch period.
- ii) Sketch the approximate pole locations and frequency response of linear prediction filter.



Total No. of Questions : 12]

SEAT No. :

P1713

[Total No. of Pages : 3

[4164] - 186

B.E. (Chemical)

BIOPROCESS ENGINEERING

(Sem. - I) (2003 Pattern) (Elective - I)

Time :3 Hours]

[Max. Marks :100

Instructions to the candidates:-

- 1) *Answer 3 questions from each section*
- 2) *Answers to the two sections should be written in separate books.*
- 3) *Neat diagrams must be drawn wherever necessary.*
- 4) *Figures to the right indicate full marks.*
- 5) *Use of electronic pocket calculator is allowed.*
- 6) *Assume suitable data, if necessary.*

SECTION - I

- Q1)** a) Explain the role of DNA in cell life cycle? [6]
b) Write down general structure of monosaccharides and their function?[6]
c) Discuss the steps in the growth of microbial cells? [6]

OR

- Q2)** a) Explain the structure and functions of biomembranes? [8]
b) Write short notes on following : [10]
i) Cell fractionation
ii) Osmoregulations interacting toxins

- Q3)** Explain the manufacturing process for. [16]
a) Proteins and
b) Vinegar

OR

- Q4)** Explain the manufacturing process for. [16]
a) Alcohol and
b) Penicilin

P.T.O

- Q5)** a) The following data were obtained for an enzyme-catalyzed reaction. Determine V_{\max} and K_m . The initial rate data is as follows :

S (mol/l)	5×10^{-4}	2×10^{-4}	6×10^{-5}	4×10^{-5}	3×10^{-5}	2×10^{-5}	1.6×10^{-5}	1.0×10^{-5}	8×10^{-6}
γ ($\mu\text{mol}/\text{min}$)	125	125	121	111	96.5	62.5	42.7	13.9	7.5

Do these data fit into Michaelis-Menten kinetics? If not what kind of rate expression would you suggest? Use graphical method. [8]

- b) Explain the kinetics of substrate activation and inhibition? [8]

OR

- Q6)** a) Give kinetic expressions for single and double displacement reactions and discuss the Lineweaver Burke plot for both the cases? [8]

- b) Explain the deactivation kinetics models? [8]

SECTION - II

- Q7)** a) Write a note on other forms of microbial growth kinetics? [10]

- b) Explain the typical growth curve for bacterial population? [8]

OR

- Q8)** a) Derive design equation for CSTR for continuous cultivation of cells and also explain Monod kinetics? [10]

- b) Derive an expression for maximum possible dilution rate and also state its significance? [8]

- Q9)** a) What is immobilization of enzymes? What are its advantages over free enzymes? [8]

- b) What are the different variants of continuously operating bioreactors? Explain in brief? [8]

OR

- Q10)** a) Explain the different methods of enzyme immobilization? [8]

- b) Discuss and compare mechanically agitated contactor and bubble column reactor as fermentor? [8]

- Q11)** a) Discuss solvent extraction with examples used in bioseparations? [8]
b) Describe the procedure for calculating the maximum possible growth rate and critical mass transfer coefficient? [8]

OR

Q12) Write short notes on : [16]

- a) Dialysis
- b) Reverse osmosis
- c) Electrophoresis
- d) Ultra-filtration



Total No. of Questions : 12]

SEAT No. :

P1717

[Total No. of Pages : 3

[4164] - 254
B.E. (Computer Engineering)
PRINCIPLES OF COMPILER DESIGN
(2003 Pattern) (Sem. - I)

Time : 3 Hours]

[Max. Marks :100

Instructions to the candidates:

- 1) *Answers to the two sections should be written in separate books.*
- 2) *Assume suitable data, if necessary.*

SECTION - I

- Q1)** a) Discuss the significance of lexemes with longest prefix and significance of ordering rules with suitable examples. [6]
- b) Explain LEX with suitable example. [6]
- c) Why white space characters are generally not allowed in identifier names. Justify. [3]
- d) Explain Gross compiler. [3]

OR

- Q2)** a) Explain following points with respect to compiler : [16]
- i) Grouping of phases.
 - ii) No. of passes required.
 - iii) Intermediate languages.
 - iv) Tools needed.
- b) What is lexical error? [2]

- Q3)** a) Consider the grammar

$$E \rightarrow E + E$$

$$E \rightarrow E \times E$$

$$E \rightarrow a$$

Remove the ambiguity and then construct SLR(1) parsing table for the resulting grammar. Show the step wise functioning for the SLR(1) parser designed for "a × a + a" [12]

- b) Explain different types of parser. [4]

OR

P.T.O.

- Q4)** a) Explain left recursion and left factoring. [4]
b) Construct a LR(0) parsing table for following grammar [12]
 $S \rightarrow iS eS \mid iS \mid a$
where 'i' stands for 'if expression than'
'e' stands for 'else'
'a' for all other productions.
Show the steps taken by parser on input 'iaea'.

- Q5)** a) Write syntax directed translation scheme for
i) if E then S
ii) if E then S else S
iii) do S while E
Where E can be arithmetic or condition expression or identifier or number. Expression may contain mixed types. Proper precedence and associativity can be taken into consideration. S is simple assignment statement. [12]
b) Explain any two types of intermediate code. [4]

OR

- Q6)** a) What is S-attributed definition and L-attributed definition? How conversion of L-attributed to S-attributed is done [6]
b) Give merits and demerits of triples and quadruple representation scheme. [6]
c) Differentiate between syntax tree and DAG. [4]

SECTION - II

- Q7)** a) What are typical contexts of activation record? By taking example of factorial program, explain how activation record will look like for every recursive call in case of factorial (3). [10]
b) What are the uses of symbol table during whole compilation process. Comment on "Symbol table is used even after the end of compilation process". [8]

OR

- Q8)** a) Explain following parameter passing methods with suitable example:[6]
i) Call by value.
ii) Call by reference
iii) Call by name
b) Explain storage allocation schemes with proper examples : [12]
i) Stack storage allocation
ii) Heap storage allocation
iii) Static storage allocation
- Q9)** a) Explain with example the following terminologies : [8]
Basic block, flowgraph, peephole optimization, call graph.
b) Explain issues in code generation. [8]

OR

- Q10)**a) What is register allocation and assignment? [6]
b) What is 'Next use information'. How it is computed? [5]
c) Explain various transformation on basic blocks. [5]
- Q11)**a) Draw an example flow graph and explain following optimization using it : [12]
i) Copy propagation
ii) Constant folding.
iii) Code hoisting.
iv) Common sub expression elimination.
b) What is data flow analysis? Highlight merit and demerit of code optimization. [4]

OR

- Q12)**a) Explain following related to code optimization [10]
• Register allocation
• Evaluation order
• Algebraic transformations
b) Why loop optimization is an effective tool for code optimization. [6]



Total No. of Questions : 12]

SEAT No. :

P1719

[Total No. of Pages : 2

[4164] - 260

B.E. (Computer Engineering)

ADVANCED COMPUTER ARCHITECTURE AND COMPUTING

(2003 Pattern) (Sem. - II)

Time :3 Hours]

[Max. Marks :100

Instructions to the candidates:-

- 1) *Attempt three questions from Section - I and three questions from Section - II.*
- 2) *Answers to the two sections should be written in separate books.*
- 3) *Neat diagrams must be drawn wherever necessary.*
- 4) *Assume suitable data, if necessary.*

SECTION - I

Q1) a) Compare Flynn's classification and Feng's classification for parallel computer architecture. [8]

b) Derive the expression for speedup and throughput of a pipeline processor? Describe how speedup can be maximized? [8]

OR

Q2) a) Explain features of a uniprocessor system which exploits the parallelism.[8]

b) What is EPIC? Explain features of EPIC architecture with a block diagram.[8]

Q3) a) Using following reservation table [10]

- i) Determine forbidden list F and collision vector C.
- ii) Draw state transition diagram.
- iii) Determine Simple Cycles and Greedy Cycles.
- iv) Determine Minimum Average Latency (MAL).

	1	2	3	4	5	6	7
S1	X						X
S2		X		X			
S3			X		X		
S4				X			X
S5						X	

b) Draw the ultrasparc architecture and explain its features with the concept of RSE. [8]

OR

P.T.O.

- Q4)** a) Explain various types of data hazards observed in pipeline processor. How these hazards could be detected and resolved. [10]
b) Draw and explain VLIW processor architecture. [8]

- Q5)** a) Draw and explain vector processor architecture with multiple function pipes. [8]
b) Explain the issues in vector processing. [8]

OR

- Q6)** a) Explain Cube, Hypercube and Mesh Interconnection Network. [8]
b) Explain the use of matrix multiplication in parallel algorithms for Array Processors with suitable example. [8]

SECTION - II

- Q7)** a) Explain Memory contention and arbitration techniques of multiprocessor architecture. [12]
b) Draw and Describe IBM Power - 4 processor architecture. [6]

OR

- Q8)** a) Compare the characteristics of loosely and tightly coupled multiprocessor architecture? [6]
b) Describe the features and components of COW's and NOW's architecture. [12]

- Q9)** a) Explain message passing program development in Multithreaded Architecture. [8]
b) How simultaneous multithreading, context switching, interleaved multithreading, latency used in multithreaded architecture. [8]

OR

- Q10)** a) Explain Latency Hiding Techniques with respect to multithreaded architecture. [8]
b) Explain message passing program development for shared memory and data parallel programming with suitable example. [8]

- Q11)** a) Explain collective communication functions implemented MPI library with suitable example. [8]
b) Explain classification of parallel algorithms with their features. [8]

OR

- Q12)** a) Compare PVM and MPI message passing libraries and explain communication functions implemented in MPI library. [8]
b) List out language features for parallelism? Explain the features of FORTRAN - 90, OCCAM. [8]



Total No. of Questions : 12]

P1721

SEAT No. :

[Total No. of Pages : 3

[4164] - 262

B.E. (Computer Engineering)

DISTRIBUTED SYSTEMS

(2003 Pattern) (Elective - II) (Sem. - II)

Time : 3 Hours]

[Max. Marks :100

Instructions to the candidates:

- 1) *Answers to the two sections should be written in separate books.*
- 2) *Neat diagrams must be drawn whenever necessary.*
- 3) *Figures to the right indicate full marks.*
- 4) *Use of logarithmic tables, slide rule, Mollier charts, electronic pocket calculator and steam table is allowed.*
- 5) *Assume suitable data, if necessary.*

SECTION - I

- Q1)** a) Explain principal operation of page based distributed shared memory system. [6]
- b) Explain general organization of an Internet search engine into three different layers. [6]
- c) Explain general structure of a distributed system as middleware. [6]

OR

- Q2)** a) Explain different forms of transparency in distributed system. [6]
- b) Explain different basic organizations of processors and memories in distributed computer systems. [6]
- c) Compare between multicomputer operating systems, network operating systems and middleware based distributed system. [6]

- Q3)** a) Explain the steps involved in doing remote computation through RPC. [8]
- b) Explain message oriented transient communication in detail. [8]

OR

P.T.O.

- Q4)** a) Explain two extensions to the original RPC model. [8]
b) Imagine we have a token bucket specification where the maximum data unit size is 1000 bytes, the token bucket rate is 10 million bytes/sec, the token bucket size is 1 million bytes, and the maximum transmission rate is 50 million bytes/sec. How long can a burst of maximum speed last? [8]
- Q5)** a) Compare between iterative name resolution and recursive name resolution. [6]
b) Explain file system operations supported by NFS. [6]
c) Explain how coda solves read-write conflicts on a file that is shared between multiple readers and only a single writer. [4]

OR

- Q6)** a) Suppose that it is known that a specific mobile entity will almost never move outside domain D, and if it does, it can be expected to return soon. How can this information be used to speed up the lookup operation in a hierarchical location service? [6]
b) Compare between coda, plan 9 and xFS. [10]

SECTION - II

- Q7)** a) Explain the difference between physical clock and logical clock with example. [6]
b) Compare between bully and ring election algorithms. [6]
c) To achieve totally ordered multicasting with Lamport timestamps, is it strictly necessary that each message is acknowledged? Explain. [6]

OR

- Q8)** a) Explain clock synchronization algorithms. [6]
b) Compare Centralized, Distributed and Token ring mutual exclusion algorithms. [6]
c) Many distributed algorithms require the use of coordinating process. To what extent such algorithms actually be considered distributed? Explain. [6]

- Q9)** a) Explain how to reach agreement within a process group when one or more of its members cannot be trusted to give correct answers. [8]
b) Explain different classes of failures that can occur in RPC systems. [8]

OR

- Q10)**a) Explain the principle of virtual synchronous multicast. [8]
b) Explain different types of failures in distributed system. [8]

- Q11)**a) Explain CORBA's callback model for asynchronous method invocation. [8]
b) Compare between GRID Computing and Cluster Computing. [4]
c) Explain different types of GRID. [4]

OR

- Q12)**a) Explain different CORBA services. [8]
b) Explain what is GRID and its architecture. [8]



Total No. of Questions : 12]

SEAT No. :

P1722

[Total No. of Pages : 2

[4164] - 275

B.E. (IT)

MOBILE COMPUTING

(2003 Pattern) (Elective - I) (Sem. - I)

Time :3 Hours]

[Max. Marks :100

Instructions to the candidates :

- 1) *Answers to the two sections should be written in separate books.*
- 2) *Neat diagrams must be drawn wherever necessary.*
- 3) *Assume suitable data, if necessary.*

SECTION - I

- Q1)** a) Explain various types of mobilities you know. [8]
b) Explain the concept of Core, Edge and Access network in mobile communication system. [8]

OR

- Q2)** a) Explain various generation of mobile communication system. [8]
b) Explain in detail the concept of frequency reuse. [8]

- Q3)** Explain GSM architecture in detail with appropriate diagram. Also explain all the algorithms used in GSM security. [18]

OR

- Q4)** Write short notes on : [18]
a) Bluetooth
b) Java card
c) IPv6

- Q5)** a) Explain WAP protocol stack in detail. [8]
b) Explain how GSM system can be upgraded to GPRS. [8]

OR

P.T.O

- Q6)** a) Explain the transmission plane characteristics of GPRS. [8]
b) Explain FHSS and DSSS. [8]

SECTION - II

- Q7)** a) What are the advantages and disadvantages of WLAN? Under what situation is WLAN desirable over LAN? [8]
b) Explain the design issues for applications targeted for handheld devices. [8]

OR

- Q8)** a) Explain in general WLAN architecture. [8]
b) Explain the internal components of PDA. [8]

- Q9)** a) Explain Palm OS architecture. [8]
b) Explain the various layers in Symbian OS. [8]

OR

- Q10)** a) Explain the 3 prong approach used in Java. [8]
b) Explain various security issues used in Symbian OS. [8]

- Q11)** a) Compare SIP and H.323. [9]
b) Explain various attacks on static and dynamic assets. [9]

OR

- Q12)** Write short notes on : [18]
a) Real time Protocols
b) Flavors of Windows CE
c) Components of Information security.



Total No. of Questions : 8]

P1761

SEAT No. :

[Total No. of Pages : 2

[4164] - 204

**B.E. (Petroleum Engineering)
NATURAL GAS ENGINEERING
(2003 Pattern) (Sem. - I)**

Time : 3 Hours]

[Max. Marks :100

Instructions to the candidates:

- 1) Answers to the two sections must be written in separate answer books.*
- 2) Answer three questions from each section.*
- 3) Figures to the right indicate full marks.*
- 4) Neat diagrams should be drawn wherever necessary.*
- 5) Use of a non-programmable calculator is allowed.*
- 6) Assume suitable data, if necessary and clearly state it.*

SECTION - I

Q1) Define Bg, Cg, Tpc. Draw the graph of viscosity, Cg and z factor versus pressure and explain. **[16]**

Q2) What is an inflow performance curve for a gas reservoir? What is an outflow performance curve? What is a tubing intake curve? Plot all on the same graph? What is the usefulness of this graph? Explain in detail with equations. **[16]**

Q3) Explain any two methods to find flowing and static bottom hole pressure. **[18]**

Q4) Derive the gas flow meter equation. **[16]**

SECTION - II

Q5) Draw a process flow diagram showing the removal of carbon dioxide and explain in detail. **[16]**

P.T.O.

Q6) Derive an expression to find equivalent diameter for parallel pipes. [16]

Q7) a) Draw a diagram of a centrifugal compressor and name its parts. [10]

b) Compressor compression cycle. [6]

Q8) Write short notes on : [18]

a) Pipeline insulating.

b) Compressor design.

c) Isochronal well testing.



Total No. of Questions : 12]

SEAT No. :

P1762

[Total No. of Pages : 2

[4164] - 209

B.E. (Petroleum)

PETROLEUM PRODUCTION ENGINEERING - II

(2003 Pattern) (Sem. - II)

Time :3 Hours]

[Max. Marks :100

Instructions to the candidates:-

- 1) Answer Q.No. 1 or Q.No. 2, Q.No. 3 or Q.No. 4, Q.No. 5 or Q.No. 6, from Section - I and Q.No. 7 or Q. No. 8, Q.No. 9 or Q.No. 10, Q.No. 11 or Q.No. 12 from Section - II.
- 2) Answers to the two sections should be written in separate books.
- 3) Neat diagrams must be drawn wherever necessary.
- 4) Figures to the right indicate full marks.
- 5) Use of logarithmic tables, Slide rule, Mollier charts, electronic pocket calculator and steam tables is allowed.
- 6) Assume suitable data, if necessary.

SECTION - I

- Q1)** a) Assume suitable data, draw the schematic graph and explain the graphical method to determine the depth for multipoint of gas injection, in intermittent gas lift. [10]
- b) Draw the schematic sketch of pressure type of gas lift valve and explain its working. [8]

OR

- Q2)** a) Write the various suitable parameters and situation in which you will select PCP, Jet Pump and ESP. [12]
- b) Draw the schematic sketch of four stages involved in intermittent gas lift system operations. Indicate all the features. [6]

- Q3)** a) Explain the working principle and operation cycle of 'plunger assisted gas lift system'. [10]
- b) Explain the working of hydraulic pumping system. [6]

OR

- Q4)** Draw the schematic sketch of surface and subsurface layout of Electrical Submersible Pumping its merits, demerits. Also explain the working of pump, protector, electrical components, gas separator etc. in it. [16]

P.T.O.

- Q5)** a) Explain PPRL and MPRL in SRP. [6]
b) Describe the 'ideal counterbalance effect' in SRP system. [10]

OR

- Q6)** Draw the schematic sketch and explain the working of Sucker Rod Pumping System and its components in brief. [16]

SECTION - II

- Q7)** a) Explain any one method to evaluate well productivity, in brief [9]
b) Explain the methods of well stimulation in brief. [9]

OR

- Q8)** Discuss workover problems and their solution in brief for injection well, SRP well, Gas lift well, gas well and general self producing well. [18]

- Q9)** a) Draw the schematic sketch of gravel packed method of well completion for sand control. [6]
b) What is scale? Write the reasons for scale deposition problem in the well bore. Give the solution in brief. [10]

OR

- Q10)** a) What is nodal analysis? Discuss in brief how it is useful in the evaluation and sizing of surface and sub - surface petroleum production system.[8]
b) What are the reasons of water production through the wellbore? Write the various problems associated with it. [8]

- Q11)** a) Draw the sketch and explain the working of centrifugal pump in brief.[8]
b) Explain Weymouth and Panhandle equations used to calculate pressure drop through pipe lines. Write their assumptions in brief. [8]

OR

- Q12)** Describe in detail pipe line design considerations for the transportation of oil and gas. [16]



Total No. of Questions : 12]

SEAT No. :

P1769

[Total No. of Pages : 4

[4164] - 54

B.E. (Production)
OPERATIONS RESEARCH
(2003 Pattern) (Sem. - I)

Time :3 Hours]

[Max. Marks :100

Instructions to the candidates:-

- 1) *Answer any three questions from each section.*
- 2) *Answers to the two sections should be written in separate books.*
- 3) *Neat diagrams must be drawn wherever necessary.*
- 4) *Figures to the right indicate full marks.*
- 5) *Use of calculator is allowed.*
- 6) *Assume suitable data, if necessary.*

SECTION - I

Unit - I

- Q1)** a) What are the various phases in solving O.R. Problems? **[6]**
- b) A factory manufacture two products 'X' and 'Y' on which the profits earned per unit are Rs. 5 and Rs. 6 respectively. Each product is processed on two machines M1 and M2. Product 'X' requires one minute for processing on M1 and two minutes on M2 while 'Y' requires one minute on M1 and one minute on M2. Machine M1 is available for not more than 460 minutes while M2 is available for not more than 10 hours during any working day. Find the number of units of products X and Y to be manufactured to get maximum profit. **[12]**

OR

- Q2)** a) Explain how linear programming technique can be helpful in decision making in production area. **[6]**
- b) A firm has advertising budget of Rs. 720000. It wishes to allocate this budget to media : magazines and television so that total expose is maximized. Each page of magazine advertising is estimated to result in 60000 exposures whereas each spot on television is estimated to result in 120000 exposures. Each page of magazine advertising costs Rs. 9000 and each spot on television costs Rs. 12000. An additional condition that the firm has specified is that at least two pages of magazine advertising be used and at least 3 spots on television. Determine the optimal media - mix for this firm. **[12]**

P.T.O.

Unit - II

- Q3)** a) “An assignment problem is a special case of transportation problem”. Explain. [6]
b) Using a suitable method, find the optimal solution of the transportation problem. [10]

	D1	D2	D3	Supply
O1	0	2	1	6
O2	2	1	5	7
O3	2	4	3	7
Demand	5	5	10	

OR

- Q4)** a) Explain how travelling salesman problem is solved by using assignment model. [6]
b) The head of the department has five jobs A, B, C, D & E and five coordinates V, W, X, Y and Z. The number of hours each man would take to perform each job is as follows- [10]

Subordinate →	V	W	X	Y	Z
Job A	3	7	10	15	8
Job B	4	7	15	18	8
Job C	8	12	20	20	12
Job D	5	5	8	10	6
Job E	10	10	15	25	10

Find the optimal assignment allocation of jobs to each of the subordinates.

Unit - III

- Q5)** a) Explain the branch and bound method in integer programming problem. [6]
b) Find the solution of following integer LPP. [10]
Maximize $Z = 3X_1 - X_2$
Subject to constraints
 $2X_1 + X_2 \geq 2$
 $X_1 + 3X_2 \leq 3$
 $X_2 \leq 4$ and X_1, X_2 are positive integers.

OR

- Q6)** a) Explain the Gomory’s cutting plane method in integer programming problem. [6]
b) Define or explain the following terms. [10]
i) Parametric programming.
ii) Dynamic programming.
iii) Non linear programming.
iv) Integer programming.
v) Goal programming.

SECTION - II

Unit - IV

- Q7)** a) Explain the steps involved in Monte - Carlo simulation. [6]
b) Find the cost/period of individual replacement policy of an installation of 300 light bulbs. Given that the cost of replacing an individual bulb is Rs. 2. Calculate cost and the number of light bulbs that would fail during each week if the conditional probability of failure per week is as given below.[10]

Week number	0	1	2	3	4
Conditional cumulative probability of failure	0.0	0.10	0.30	0.70	1.0

OR

- Q8)** a) Explain briefly geometric programming. [6]
b) A milk dairy records sales of one liter packets during 100 days are as follows : [10]

Daily demand	8	9	10	11	12	13	14	15	16	17
Number of Days	5	9	10	15	13	8	11	14	8	7

Consider the following sequence of random numbers. Using this sequence, simulate the demand for next 15 days. [23 64 18 96 71 46 54 8 11 81 75 39 28 43 52].

Unit - V

- Q9)** a) What are the properties of a game? Determine the optimal strategies and the value of the game using graphical method if A1, A2 and A3 are strategies of player A and B1, B2, B3, B4 are of player B. [8]

	B1	B2	B3	B4
A1	-5	3	1	20
A2	5	5	4	6
A3	-4	-2	0	-5

- b) What are the characteristics of queuing model? Write Kendal's notations for the models I. [8]

OR

- Q10)** a) What are pure and mixed strategies? Explain the "best strategy" on the basis of minimax criterion of optimality. [8]
b) In the production shop of a company, the breakdown of the machines is found to be Poisson distribution with an average rate of 3 machines per hour. Break down time at one machine costs Rs. 400 per hour to the company. There are two choices before the company for hiring the repairman. One of the repairman is slow but cheep, the other fast but

expensive. The slow repairman demands Rs. 200 per hours and will repair the broken down machines exponentially at the rate of 4 per hour. The fast repairman demands Rs. 300 per hour and will repair machines exponentially at an average rate of 6 per hour. Which repairman should be hired? [8]

Unit - VI

- Q11)** a) Differentiate CPM and PERT. [8]
 b) The following information of a small project is given in number of weeks for completion. [10]

Activity :	1-2	2-3	2-4	3-6	3-5	4-6	5-7	6-7	7-8
Optimistic time :	4	5	4	15	10	8	4	1	6
Most likely time :	6	7	8	20	18	9	8	2	7
Pessimistic time :	8	15	12	25	26	16	12	3	8

Draw the network diagram and calculate variances, the critical path and the expected project length.

OR

- Q12)** a) Write a short note on : [8]
 i) Resource smoothing.
 ii) Crashing of network.
 b) A small project is composed of activities whose time estimates are listed in the table below. Activities are identified by beginning [10]
 i) and ending.
 j) node numbers.

Activity (i - j)	Estimated duration (in days)		
	Optimistic	Most likely	Pessimistic
1-2	1	4	7
1-3	5	10	17
2-4	3	3	3
2-6	1	4	7
3-4	8	15	26
3-5	2	4	8
4-5	5	5	5
5-6	2	5	8

- i) Draw the project network.
 ii) Find the expected duration and variance of each activity and expected project length.
 iii) What is the probability that it would take 5 days more than the expected duration?



Total No. of Questions : 12]

P1770

SEAT No. :

[Total No. of Pages : 4

[4164] - 184
B.E. (Chemical)
PROCESS EQUIPMENT DESIGN - II
(2003 Pattern) (Sem. - I)

Time : 3 Hours]

[Max. Marks :100

Instructions to the candidates:

- 1) *Answer any 3 questions from each section.*
- 2) *Answers to the two sections should be written in separate answer books.*
- 3) *Neat diagrams must be drawn wherever necessary.*
- 4) *Figures to the right indicate full marks.*
- 5) *Use of logarithmic tables slide rule, Mollier charts, electronic pocket calculator and steam tables is allowed.*
- 6) *Assume suitable data, if necessary.*

SECTION - I

- Q1)** a) Describe different types of agitators. **[8]**
- b) Design a shell for jacketed vessel with flanged and dished heads for the following conditions : **[10]**
- | | |
|-----------------------------|-------------------------------------|
| Vessel diameter | 2130 mm |
| Jacket internal diameter | 2260 mm |
| Jacket length | 2500 mm |
| Internal diameter of head | 2130 mm |
| Crown radius | 2130 mm |
| Knuckle radius | 128 mm |
| Straight flange length | 60 mm |
| Internal pressure of shell | 0.55 N/mm ² |
| Internal pressure of jacket | 0.35 N/mm ² |
| Temperature | 150°C |
| Material | Open hearth Steel - (IS 200°C) |
| Allowable stress | 98 N/mm ² |
| Modulus of elasticity | 1.9×10^5 N/mm ² |
| Poisson's ratio | 0.3 |

OR

P.T.O.

- Q2)** a) What are the different types of jackets and their characteristics? [8]
 b) What is the significance of power number and Reynolds number? Give their equations. [4]
 c) Give relevant design equations for half coil jacket and channel type jacket. [6]

- Q3)** a) Give the classification of dryers. Describe tray dryers. [8]
 b) Slabs of a material are dried from one side. Their dimensions are $1\text{m} \times 1\text{m} \times 8\text{mm}$ and the bone dry density of the material is 240 kg/m^3 . The moisture content of the slabs is reduced from 60% to 10% on wet basis. The critical moisture content is 20% and the equilibrium moisture content is 0.5% on wet basis. Find the time required for drying. [8]

OR

- Q4)** a) What are spray dryers used for? Describe them in detail. [8]
 b) What is the function of lifting devices in rotary kiln dryers? Why are rotary kiln dryers given an inclination with the horizontal? [4]
 c) When are vacuum dryers used? How does the vacuum help in such applications? [4]

- Q5)** a) Give the O'Connell's correlation. [6]
 b) What is the effect of the following on plate column design: plate spacing, weir height, vapour velocity and downcomer backup. [10]

OR

Q6) A sieve plate column is to be designed for the separation of a dilute aqueous feed. The following data is available :

Maximum feed rate	10,000 kg/h
Minimum feed rate	70% of maximum
Number of stages	17
Slope of the bottom operating line	5.0
Slope of top operating line	0.57
Top product composition	94 mol%
Bottom Product Composition	Essentially water
Reflux Ratio	1.5
Column efficiency	60%

At bottom conditions:

Vapour Density	0.72 kg/m ³
Liquid Density	954 kg/m ³
Surface tension	0.057 Nm
K_1	0.075

For top conditions :

Vapour Density	2.05 kg/m ³
Liquid Density	753 kg/m ³
Surface tension	0.023 Nm
K_1	0.09
K_2	30.6
Thickness of plate/hole dia.	1
$A_h/A_p = A_h/A_a$	0.1
C_0	0.84

Check for weeping, plate pressure drop, downcomer back-up entrainment. [16]

SECTION - II

- Q7) a) How does channeling and bypassing occur in a packed column? What are its ill effects? How can they be rectified? [6]
- b) From the following data select the appropriate range for N_{OG} and give reasons : [6]
- $y_1/y_2 = 20$
- | | | | | | | |
|------------|-----|-----|-----|-----|------|------|
| mG_m/L_m | 0.5 | 0.6 | 0.7 | 0.8 | 0.9 | 1.0 |
| N_{OG} | 3.7 | 4.1 | 6.3 | 8.0 | 10.8 | 19.0 |
- c) What is the effect of size of packing on the performance of packed column? [6]

OR

- Q8) a) Write about column internals. [8]
- b) In which method for estimation of H_{OG} for a packed column is wetted area considered? Give details. [10]

- Q9) a)** What are the safety devices used in vessels to prevent pressure from exceeding safety limits? [8]
- b) What are knockout drums? What is the function of a demister pad in a vapor-liquid separator? How does it affect design? [8]

OR

- Q10)a)** How can fine suspended solids be separated from gases? Explain. [8]
- b) Design a decanter to separate light oil from water where the water flow rate is 5000 kg/h, density 1000 kg/m³ and viscosity is 1 mN s/m² and the oil flow rate is 1000 kg/h, density 900 kg/m³ and viscosity 2.5 mN s/m². [8]

- Q11)a)** What are the design considerations of natural gas pipelines? [8]
- b) Write a note on piping supports. [8]

OR

- Q12)a)** What are fluid dynamic parameters used in piping design? [8]
- b) What are the requirements of pipeline design under very cold conditions? [8]



Total No. of Questions : 6]

SEAT No. :

P1777

[Total No. of Pages : 2

[4164] - 55

B.E. (Production) (Common to Prod. S/W)

RELIABILITY ENGG.

(2003 Pattern) (Elective - I) (Sem. - I)

Time :3 Hours]

[Max. Marks :100

Instructions to the candidates:-

- 1) *Your answers will be valued as a whole.*
- 2) *Assume suitable data, if necessary.*
- 3) *All questions are compulsory.*

SECTION - I

Q1) In a survival test conducted on 100 cardboard boxes for their strength under impact loading, the following results were obtained. Calculate failure density, hazard rate and reliability. **[16]**

No. of impacts	No. of boxes failed
20	7
22	10
24	15
26	14
29	15
32	13
35	13
37	8
40	5
Total	100

- Q2)** a) An electronic system has a MTBF of 1000 hours and a MTTR of 40 hours. Determine its availability. **[6]**
- b) The random variation with respect to time in the output voltage of a system is exponentially distributed with mean value of 100 V. What is the probability that the output voltage will be found at any time. **[10]**
- i) to lie in the range of 90 - 115 V.
 - ii) exceeding 120 V.

P.T.O.

- Q3)** Find the reliability of the system in Fig. 1 The reliability values of components 1, 2, 3, 4, 5 and 6 are 0.9, 0.92, 0.85, 0.87, 0.82 and 0.95 respectively. [18]

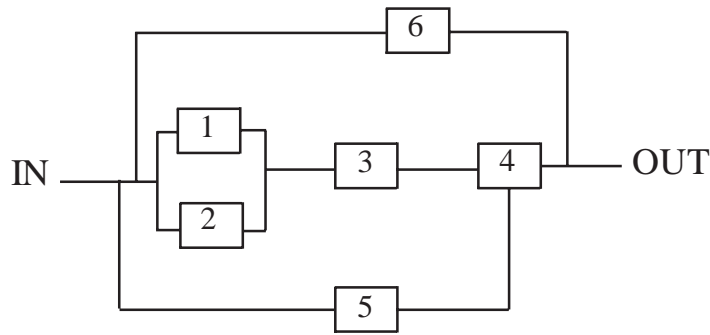

Fig. 1

SECTION - II

- Q4)** Write short notes on any three of the following. [18]
- Active and Passive Redundancy.
 - Reliability and Safety.
 - Accelerated Life Testing.
 - Techno - Physio constraints.
 - Reliability centered maintenance.
 - Use of Markov analysis in Reliability theory.
- Q5)**
- What is meant by 'Bath Tub Curve'? Explain its various phases and their characteristics with few reasons and examples of each. [8]
 - What is meant by Hazard rate? What is its importance and how to determine it? Explain linearly increasing Hazard model and draw the curves for it. [8]
- Q6)**
- 'Maintenance policies should be trad - off between corrective maintenance and preventive maintenance for optimum profit. Do you agree with this statement? Justify with examples. [8]
 - What is RPN in the context of FMEA? Discuss its allocation with an example of your choice. [8]



Total No. of Questions : 12]

SEAT No. :

P1778

[Total No. of Pages : 3

[4164] - 108

B.E. (Electronics)

ADVANCED COMMUNICATION ENGINEERING

(2003 Pattern) (Elective - I) (Sem. - I)

Time :3 Hours]

[Max. Marks :100

Instructions to the candidates:-

- 1) *Answers to the two sections should be written in separate answer books.*
- 2) *Neat diagrams must be drawn wherever necessary.*
- 3) *Figures to the right indicate full marks.*
- 4) *Assume suitable data, if necessary.*

SECTION - I

- Q1)** a) Explain in brief about T-junction. [8]
b) What does u mean by directional coupler? [4]
c) Describe the joints and bends. [6]

OR

- Q2)** a) What is cavity resonator? Discuss. [6]
b) Explain Horn and Parabolic antennas. [8]
c) Which are the microwave sources? [4]

- Q3)** a) Explain in brief : Varactor diode, Pin diode and Tunnel diode. [6]
b) What is MOSFET? [4]
c) Explain MMI in brief. [6]

OR

- Q4)** a) Compare and contrast the following striplines : [8]
i) Micro striplines
ii) Parallel striplines
iii) Coplanar striplines
iv) Shielded striplines
b) Which are the different fabrication techniques of integrated circuits?
Also mention the Hybrid integrated circuit applications. [8]

P.T.O

- Q5)** a) What is Radar? Give fundamentals. [4]
b) List the different types of radars. [6]
c) Explain the following terms : [6]
- Radar equation
 - Radar range

OR

- Q6)** a) Which is system losses related to Radar? Explain in detail. [8]
b) What is Conical scan and sequential lobbing? [8]

SECTION - II

- Q7)** a) What is the nature of light? Explain. [4]
b) What do you mean by acceptance angle and critical angle? Also explain Ray theory. [6]
c) Draw and Explain the block diagram of OFC link. [8]

OR

- Q8)** a) Compare and contrast the step and graded index. [6]
b) Discuss the single and multimode fibers. [6]
c) Explain the OTDR instruments used for OFC. [6]

- Q9)** a) Discuss the Architecture of GSM. [6]
b) Explain cell splitting and handoff mechanism. [6]
c) Explain ARQ technique. [4]

OR

- Q10)** a) What is digital cellular modulation technique? Explain in detail. [8]
b) Discuss the following wireless technologies in brief. [8]
- i) TDMA
 - ii) CDMA
 - iii) WCDMA
 - iv) TDSCDMA

- Q11)** a) How basic satellite communication occurs? Explain in brief. [8]
b) What are satellite orbits and satellite constellations? Discuss. [8]

OR

- Q12)** a) What is the radio link? [4]
b) Explain spectrum sharing. [6]
c) Give and Explain the forecast methods. [6]



Total No. of Questions : 12]

SEAT No. :

P1781

[Total No. of Pages : 3

[4164] - 116

B.E. (Electronics)

SYSTEM PROGRAMMING AND OPERATING SYSTEMS

(2003 Pattern) (Elective - II) (Sem. - II)

Time :3 Hours]

[Max. Marks :100

Instructions to the candidates:

- 1) *Answer any three questions from each section.*
- 2) *Answers to the two sections should be written in separate answer books.*
- 3) *Neat diagrams must be drawn wherever necessary.*
- 4) *Figures to the right indicate full marks.*
- 5) *Use of logarithmic tables, slide rule, Mollier charts, electronic pocket calculator and steam tables is allowed.*
- 6) *Assume suitable data, if necessary.*

SECTION - I

Q1) a) What are the language translator activities. **[8]**

b) Explain the different types of translator. **[8]**

OR

Q2) a) Explain the following term. **[8]**

i) Lexical Analysis.

ii) Semantic Analysis.

b) Explain phases of compiler with input and output of each phase with example \ of assignment statement of 'C' language. **[8]**

Q3) a) Draw the flowchart of activities of pass I of two pass assembler. **[8]**

b) Explain advanced features of Macro assembler. **[8]**

OR

P.T.O.

- Q4)** a) Explain data structures used in Pass I & Pass II of assembler. [8]
b) Describe the design of Macro processor & machine independent features of macro Processor. [8]

- Q5)** a) Define loader? What are the basic tasks of the loader? [6]
b) Differentiate between Absolute Loaders and Direct Linking Loaders. [12]

OR

- Q6)** a) Explain Binary Symbolic Subroutine (BSS) loading scheme with example. Also discuss how allocation, relocation, linking and loading is done using this loading scheme. [8]
b) Explain the significance of the Transfer Vector. [4]
c) Explain with example how fundamental tasks of loading is carried in Direct Linking Loader. [6]

SECTION - II

- Q7)** a) What is OS ? State & Explain the basic functions of an OS. [8]
b) Explain different job scheduling in detail. [8]

OR

- Q8)** a) What is Deadlock? Explain deadlock handling techniques to deal with Deadlock. [8]
b) What is Inter process communication. [4]
c) How semaphore is used in Process synchronization? [4]

- Q9)** a) Explain with diagram the concept of a translation look aside buffer. [4]
b) Explain Virtual memory using paging. [8]
c) Write short note on: [6]
i) Continuous memory allocation.
ii) Non Continuous memory allocation.

OR

Q10) a) Write down the algorithm for page replacement. [8]

b) Explain the concepts of [10]

i) Virtual memory.

ii) Demand Paging.

Q11) a) Explain IO time, access time & transfer time for magnetic tape & disks.

[8]

b) Explain device driver for serial & parallel port. [8]

OR

Q12) a) Explain different requests and responses across the PIOCS interfacing. [8]

[8]

b) Write short note on Advanced I/O programming. [8]



Total No. of Questions : 12]

SEAT No. :

P1782

[Total No. of Pages : 2

[4164] - 280-A

B.E. (Information Technology)

ARTIFICIAL INTELLIGENCE

(2003 Pattern) (Elective - II) (Sem. - II)

Time :3 Hours]

[Max. Marks :100

Instructions to the candidates:-

- 1) *Answers to the two sections should be written in separate books.*
- 2) *Neat diagrams must be drawn wherever necessary.*
- 3) *Assume suitable data, if necessary.*

SECTION - I

- Q1)** a) Discuss the classification of production systems. Comment on Control Strategy. [10]
b) Explain the forward and backward chaining rules. [6]

OR

- Q2)** a) Design the heuristic estimates for: [6]
i) 8-puzzle ii) Chess iii) Tic-Tac-Toe
b) Explain AO* algorithm with example indicating its shortcomings. [10]

- Q3)** a) Explain the procedure of resolution with example. [8]
b) Write a script for viewing the movie in a theatre. [8]

OR

- Q4)** a) Give the procedure to convert wff into clause form. [8]
b) Draw the Partitioned Semantic Net representation for, [8]
i) Every citizen of the town is literate.
ii) The dog has bitten every mail carrier.

P.T.O

- Q5)** a) Explain Morphological analysis and semantic analysis phases of NLP. [10]
b) Write and explain Waltz's algorithm. [8]

OR

- Q6)** a) Give the complete ATN representation to accept assertive English statements. [10]
b) Explain discourse integration and pragmatic analysis phases of NLP. [8]

SECTION - II

- Q7)** a) What is the significance of Planning? Which are the various components of typical Planning system? [8]
b) Elaborate least commitment strategy. [8]

OR

- Q8)** a) Explain Non linear planning with goal stack with example. [8]
b) What is Hierarchical planning? Explain with example. [8]

- Q9)** a) Explain Learning by Analogy and Rote Learning. [8]
b) Explain Back Propagation Neural Network in detail? [10]

OR

- Q10)** a) What is Perceptron Learning? Explain in detail. [8]
b) Write the note on Learning by Deduction and Learning by Induction. [10]

- Q11)** a) Explain typical Medical Diagnosis Expert system to diagnose childhood diseases. [10]
b) Why does Prolog qualify as an AI language? [6]

OR

- Q12)** a) Explain the various building blocks of a typical Expert System. [8]
b) Write a Prolog program to compute the Fibonacci number interactively. [8]



Total No. of Questions : 12]

SEAT No. :

P1801

[Total No. of Pages : 3

[4164] - 16
B.E. (Civil)
CONSTRUCTION MANAGEMENT
(2003 Pattern) (Elective - II) (Sem. - II)

Time : 3 Hours]

[Max. Marks :100

Instructions to the candidates:

- 1) *Answer any 3 questions from each section.*
- 2) *Answers to the two sections should be written in separate answer books.*
- 3) *Neat diagrams must be drawn wherever necessary.*
- 4) *Figures to the right indicate full marks.*
- 5) *Use of logarithmic tables slide rule, Mollier charts, electronic pocket calculator and steam tables is allowed.*
- 6) *Assume suitable data, if necessary.*

SECTION - I

- Q1) a)** Explain with examples the details of various construction projects which are planned, and/or which are in the phase of construction, and/or which are recently completed in the following sub-sectors, in the Indian context : **[12]**
- i) Road
 - ii) Energy
 - iii) Communication
- b) Discuss the responsibilities and authorities possessed by a construction manager managing a multi-storeyed commercial complex. **[6]**

OR

- Q2) a)** Discuss in detail the role played by CIDC as regards **[12]**
- i) Vocational training / development of construction workers.
 - ii) CIDC-CQRA quality assessment.
 - iii) CIDC-ICRA gradings for various stake-holders of projects.
- b) Explain with examples from a contractor's organisation executing road projects, the following : **[6]**
- i) Organising
 - ii) Staffing
 - iii) Controlling

P.T.O.

- Q3)** a) Derive the formula for EOQ and explain limitations of EOQ. [6+4]
b) Discuss role of the materials manager appointed in an organisation manufacturing precast and pre-stressed building components. [6]

OR

- Q4)** a) Explain how you would carry out the MUSIC-3D analysis for a construction organisation which is involved with pre-fabricated construction and steel structures. [8]
b) Discuss overall advantages of JIT concept, but also highlight the limitations of the same in the context of Indian construction projects. [5+3]

- Q5)** a) Discuss with examples the various primary and secondary objectives of materials management and the role of the materials manager in the balancing of objectives. [7+3]
b) Explain graphically with an example the 2 bin system. Also work out the necessary formulae required to operate the system. [6]

OR

- Q6)** a) Discuss various types of feasibility studies carried out for any metro project in India. [10]
b) Discuss role of lender's engineer on capital intensive construction projects. [6]

SECTION - II

- Q7)** Discuss any 4 natural disasters w.r.t. [18]
a) Causes.
b) Effects.
c) Data acquisition process.
d) Mitigation measures.

OR

- Q8)** Discuss any 4 man-made disasters w.r.t. **[18]**
- a) Causes.
 - b) Effects.
 - c) Data acquisition process.
 - d) Mitigation measures.

- Q9)** Explain the various provisions made and how to ensure the effective implementation of the same with respect to the following acts. **[8+8]**
- a) Payment of Bonus Act (1965).
 - b) Indian Arbitration Act (1994).

OR

- Q10)** W.r.t. **[8+8]**
- a) Employees Provident fund Act (1952).
 - b) Minimum wages Act.

- Q11)** Explain in detail how you would identify risk elements, their chance of occurrence and their impact on the project w.r.t. any 8 important risk categories associated with a gravity dam project situated on permeable foundation in an earthquake prone zone. **[16]**

OR

- Q12)** Same requirements but w.r.t. any 8 important risk categories associated with a major marine work of jetty construction under ports and harbour project being executed in the sea. **[16]**



Total No. of Questions : 12]

SEAT No. :

P1802

[Total No. of Pages : 2

[4164] - 198

B.E. (Chemical)

INDUSTRIAL HAZARDS & SAFETY

(2003 Pattern) (Elective - II) (Sem. - II)

Time :3 Hours]

[Max. Marks :100

Instructions to the candidates:

- 1) Answers to the two sections should be written in separate answer books.
- 2) Neat diagrams must be drawn wherever necessary.
- 3) Figures to the right indicate full marks.
- 4) Assume suitable data, if necessary.

SECTION - I

- Q1)** a) Discuss the importance of ingredients of successful safety program and Draw a neat sketch of the same. [8]
b) Explain about role of computers in Industrial safety. [8]

OR

- Q2)** Describe in detail about [16]
a) FAR
b) Dose V/s Response curve.

- Q3)** a) Discuss the importance of Industrial Hygiene in Chemical Industries.[9]
b) Derive the equation to determine the worker's exposure to noise. [9]

OR

- Q4)** a) Focus on Govt. Regulations related to Industrial safety. [8]
b) Determine the TLV for uniform mixture of dust containing. [10]

Dust	Concentration, wt%	TLV in ppcf
A	70	20
B	30	2.7

- Q5)** a) Distinguish between fires & Explosion. [8]
b) What are the different types of fire extinguishers? Give their compositions & specific application. [8]

OR

P.T.O.

- Q6)** Write short notes on **[16]**
a) Fire Triangle.
b) MOC

SECTION - II

- Q7)** Give the design details to prevent fires & explosions and discuss about the explosion proof equipments & instruments. **[16]**

OR

- Q8)** a) Explain the storage & handling of flammable and toxic chemicals. **[8]**
b) Draw a neat sketch of VSP for acquiring runaway reactions data and discuss in detail. **[8]**

- Q9)** Explain the importance of **[16]**
a) Hazard checklist and Hazard survey.
b) Probability theory for Risk assessment.

OR

- Q10)** Discuss in detail about **[16]**
a) Event Trees and Fault Trees.
b) Revealed & Unrevealed failure.

- Q11)** Write short notes on **[18]**
a) Role of computers in industrial safety.
b) Hazard model & Risk data.

OR

- Q12)** Discuss in detail about. **[18]**
a) Tackling of disasters.
b) Risk management routines.



Total No. of Questions : 8]

SEAT No. :

P1161

[Total No. of Pages : 4

[4164] - 4
B.E. (Civil)
STRUCTURAL DESIGN - III
(2003 Pattern) (Sem. - I)

Time :4 Hours]

[Max. Marks :100

Instructions to the candidates:-

- 1) *Answer Q.1 or Q.2, Q.3 or Q.4 in Section - I.*
- 2) *Answer Q.5 or Q.6, Q.7 or Q.8 in Section - II.*
- 3) *Answers to the two sections should be written in separate books.*
- 4) *Figures to the right indicate full marks.*
- 5) *Use of IS 1343, IS 456, IS 3370 & non programmable calculator is allowed.*
- 6) *Neat diagrams must be drawn wherever necessary.*
- 7) *Assume any other data if necessary & mention it at the starting of the answer.*
- 8) *Mere reproduction from IS Code as answer, will not be given full credit.*
- 9) *Assume any other data if required.*

SECTION - I

Q1) a) Explain in brief. [8]

- i) Single degree freedom system.
- ii) Critical damping.

b) A post tensioned prestressed concrete beam section has top flange 650 × 150, web 150 × 600 and bottom flange 350 × 300mm, is simply supported over a effective span of 17m and carries a super imposed load of 13 kN/m over entire span. Calculate extreme fiber stresses in concrete at midspan at initial and final stage. The 7 No. of 12/7 Freyssinet cables having zero eccentricity at supports and c.g. area of steel at 100 mm from soffit of the section and are stressed to initial prestress of 1000 Mpa. Take loss ratio as 0.85 and unit weight concrete as 25 kN/m³. [17]

OR

Q2) a) A mild steel plate of cross section 12mm × 50mm, of length 0.8 m is supporting a load of 150 N through a spring having stiffness K = 100 N/mm as shown in fig (1). Calculate the natural frequency of the system if modulus of elasticity of mild steel is 200 Gpa. [8]

P.T.O.

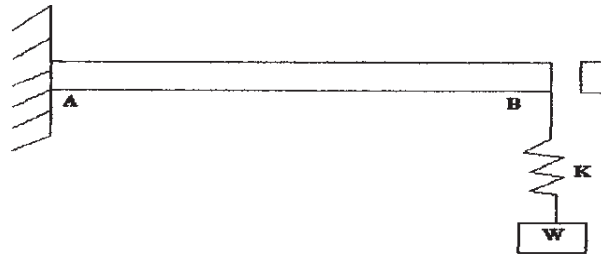

Fig(1)

- b) A post tensioned prestressed concrete beam section has top flange 500×150 , web 125×600 and bottom flange 300×200 mm, is simply supported over a effective span of 16m. The beam is prestressed with 5 No. of 12/5 Freyssinet parabolic cables with their c.g. at 100mm from extreme bottom fiber, stressed one at a time from only one end. Calculate total loss of prestress at the age of 120 days, if initial prestress is 1030 Mpa, coefficient friction = 0.28, $K = 0.0026$ /m length of cable, slip of anchorage = 2mm, $C_c = 2.0$, $E_s = 2 \times 10^5$ Mpa, concrete grade = M40, Creep and relaxation of steel = 2% of initial prestress. [17]

- Q3)** Design a post tensioned prestressed concrete rectangular or 'I' section beam for flexure to carry a live load of 12 kN/m over entire simply supported span of 15m with M40 grade of concrete and Freyssinet cables of 12/5 ($f_y = 1750$ Mpa) or 12/7 ($f_y = 1500$ Mpa), including the design of end block. Draw sketches showing cable profiles and end block reinforcement details. Check fiber stresses in concrete and deflection. [25]

OR

- Q4)** a) State remedial measures to be taken to reduce the friction loss in continuous PSC beams. [8]
- b) A post tensioned prestressed concrete continuous beam ABC with cross section 300×800 mm as shown in fig(2) is prestressed with initial prestressing force of 1500 kN. The loads shown are exclusive of dead load. Locate centerline of thrust under prestress plus dead load also & make it concordant stating the shift of cable at salient points find the stresses in concrete at extreme fibers at intermediate support Take loss ratio of 0.85, $AD = DB = BE = EC = 8$ m. The eccentricities at A & C = 0, at D & E = 240mm (downwards), at B = 150mm (upwards).[17]

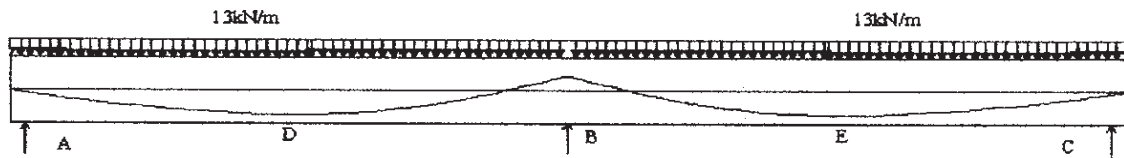

Fig(2)

SECTION - II

- Q5) a) Write detailed note on seismic coefficient method. [8]
- b) Analyze a rigid jointed frame shown in fig (3) by cantilever method for lateral loads. Flexural rigidity for all members is same. Analyze beam JKL using proper substitute frame, if it is subjected to vertical ultimate live & dead load incl. of its self wt. intensities of 13 kN/m & 15 kN/m on JK and 16 kN/m & 18 kN/m on KL respectively. Calculate max. span moment for span JK and support moment at K. Design section for combined effect of vertical and horizontal Loads. Adopt 15% redistribution of moments for vertical load moments Use M20, Fe415.[17]

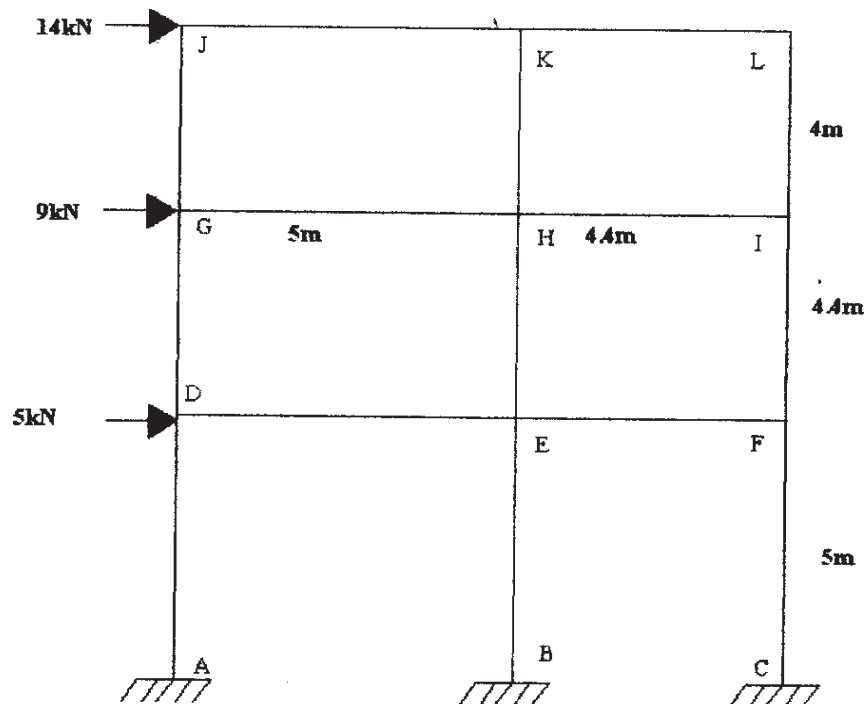

Fig(3)

OR

- Q6) a) Write detailed note on substitute frame method. [8]
- b) Analyze a rigid jointed frame shown in fig(4) by portal method for lateral

loads. Flexural rigidity for all members is same. Analyze beam DEF using proper substitute frame, if it is subjected to vertical ultimate live & dead load incl. of its self wt. intensities of 22 kN/m & 20 kN/m on DE and 16 kN/m & 15 kN/m on EF respectively. Calculate max. span moment for span HI and support moment at E. Design section for combined effect of vertical and horizontal Loads. Adopt 10% redistribution of moments for vertical load moments Use M20, Fe500 [17]

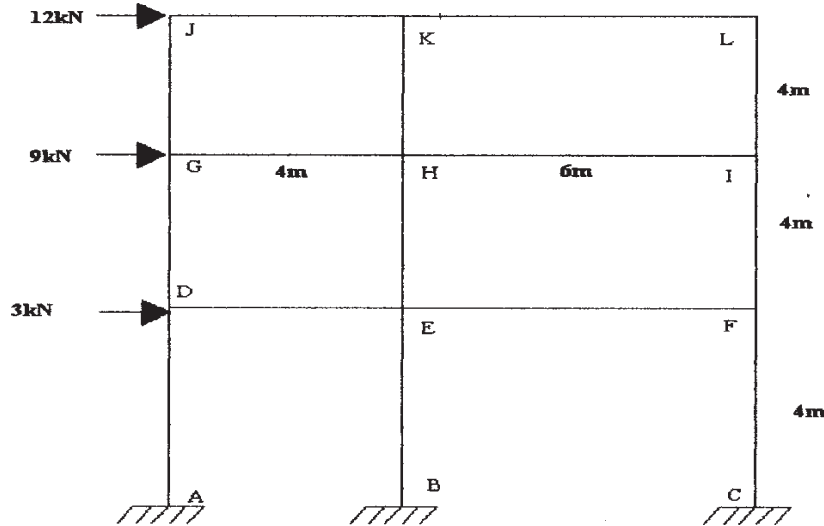

Fig(4)

- Q7) a) Compare rectangular combined footings with strap beam to that without it. [5]
 b) Design circular reinforced concrete tank resting on ground to store 3.25 lakh liters of water the top of tank is open Take the safe bearing capacity of the supporting strata as 180 kN/m². Design the wall and bottom slab of the tank using IS code. Draw all details of reinforcements. [20]

OR

- Q8) Design a 'L' shaped retaining wall for two layered leveled backfill for the following data
 Upper layer, height = 3m, $\phi=30^\circ$, $\gamma = 18 \text{ kN/m}^3$
 Lower layer, height = 3m, $\phi=32^\circ$, $\gamma = 19 \text{ kN/m}^3$
 Safe bearing capacity of the underlying strata = 150 kN/m², The coefficient friction between the base slab and the underlying strata = 0.52. Draw lateral pressure diagram and details of reinforcement of stem and base showing curtailment if any. [25]



Total No. of Questions : 12]

SEAT No. :

P1162

[Total No. of Pages : 3

[4164] - 5

B.E. (Civil)

ADVANCED GEOTECHNICAL ENGINEERING

(Elective - I) (2003 Pattern) (Sem. - I)

Time : 3 Hours]

[Max. Marks : 100

Instructions to the candidates:

- 1) *Answer 3 questions from Section - I and 3 questions from Section - II.*
- 2) *Answers to the two sections should be written in separate answer books.*
- 3) *Neat diagrams must be drawn wherever necessary.*
- 4) *Your answers will be valued as a whole.*
- 5) *Use of logarithmic tables electronic pocket is allowed.*
- 6) *Assume suitable data if necessary.*

SECTION - I

Q1) Explain the following:

[16]

- a) Particle size classification.
- b) Textural classification.
- c) HRB classification.
- d) 'USCS' classification.

OR

Q2) Discuss the following:

[16]

- a) Different 'soil structures'
- b) Role of clay minerals.
- c) Diffuse Double layer.
- d) Granular soil fabric.

Q3) a) Explain 'Culmann's Method' for active earth pressure.

[5]

b) Explain "Poncelet construction" method.

[5]

c) A soil mass is retained by a smooth vertical wall of 6M. Height with properties. $\gamma = 20 \text{ kN/m}^3$ & $\phi = 16^\circ$. The top of soil is horizontal & carries a udl of 4.5 kN/m^2 . Determine the total active EP per meter & its point of application.

[7]

P.T.O.

OR

- Q4)** a) Discuss the steps for 'Design of gravity retaining wall'. [9]
b) Discuss the steps for 'Anchored sheet pile design' by 'Free Earth support' method. [8]

- Q5)** a) Explain the following: [9]
i) Types of geosynthetics.
ii) Functions of geosynthetics.
b) Discuss the following: [8]
i) Functional requirement of geogrid.
ii) Application of geosynthetics in geo-environment.

OR

- Q6)** a) Explain the term 'Reinforced soil' embankment' by drawing a sketch. [9]
b) Discuss the following: [8]
i) 'Binquet & Lee's theory'.
ii) Soil nailing.

SECTION - II

- Q7)** Explain the following: [16]
a) Free & Forced vibrations.
b) Natural Frequency & Amplitude.
c) Barken's method.
d) Pauw's Method.

OR

- Q8)** a) In a vertical block vibration test of $1\text{m} \times \text{m} \times \text{m}$ size, resonance occurred at a frequency of 30 cycles/sec. Determine the C_u if the weight of oscillator is 800 N & the force produced by it after 15 cycles is 1500 N. Weight of test block is 24 kN/m^3 . [8]
b) Explain the following: [8]
i) Elastic half space method.
ii) Evaluation of soil parameters.

- Q9)** a) Explain the steps for ground improvement by compaction piles. [7]
b) Discuss the following: [10]
i) Inserting reinforcement during construction of pile.
ii) Sand drains.

OR

- Q10)**a) Discuss different 'ground improvement techniques'. [10]
b) Explain the term 'grouting'. [7]

- Q11)**a) Discuss 'Basic & composite' Rheological Models. [9]
b) Explain the utility of Rheological models, for determination of creep & secondary consolidation. [8]

OR

- Q12)**a) Discuss the following: [8]
i) Hookian model.
ii) Saint 'Ve-nant's model.
b) Explain the term 'Rheology' & discuss the different soil phenomena, expressed by different Rheological Models. [9]



Total No. of Questions : 12]

SEAT No. :

P1163

[Total No. of Pages : 4

[4164] - 6

B.E. (Civil)

SYSTEMS APPROACH IN CIVIL ENGINEERING

(2003 Pattern) (Common to 1997 Course) (Elective - I) (Sem. - I)

Time : 3 Hours]

[Max. Marks : 100

Instructions to the candidates:-

- 1) Answer 3 questions from Section I and 3 questions from Section II.
- 2) Answer Q1 or Q2, Q3 or Q4, Q5 or Q6 from Section I and Answer Q7 or Q8, Q9 or Q10, Q11 or Q12 from Section II.
- 3) Answers to the two sections should be written in separate answer books.
- 4) Neat diagrams must be drawn wherever necessary.
- 5) Figures to the right indicate full marks.
- 6) Use of logarithmic tables slide rule, Mollier charts, electronic pocket calculator and steam tables is allowed.
- 7) Assume suitable data, if necessary.

SECTION - I

Q1) Solve using Big M or Two phase method

$$\text{Min } Z = 2x_1 + 7x_2$$

Subject to

$$6x_1 + 2x_2 = 5$$

$$5x_1 + 7x_2 \geq 4$$

$$x_1 + 4x_2 \leq 3$$

$$x_1, x_2 \geq 0$$

[16]

OR

- Q2)** a) Explain the use of artificial variables in a L.P. Problem. [4]
- b) Compare Two Phase Method with Big M Method. [6]
- c) Explain infeasible solution and unbounded solution. [6]

P.T.O.

Q3) Solve the following Transportation problem for obtaining the minimum cost of Transportation.

Find the initial feasible solution by least cost method.

[16]

Origin	Destination			
	A	B	C	Supply
1	8	7	5	50
2	7	6	9	50
3	8	6	7	40
4	5	7	6	40
Demand	70	50	60	

OR

Q4) a) A large construction company has to assign five of its subcontractors to five projects. The amount quoted in Rs lakh by each contractor for all the projects are given below. Only one project can be assigned to each contractor. Find the optimal assignment to minimize the total cost. **[10]**

Contractors	Projects				
	1	2	3	4	5
A	14	6	15	11	9
B	11	8	28	18	19
C	19	14	29	21	13
D	26	7	9	16	7
E	9	11	17	21	11

b) Explain degeneracy in a Transportation problem.

[6]

Q5) a) Use Fibonacci method to maximize $Z = x^3 (12 - x)$ in the range (0, 12) within 10% accuracy. Carry out the first four iterations only. **[9]**

b) Explain the Algorithm of Newton's Method. Compare it with steepest gradient method. **[9]**

OR

Q6) a) Use Newton's Method to Minimize $Z = x_1 - x_2 + 2x_1^2 + 2x_1 x_2 + x_2^2$ starting from the point (2, 2) **[9]**

b) Compare the various one-dimensional search techniques in NLP. **[9]**

SECTION - II

- Q7)** a) Use Lagrange Multiplier Technique to Minimize $f(x) = 4x_1^2 + 4x_2^2 + 4x_1x_2 - 12x_1 - 8x_2$ subject to $3x_1 + 2x_2 = 6$. **[10]**
- b) What are the applications of dynamic programming in the field of civil engineering. **[6]**
- c) State Bellman's Principle of optimality. **[2]**

OR

- Q8)** a) It is proposed to develop hydro-power by taking up three different river valley projects. The total budget available is 8 money units. The returns from these projects for each level of investment is given below. Use Dynamic Programming to determine the optimal allocation so that returns are maximized. **[16]**

Budget allocation	Returns from projects.		
	1	2	3
0	0	0	0
2	10	8	11
4	13	17	27
6	32	42	45
8	45	50	55

- b) State the recursive equation at each stage. **[2]**
- Q9)** a) Determine the optimal sequence of jobs, which minimizes the total elapsed time, based on the following information. Find the idle times of Machines B & C.

All jobs are processed in the sequence

A - B - C on the machines.

[10]

Job No.	Processing time on the machines (in minutes)		
	A	B	C
1	5	5	7
2	10	6	10
3	9	4	12
4	7	3	9
5	4	7	8

- b) What are the applications of a sequencing problem in the field of civil engineering? **[6]**

OR

- Q10)**a) What are the components of a queueing system? [6]
b) Explain Kendall - Lee Notation. [4]
c) Explain Monte - Carlo Method of simulation. What are its applications in civil Engg.? [6]

- Q11)**a) Find the optimal strategies and the value of the game for the following pay off matrix to A. [10]

	B1	B2	B3	B4
A1	8	15	-4	-2
A2	19	12	17	16
A3	-4	20	15	5

- b) Explain the dominance theory in games theory. [6]

OR

- Q12)**a) Explain NPV and B/C ratio. Which parameter is to be used under what conditions? [6]
b) Define the following . [10]
i) Internal Rate of Return.
ii) Capital recovery factor.
iii) Sinking fund factor.
iv) Present worth factor.
v) Pay back period.



[4164] - 7

B.E. (Civil)

FINITE ELEMENT METHOD

(2003 Pattern) (Elective - I) (Sem. - I)

Time : 3 Hours]

[Max. Marks : 100

Instructions to the candidates:-

- 1) Answer to the two sections should be written in separate books.
- 2) Figures to the right indicate full marks.
- 3) Neat diagrams must be drawn wherever necessary.
- 4) Use of non programmable calculator is allowed.
- 5) Assume suitable data, if necessary.

SECTION - I

- Q1) a) Determine the forces in the two-bar truss supported by a spring as shown in fig. 1 Take $E = 200 \text{ GPa}$ and $A = 5 \times 10^{-4} \text{ m}^2$. Bar one has a length of 5m and bar two a length of 10m. The spring stiffness is $k = 2000 \text{ kN/m}$.

[12]

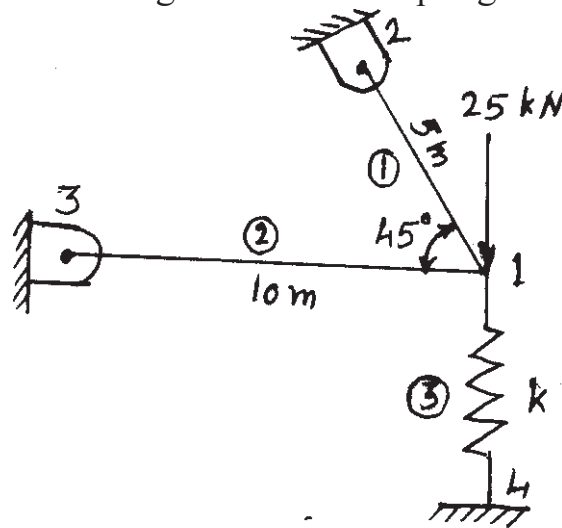

Fig. 1

- b) Examine whether the given displacement model satisfies all the convergence criteria for a beam element. $y = a_0 + a_1x + a_2x^2$ [4]

P.T.O.

OR

- Q2) a) A beam of length 10m, fixed at one end and supported by roller at the other end carries a 20 kN concentrated load at the centre of the span. Take $E = 200 \text{ GPa}$ and $I = 24 \times 10^{-6} \text{ m}^4$, determine deflection, bending moment and shear force at midspan, Also find reactions at supports. [12]
- b) Derive stiffness matrix for a horizontal bar element. [4]

- Q3) For a rigid frame as shown in fig.2, determine the nodal displacement components and rotations, the support reactions and forces in each element. Take $E = 200 \text{ Gpa}$, $I = 8.32 \times 10^{-5} \text{ m}^4$, $A = 6.45 \times 10^{-3} \text{ m}^2$ for all elements. [18]

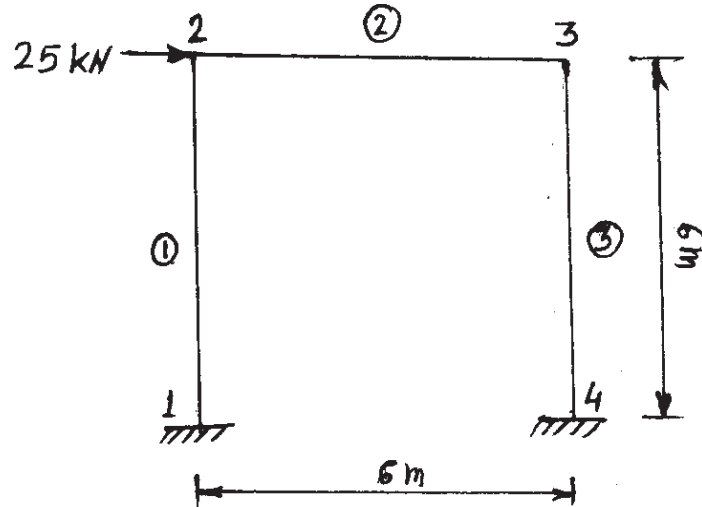

Fig. 2

OR

- Q4) Analyse the grid as shown in fig. 3. The grid consists of two elements, is fixed at nodes 1 and 3, and is subjected to a downward vertical load of 22 kN. Take $E = 200 \text{ Gpa}$, $G = 84 \text{ GPa}$, $I = 16.6 \times 10^{-5} \text{ m}^4$ and $J = 4.6 \times 10^{-5} \text{ m}^4$. [18]

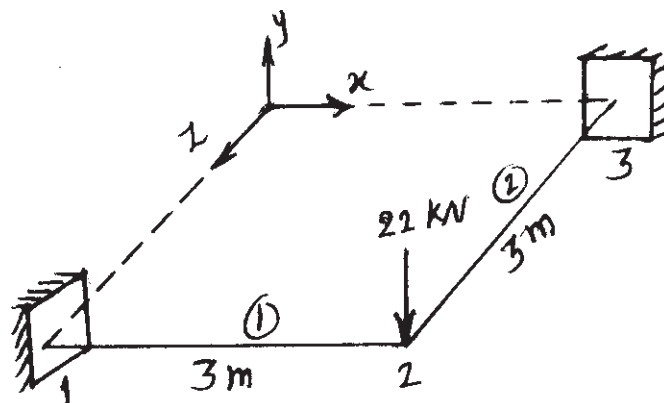

Fig. 3

- Q5)** a) Explain with suitable examples compatible and completeness requirements of displacement function. [8]
 b) Explain two dimensional and three dimensional Pascal's triangle. Explain its use in FEM analysis. [8]

OR

- Q6)** a) Write in brief about 'Finite Element Procedure'. [6]
 b) Determine the shape function for a CST element. Show that they are nothing but area coordinates. [6]
 c) Write a short note on 'Lagrange Function'. [4]

SECTION - II

- Q7)** For the three bar truss shown in fig. 4, determine the nodal displacements and the stress in each member. Take $E = 200 \text{ GPa}$. [18]

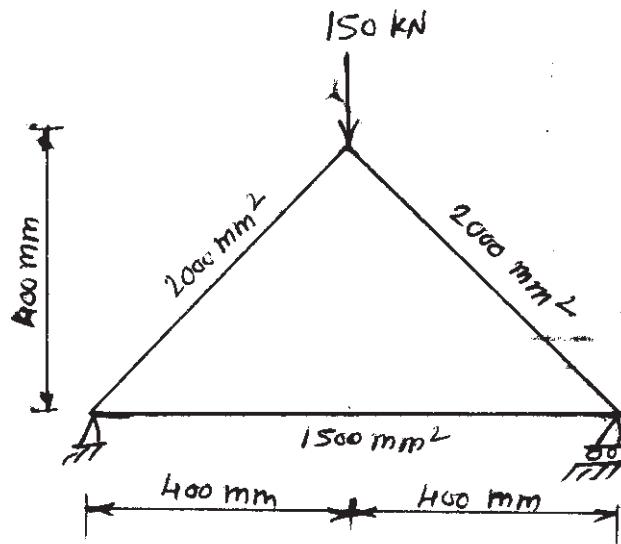

Fig. 4

OR

- Q8)** a) Give the meaning of
 i) Cartesian Parameter Matrix.
 ii) Displacement Transformation Matrix.
 iii) Shape function Matrix. [12]
 b) Derive the shape function for a Tetrahedron Element. [6]
- Q9)** a) Explain the method of finding shape function for 8 noded rectangular element to be used for plane stress/plane strain problem. [8]
 b) using Lagrange functions write shape functions for the nine noded rectangular element. [8]

OR

- Q10)**a) Explain isoparametric elements and their advantages. [6]
b) Write a short note on 'Jacobian matrix' [6]
c) Explain the significance of natural coordinates. [4]

- Q11)**a) Derive strain displacement matrix for CST element. [8]
b) Explain the applications of axisymmetric elements. [4]
c) Can we connect plane stress elements with axisymmetric elements. [4]

OR

- Q12)**a) What are the stress-strain relations for a thick structure, which is axisymmetric in geometry as well as loading. [8]
b) Explain the terms 'Plane stress' and plane strain' problems. Give constitutive laws for these cases. [8]



Total No. of Questions : 8]

SEAT No. :

P1165

[Total No. of Pages : 3

[4164] - 8

B.E. (Civil)

STRUCTURAL DESIGN OF BRIDGES

(2003 Pattern) (Elective - I) (Sem. - I)

Time :3 Hours]

[Max. Marks :100

Instructions to the candidates:-

- 1) *From Section I answer Q.1 or Q.2, Q.3 or Q.4 and from Section II answer Q.5 or Q.6, Q.7 or Q.8.*
- 2) *Answers to the two sections should be written in separate answer books.*
- 3) *Figures in bold to the right, indicate full marks.*
- 4) *IS 456, IS 800, IS 1343 and Steel table are allowed in the examination.*
- 5) *Neat diagrams should be drawn wherever necessary.*
- 6) *If necessary, assume suitable data and indicate clearly.*
- 7) *Use of electronic pocket calculator is allowed.*

SECTION - I

- Q1)** a) Explain the codal provisions of live load specified for highway bridges. **[10]**
- b) List the different types of loads considered in the design of a highway bridge. **[10]**
- c) Explain the different types of bearing used in R.C. bridges. **[5]**

OR

- Q2)** a) Explain how the loads on the longitudinal girders of a T-beam deck slab bridge are assessed. **[10]**
- b) Derive the expression for economic span of a bridge. **[10]**
- c) What are the functions of bearings? **[5]**

- Q3)** Design the deck slab for a R.C. T-Beam deck slab bridge with the given details and also sketch the details of reinforcement. **[25]**

- Carriage way = 2 lanes
- Footpath on either sides = 1.5 m

P.T.O.

- Thickness of railings - 80 mm
- Thickness of footpath - 100 mm
- Thickness of wearing coat - 80 mm
- Span of main girder - 16.0m
- Spacing of cross-beams - 3.0 m c/c
- Live load - IRC Class AA Tracked Vehicle
- Materials - M40 grade of concrete and Fe 415 grade of steel.
- Adopt $m_1 = 0.07$ and $m_2 = 0.05$

OR

Q4) For the R.C. T-Beam deck slab bridge given in Q.3, design the intermediate post-tensioned girder. Use M45 grade of concrete and high tension strands of 7 ply 15.2 mm diameter having an ultimate tensile strength of 1700 N/mm². Use Fe 415 steel for supplementary reinforcement. Consider loss ratio as 0.85. Sketch the details. **[25]**

SECTION - II

- Q5)** a) Compare the advantages of steel bridges over other bridges. **[10]**
 b) Sketch and explain the various components for any five types of steel bridges. **[15]**

OR

- Q6)** a) Design a rocker and roller bearing for the given data and also sketch the details. **[18]**
 i) Reaction from the girder = 2200 kN.
 ii) Allowable pressure on bearings = 4N/mm²
 iii) Allowable pressure on bearing plate = 2100 N/mm²
 iv) Allowable pressure on concrete bed = 5N/mm²
 b) Write a short note on elastomeric pad bearing. **[7]**

- Q7)** Design the members $U_1 - U_2$, $U_2 - L_2$ and $U_1 - L_1$ for the railway steel truss bridge shown in Fig. 7. Also draw a neat sketch of the connection of members at U_1 . **[25]**
 a) Weight of stock rail - 0.60 kN/m
 b) Weight of check rail - 0.40 kN/m
 c) Timber sleepers of size - (0.25 × 0.25 × 2.5)m @ 0.45 m c/c

- d) Unit weight of timber - 7.5 kN/m^3
- e) Spacing of truss - 6.5 m c/c
- f) The bridge supports a eudl of 2950 kN

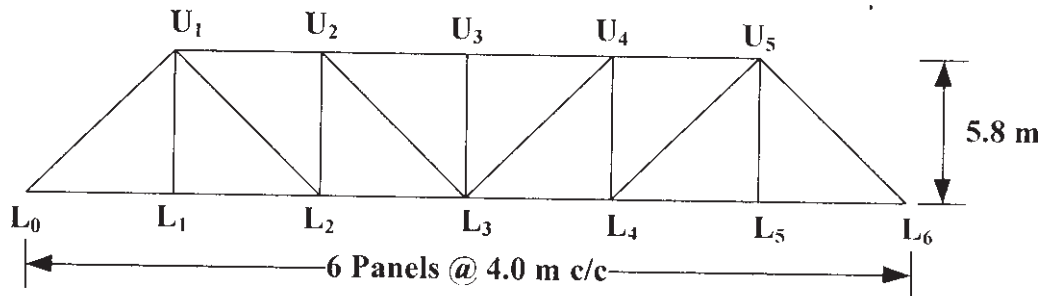

Fig. 7

OR

Q8) For the railway bridge shown in Fig. 7, design the top and bottom lateral bracing with the given data.

The rails are 650 mm above the bottom chord. The chord members are 500 mm deep and 500 mm wide. The end posts are 500 mm deep and 455 mm wide. The web members are 550 mm deep and 250 mm wide. **[25]**



Total No. of Questions : 12]

SEAT No. :

P1166

[Total No. of Pages : 3

[4164] - 10

B.E. (Civil)

ADVANCED ENVIRONMENTAL MANAGEMENT

(2003 Pattern) (Sem. - I) (Elective - I)

Time :3 Hours]

[Max. Marks :100

Instructions to the candidates:-

- 1) *Answer three questions from each section.*
- 2) *Answers to the two sections should be written in separate books.*
- 3) *Neat diagrams must be drawn wherever necessary.*
- 4) *Figures to the right indicate full marks.*
- 5) *Your answers will be valued as a whole.*
- 6) *Use of logarithmic tables, slide rule, Mollier charts, electronic pocket calculator and steam tables is allowed.*
- 7) *Assume suitable data, if necessary.*

SECTION - I

- Q1)** a) Define EMS. What are the benefits of EMS. [6]
b) Write importance of environmental policy for smooth working of EMS. [6]
c) What are key elements of ISO 14001 EMS. [6]

OR

- Q2)** a) Explain following terms with respect to EMS requirements. [12]
i) Planning
ii) Implementation.
iii) Management Review
iv) Checking and correction.
b) What events lead to development of ISO 14000 series. [6]

- Q3)** a) What is the purpose of Air (Prevention and control) Act 1981. Explain in brief how this act helped the state pollution control board to control air pollution. [6]
b) Briefly discuss Hazardous waste Management Handling Act 1989. [6]
c) Explain procedure for sampling under The Water Act. [4]

OR

P.T.O.

- Q4)** a) Explain objectives and provisions in MSW Rules 2000. [6]
b) Briefly discuss the salient features of water (Prevention and Control of Pollution) Act 1974. [6]
c) Explain procedure for sampling under air act. [4]

- Q5)** Explain with examples or chemical formulae for the following physical process to control emission of SO₂ from thermal power plant. [16]
a) Absorption.
b) Catalytic conversion.
c) Adsorption.

OR

- Q6)** a) Explain any two methods of NOX control by treatment. [12]
b) Write emission factor in tabular form. [4]

SECTION - II

- Q7)** Write notes on [18]
a) Composting.
b) Anaerobic digestion.
c) Incineration.

OR

- Q8)** a) Write the classification of hazardous waste. [6]
b) Discuss the suitable methods of collection and disposal of MSW. [12]

- Q9)** Write short notes on [16]
a) Electrodialysis.
b) Ion exchange.
c) Phosphorous removal.
d) Carbon adsorption.

OR

- Q10)** a) What is advanced waste water treatment? Why it is necessary? [8]
b) Explain with a neat sketch GAC treatment of effluent and regeneration of carbon. [8]

- Q11)**a) What are advantages and disadvantages of EIA. [8]
b) Explain procedure for public hearing in India. [8]

OR

Q12) Write positive and negative environmental impacts of following projects. [16]

- a) Nuclear power plant.
b) Express highway.
c) Dam.



Total No. of Questions : 12]

SEAT No. :

P1167

[Total No. of Pages : 4

[4164] - 12

B.E. (Civil)

ADVANCED CONCRETE TECHNOLOGY

(Elective - II) (2003 Pattern) (Sem. - II)

Time :3 Hours]

[Max. Marks :100

Instructions to the candidates:

- 1) *Answer three questions from SECTION I (Que. 1 or 2, Que. 3 or 4, Que. 5 or 6) and Answer three questions from SECTION II (Que. 7 or 8, Que. 9 or 10, Que. 11 or 12).*
- 2) *Answers to the two sections should be written in separate answer books.*
- 3) *Neat diagrams must be drawn wherever necessary.*
- 4) *Figures to the right indicate full marks.*
- 5) *Your answer will be valued as whole.*
- 6) *Assume suitable data, if necessary.*
- 7) *Use of electronic pocket calculator is allowed.*
- 8) *IS 10262 is not allowed.*

SECTION - I

- Q1)** a) Explain the properties of fresh concrete. [6]
b) Explain the water requirement for hydration of cement. [6]
c) Differentiate between rapid hardening cement and low heat cement. [6]

OR

- Q2)** a) Draw and explain the use of grading curves of aggregate. [6]
b) Explain characteristics of aggregates as a concrete making material. [6]
c) Explain alkali aggregate reaction. [6]

- Q3)** a) Name and Explain any four types of light weight concrete. [8]
b) Explain the following terms. [8]
i) Shotcreting. ii) Guniting.
iii) Compaction of concrete iv) Transportation of concrete.

OR

P.T.O.

- Q4) a)** Explain: **[4]**
 i) Mass concrete ii) Vacuum concrete.
 b) Write a note on Under water concreting. **[4]**
 c) Explain: **[8]**
 i) sulphur concrete and sulphur infiltrated concrete.
 ii) high strength concrete and high performance concrete.

- Q5) a)** Using any method, Design the fly ash cement concrete mix M25 for following data. **[10]**

Target mean strength	-33MPa,
Slump	-30 to 60 mm
Maximum size of crushed aggregate	-20 mm,
Exposure	- moderate,
Fly ash to be used	-25%
Concrete cover	-25 mm,

Assume following data:

- Specific gravity of OPC is 3.15 and that of aggregates is 2.65
 - Compressive strength of cement (C) with fly ash (F) is 49 MPa at $W/(C+F)$ as 0.5.
 - For target mean strength of concrete of 33 MPa, $W/(C+F)$ is 0.65.
 - Water content for assumed crushed aggregate of 20 mm size and a slump of 30 to 60 mm is 210 kg/m³.
 - Reduction in water content for use of fly ash is 20%.
 - For assumed exposure and concrete cover, $W/(C+F)$ ratio is 0.5 and cement content is 350 kg/m³.
 - Fine aggregate as 40% and no entrapped air in concrete.
- b) Enlist the any four advanced methods of NDT. Explain any one of them. **[6]**

OR

- Q6) a)** Using IS method, determine mix proportion for M20 concrete for following data. **[10]**
 Target mean strength -26.6 MPa, slump - 30 to 60 mm, size of aggregate - 20 mm, compaction factor - 0.9, quality control - good, exposure - mild ($W/C = 0.5$)
 Cement satisfy the requirement of strength
 CA confirm to table 2 and Fine aggregate confirm to Zone II of IS 383

Specific gravity of OPC and aggregates is 3.15 and 2.6 respectively.

Water absorption for CA and FA is 0.5% and 1% respectively.

Moisture content for CA and FA is 0.0% and 2% respectively.

W/C ratio for target mean strength -0.5

For Sand conforming zone II, Water content is 186 kg/m³ and sand content as 40%. Entrapped air as 2%.

- b) Calculate the quantities of ingredient required to produce 1m³ of concrete of proportion 1: 1.5: 2.8 with w/c ratio as 0.5. Bulk densities of cement, sand and aggregate are 1500, 1700 and 1600 kg/m³ respectively. Assume Entrapped air as 2%. [6]

SECTION - II

- Q7)** a) Explain the historical development of Fiber Reinforced Composite/Concrete (FRC). [6]
b) Enlist different metallic fibers. Explain their any two properties in brief.[6]
c) Explain concept of interaction between fiber and matrix in uncracked condition. [6]

OR

- Q8)** a) Explain carbon fiber and glass fiber. [6]
b) Enlist different naturally occurring fibers. Explain any two in brief. [6]
c) Explain concept of interaction between fiber and matrix in cracked condition. [6]

- Q9)** a) Enlist different properties of hardened FRC. Explain any two. [8]
b) Explain the behavior of SFRC under compression, tension and flexure. [8]

OR

- Q10)**a) Describe the SIFCON material with reference to: definition, structure, properties and use. [8]
b) Explain the quality control test related to FRC. [8]

Q11)a) Explain the construction and use of a precast concrete pole with reference to following: **[8]**

- i) Analysis and design principals
- ii) A material required along with specification.
- iii) Manufacturing method with flow chart.
- iv) Testing methodology.
- v) Quality control.

b) Explain the product fibrocement with reference to following. **[8]**

- i) Analysis and design principals.
- ii) Material required along with specification.
- iii) Manufacturing method with flow chart.
- iv) Testing methodology.
- v) Quality control.
- vi) Use in Civil Industry.

OR

Q12)a) Explain the precast construction products with reference to following. **[8]**

- i) History and development.
- ii) Classification and different product.
- iii) Erection & Assembly.
- iv) Quality Control (Laboratory & field)

b) Explain the construction of bridge (segmental or girder) using precast concrete elements. **[8]**



Total No. of Questions : 12]

SEAT No. :

P1168

[Total No. of Pages : 4

[4164] - 13

B.E. (Civil)

EARTHQUAKE ENGINEERING

(2003 Pattern) (Sem. - II) (Elective - II)

Time : 3 Hours]

[Max. Marks : 100

Instructions to the candidates:-

- 1) From Section I answer Q.1 or Q.2; Q.3 or Q.4; Q.5 or Q.6 and from Section II answer Q.7 or Q.8; Q.9 or Q.10; Q.11 or Q.12.
- 2) Answers to the two sections should be written in separate answer books.
- 3) Figures in bold to the right, indicate full marks.
- 4) IS 456, IS 1893, IS 13920 are allowed in the examination.
- 5) Neat diagrams should be drawn wherever necessary.
- 6) If necessary, assume suitable data and indicate clearly.
- 7) Use of electronic pocket calculator is allowed.

SECTION - I

- Q1)** a) Explain plate tectonic theory. [10]
b) Describe the interior of the earth with a neat sketch. [6]

OR

- Q2)** a) Explain epicenter and focal depth with a sketch. [6]
b) Explain the scales used for measuring the earthquakes. [10]

- Q3)** a) Obtain the solution for the system shown in Fig. 3a [10]

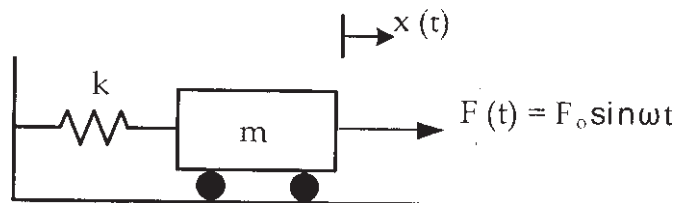

- b) For the mathematical model shown in Fig. 3 b, determine the equivalent stiffness at C. [6]

P.T.O.

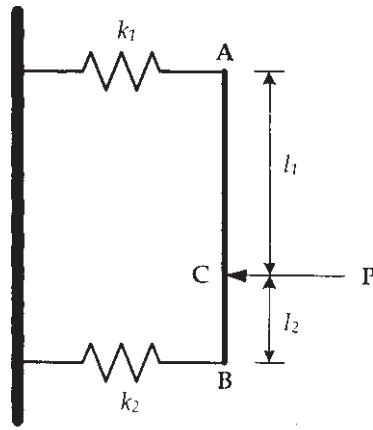

Fig. 3.b

OR

- Q4) a) A machine of mass $m = 350$ kg is mounted on a simply supported steel beam of length $l = 1.75$ m, having a rectangular c/s of $b = 1.0$ m and $d = 0.15$ m and $E = 2.01 \times 10^6$ N/mm². To reduce the deflection of the beam, a spring of stiffness k is attached at the mid-span, as shown in the Fig. 4 a. Determine the value of k . [8]

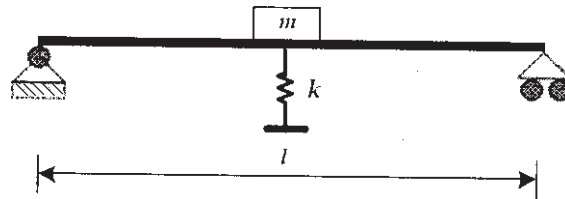

Fig. 4.a

- b) A body with mass of 7.2 kg is suspended from a spring with a constant of 1.80 kN / m. A damper provides a force of 36 N when the mass has a speed of 600 mm / s. Determine the logarithmic decrement of the motion. [8]

- Q5) a) Write a note on shear walls. [10]
 b) Explain with a neat sketch, any one structural arrangement by which the lateral loads on a structure can be resisted. [8]

OR

- Q6) Fig. 6 shows plan of a 6-storey building located in zone IV. Four shear walls are provided to resist the seismic forces. The building has the following data: [18]

- a) Floor to floor height = 3.75 m
 b) Dead load per unit area of floor = 2.5 kN / m²
 c) Live load on each floor = 3 kN / m²
 d) Live load on roof = 2.0 kN / m²

- e) Axial load on each shear wall = 4500 k N
- f) Size of columns = (450 × 450) mm
- g) Soil below the foundation = Medium
- h) Grade of materials = M30 grade of concrete and Fe 415 grade of steel

Design the shear walls.

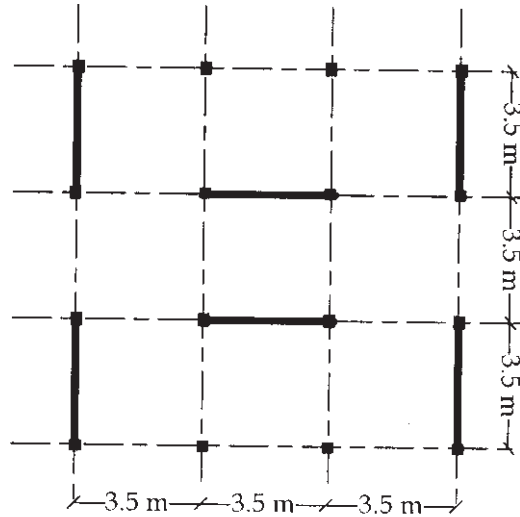

Plan

Fig. 6

SECTION - II

Q7) The G+3 building shown in Fig. 7 is located in seismic zone IV. The floor-to-floor height is 3.5m. The building is supported on medium stiff soil. The R.C. frames are in-filled with masonry walls. The lumped weight due to dead loads is 8 kN/m² on floors and 5 kN / m² on the roof. The floor slabs are designed for a live load of 3 kN / m² and the roof is designed 2 kN / m². Perform dynamic analysis along y-axis only. [18]

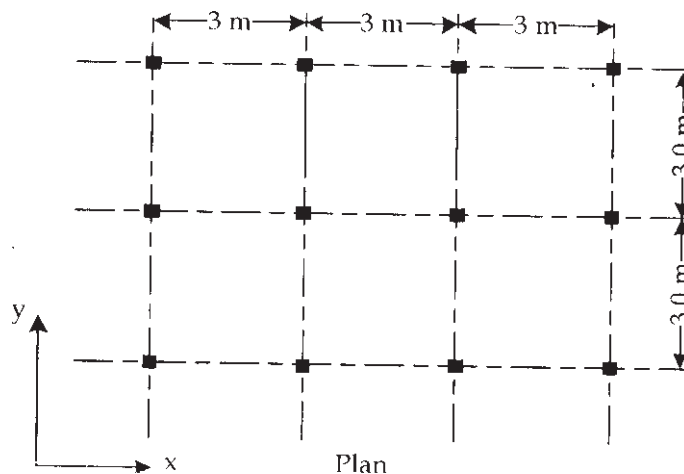

Plan

Fig. 7

OR

- Q8)** a) Explain with neat sketch the detailing of reinforcement at a beam and a column junction. [9]
b) Explain static analysis and dynamic analysis of structure for seismic loads. [9]

Q9) A (500 × 350) mm column is reinforced with 12-16#. It is supported on an isolated footing. The load coming on the footing is 1400 kN and a moment of 30 kNm. The SBC of the soil is 250 kN / m². Using M25 grade of concrete and steel of grade Fe 415, design the footing. [16]

OR

Q10) Explain the various methods available to control the lateral forces acting on a structure. [16]

Q11) Write short notes on [16]

- Soft story
- Plan irregularity
- Mass irregularity
- Liquefaction

OR

- Q12)**a) What is retrofitting and rehabilitation of structures? [8]
b) Write a note on seismic evaluation of structure. [8]



Total No. of Questions : 12]

SEAT No. :

P1169

[Total No. of Pages : 3

[4164] - 17

B.E. (Civil)

INTEGRATED WATER RESOURCES PLANNING AND MANAGEMENT
(Elective - II) (2003 Pattern) (Sem. - II)

Time :3 Hours]

[Max. Marks :100

Instructions to the candidates:-

- 1) Answer any three questions from each Section.
- 2) Answer to the two sections should be written in separate answer books.
- 3) Neat diagrams must be drawn wherever necessary.
- 4) Figures to the right indicate full marks.
- 5) Use of electronic pocket calculator is allowed.
- 6) Assume suitable data if necessary.

SECTION - I

- Q1)** a) Explain in brief the history of water resource development in India. Also explain present institutional framework for water resource management. [8]
b) Write short note on National water policy. [8]

OR

- Q2)** a) Discuss principles of planning and financing of water resource project. [8]
b) Explain occurrence of water in space and time. [8]

- Q3)** a) The concurrent average yearly rainfall over a basin and the corresponding yearly runoff for a period of 18 years are given below. Establish the dependence between yearly rainfall and yearly runoff by computing coefficient of correlation between them. [12]

Year	1	2	3	4	5	6	7	8	9
Rainfall (cm)	113	128	127	104	108	115	167	154	99
Runoff (cm)	74	104	96	61	59	82	109	102	57
Year	10	11	12	13	14	15	16	17	18
Rainfall (cm)	119	152	137	165	151	160	130	149	130
Runoff (cm)	78	109	96	124	103	134	87	106	102

- b) Explain regression analysis in brief. [6]

P.T.O.

OR

- Q4)** a) Explain conventional and evolutionary optimization techniques for water resources planning and management. [10]
b) Explain following statistical parameters. [8]
i) Mean. ii) Standard deviation.
iii) Skewness and iv) Kurtosis.
- Q5)** a) What are the causes of flood. Explain structural and non-structural measures to control floods. [8]
b) Explain use of geo-informatics in of drought management. [8]

OR

- Q6)** Write short notes. (Any four) [16]
a) Discuss common probabilistic distributions with the help of sketches.
b) Reparation rights and ground water ownership.
c) Economics in water resources projects.
d) Principles of water pricing and water allocation.
e) Statistics of water resources and irrigation potential in India.

SECTION - II

- Q7)** a) Explain significance and feasibility of inter-basin water transfer in India. [8]
b) Explain in brief water demand estimation in power sector. [8]

OR

- Q8)** a) Discuss: [8]
i) Consumptive and non consumptive demand in water resource projects.
ii) Method of forecasting of water demands in domestic and industrial sectors.
b) Explain how surface water and ground water resources are estimated. [8]
- Q9)** a) Describe siltation in reservoirs. [6]
b) Explain rehabilitation and resettlement in water resources projects. [10]

OR

- Q10**)a) Discuss principle measures that should be undertaken to control the inflow sediment to an impoundment reservoir. [8]
- b) What is meant by water-logging? What are its ill-effects? Describe some of anti-water-logging measures with the help of suitable sketches. [8]

Q11) Write short notes. (Any 3) [18]

- a) Application of ANN in modeling water resources engineering.
- b) Water management in irrigation sector.
- c) Use of geo-informatics in integrated water resource planning and management.
- d) Social impact of water resources development.

OR

- Q12**)a) Explain use of decision support system in integrated water resource management. [9]
- b) Describe protection of eco-system from environment point-of-view. [9]



Total No. of Questions : 6]

SEAT No. :

P1170

[Total No. of Pages : 2

[4164] - 18

B.E. (Civil)

ADVANCED ENGINEERING GEOLOGY WITH ROCK MECHANICS
(Elective - II) (2003 Pattern) (Sem. - II)

Time :3 Hours]

[Max. Marks :100

Instructions to the candidates:-

- 1) Answer to the two sections should be written in separate answer books.
- 2) Figures to the right indicate full marks.
- 3) All questions are compulsory.
- 4) Neat diagrams must be drawn wherever necessary.

SECTION - I

- Q1)** a) Explain engineering significance of older metamorphic rocks in Maharashtra State. [9]
- b) Branching and off shoots of Dyke. [4]
- c) Field characters of fractures. [5]

OR

Explain

- a) Engineering significance of older secondary rocks in Maharashtra State. [9]
- b) Regional distribution of Basalts. [5]
- c) Field characters of dykes. [4]
- Q2)** a) Geological conditions resulting to tail channel erosion in Deccan Trap Area **Only Mention** Case histories. [7]
- b) Discuss with suitable examples, suitability of Compact and Amygdaloidal Basalts from dam foundation point of view. [9]

OR

- a) Engineering significance of Tachylytic Basalts. [6]
- b) How a location of spillway is decided on local geological conditions. Explain suitable case histories due to Compact basalt and Volcanic Breccias. [10]

P.T.O.

- Q3)** a) Compressive strength of rock masses. [8]
b) R.S.R. system of classification of rock masses. [8]

OR

- a) Stand Up time of a rock mass during tunneling. [3]
b) Wenner's arrangement of resistivity survey. [5]
c) R.M.R. system of classification of rock masses. [8]

SECTION - II

- Q4)** a) Describe Tunneling through Deccan Trap Basalts with examples. [10]
b) The parameters deciding Safe Bearing Capacity of bridge. [8]

OR

- a) Importance of subsurface investigations for foundation of bridges. [10]
b) Significance of dykes and fractures from tunneling point of view. [8]

Q5) Write notes on:

- a) Chances of getting ground water along flow contacts. [4]
b) Scarcity of sand in deccan trap area. [4]
c) Residual soils of Maharashtra State. [4]
d) Granular disintegration. [4]

OR

Explain.

- a) Deep drilled wells. [4]
b) Availability of sand in deccan trap area. [4]
c) Influence of climate on soil formation. [4]
d) Success of percolation tanks in Region 1. [4]

Q6) Write notes on:

- a) Will dam building activity cause a major earthquake. Give suitable examples. [8]
b) Objection and facts about using Amygdaloidal basalt as a construction material. [8]

OR

- a) Engineering significance of fault / faults in major civil engineering works. [8]
b) Giant phenocryst basalt as a construction material. [4]
c) Foundation of monumental buildings. [4]



Total No. of Questions : 12]

SEAT No. :

P1171

[Total No. of Pages : 3

[4164] - 19

B.E. (Civil)

DAMS & HYDRAULIC STRUCTURES

(2003 Pattern) (Sem. - II)

Time :3 Hours]

[Max. Marks :100

Instructions to the candidates:-

- 1) *Answer any 3 questions from each section.*
- 2) *Answer 3 questions from Section I and 3 questions from Section II.*
- 3) *Answers to the two sections should be written in separate books.*
- 4) *Neat diagrams must be drawn wherever necessary.*
- 5) *Figures to the right indicate full marks.*
- 6) *Use of logarithmic tables, slide rule, Mollier charts, electronic pocket calculator and steam tables is allowed.*
- 7) *Assume suitable data, if necessary.*

SECTION - I

- Q1)** a) Explain - procedure of carrying out investigation of dam site. [8]
b) Write short notes on
i) Inclinator
ii) Ballon dams. [8]

OR

- Q2)** a) What is the procedure of fixing height of the dam? [8]
b) Write short notes on [8]
i) Factors that affect the choice of a dam.
ii) Inspection of dams.

- Q3)** a) Compute the maximum stress developed in an elementary profile of a gravity dam 50 m high. Assume triangular uplift with an unlift factor of 0.9. Take $\gamma_{\text{water}} = 9.787 \text{ kN/m}^3$
Sp. gravity of dam material = 2.25 [8]
b) Explain
i) Reservoir Losses
ii) Galleries in gravity dam. [8]

OR

P.T.O.

Q4) a) Check the stability of a gravity dam. 35 m high. Water stands on the u/s side of dam of triangular section upto its full height. The base width of the dam is 20 m.

Assume - 5P wt. of dam material = 24 kN/m^3

Coefficient of friction between bare & foundation $\mu = 0.8$

Shear strength $q = 1200 \text{ kN/m}^2$. [10]

b) Explain low and high gravity dam. [6]

Q5) a) Distinguish between rolled fill and hydraulic fill type earthen dams. [6]

b) Explain various methods of controlling seepage through an earthen dam. [6]

c) Write short note on:
Components of spillway and their functions. [6]

OR

Q6) Write short notes on (any four) [18]

a) Shaft spillway.

b) Roller bucket type energy dissipator.

c) Radial gate.

d) Relationship between TWC and JHC in selection of energy dissipator.

e) Rock toe.

SECTION - II

Q7) a) Explain - various corrections that are needed in the design of weir on permeable foundation, based on Khosla's theory. [10]

b) Explain - Lake tapping. [6]

OR

Q8) a) State limitations of Bligh's creep theory. [8]

b) Explain

i) Control structure - head regulator

ii) Exit gradient. [8]

Q9) a) Give & explain classification of canals. [8]

b) What is the necessity of lining of canals? Explain briefly benefits of lining. [8]

OR

Q10) a) Design an irrigation canal in alluvial soil according to Lacey's theory to carry full supply discharge of $60 \text{ m}^3/\text{s}$. Take Lacey's silt factor = 1.0
Side slope of canal = 0.5 H : 1 V [8]

b) Compare aqueduct and syphon aqueduct. Draw neat sketches also. [8]

Q11) Write short notes on (any three)

[18]

- a) Levees.
- b) Run off river plant.
- c) Draw - Layout of a high head hydro electric power plant & also explain.
- d) Head & cross regulator.

OR

Q12) Write short notes on (any three)

[18]

- a) Types & selection of turbines.
- b) Objectives and methods of river training.
- c) Assessment of power potential.
- d) Groynes.



Total No. of Questions : 12]

SEAT No. :

P1172

[Total No. of Pages : 3

[4164] - 20

B.E. (Civil)

TRANSPORTATION ENGINEERING - II

(2003 Pattern) (Sem. - II)

Time :3 Hours]

[Max. Marks :100

Instructions to the candidates:-

- 1) *Answer Q.1 or Q.2, Q.3 or Q.4, Q5 or Q6 from Section - I & Answer Q.7 or Q8, Q9 or Q10, Q.11 or Q.12 from Section - II.*
- 2) *Answers to the two sections should be written in separate answer books.*
- 3) *Neat diagrams must be drawn wherever necessary.*
- 4) *Figures to the right indicate full marks.*
- 5) *Assume suitable data, if necessary.*

SECTION - I

- Q1)** a) With the help of a neat sketch, describe the concept of star and Grid pattern. [4]
b) Write a detail note on Traffic Volume Study. [6]
c) Describe the method of preparation of Master plan based on saturation system. [7]

OR

- Q2)** a) Explain in brief classification of roads based on location & function.[7]
b) Write a detail note on parking studies. [4]
c) Discuss the salient features of first road development plan. [6]
- Q3)** a) Explain in brief various engineering surveys carried out to finalise road alignment. [7]
b) Calculate the values of [6]
i) Head light sight distance and
ii) Intermediate sight distance for a highway with design speed of 65 kmph. Assume $f = 0.36$ and $t = 2.5$ sec.
c) Write a short note on PIEV Theory. [4]

P.T.O.

OR

- Q4)** a) Derive an expression for finding the Stopping Sight Distance (SSD) at level and at grade. [7]
b) Enumerate the steps for practical design of superelevation. [5]
c) Explain curve resistance and compensation of gradient on horizontal curve. [5]

- Q5)** a) Explain the desirable properties of aggregates to be used in different types of road construction. [6]
b) The CBR value of subgrade soil is 5.0%, calculate total thickness of a pavement using design formula developed by the U.S. corps of engineers. Assume wheel load = 4100 kg and Tyre pressure = 6 kg/cm². [6]
c) State comparison between Rigid pavement and Flexible pavement. [4]

OR

- Q6)** a) Write a note on Equivalent Single Wheel Load. [4]
b) The width of expansion joint gap is 2.5 cm in a cement concrete pavement. If the laying temperature is 10°C, calculate the spacing between expansion joints. Assume coefficient of thermal expansion of concrete as 10×10^{-6} per degree celcius. Maximum slab temperature in summer is 54°C. [6]
c) What are the various tests carried out on bitumen? Also mention the significance of each test. [6]

SECTION - II

- Q7)** a) Write an explanatory note on the following: [8]
i) Three controls of an airplane.
ii) Wind Rose type II for orientation of runway.
b) Explain the term Minimum Turning Radius with the help of suitable sketch. [3]
c) Differentiate between: [6]
i) Runway and Taxiway.
ii) Airport and Aerodrome.
iii) Apron and Hangars.

OR

- Q8)** a) Discuss the various factors affecting Airport Capacity. [5]
b) Explain in brief basic runway length. [4]
c) What are the points to be considered during the site selection of a Heliport. [4]
d) How Runway orientation should be done? Discuss. [4]

- Q9)** a) Give detail classification of bridges. [5]
b) Derive the equation you use to determine the Economic Span. State the assumptions also. [6]
c) Write a note on: [6]
i) Scour Depth and its effect.
ii) Importance of Free board and clearances.

OR

- Q10)** a) Sketch any 2 types of piers that are commonly used. Also label the parts. [6]
b) Explain in brief the Rational Formula to calculate the design discharge. [6]
c) Define Afflux. State and explain various formula to calculate Afflux. [5]

- Q11)** a) Enlist various types of Loads coming on a major bridge structure and briefly discuss IRC class AA loading. [6]
b) What is culvert? State their types with their suitability. [6]
c) Write a note on Maintenance of bridges. [4]

OR

- Q12)** a) Differentiate between [6]
i) Cantilever bridges and Bascule bridges.
ii) Movable span and Fixed Span bridges.
iii) Fixed bearing and Free bearing.
b) Write a detail note on the different erection methods employed during construction of bridges. [6]
c) What is cut water and Ease water? Sketch any two shapes of cut water and Ease water. [4]



Total No. of Questions : 12]

SEAT No. :

P1173

[Total No. of Pages : 3

[4164] - 20A

B.E. (Civil)

FOUNDATION ENGINEERING

(2003 Pattern) (Sem. - II)

Time :3 Hours]

[Max. Marks :100

Instructions to the candidates:-

- 1) *Answer 3 questions from each Section.*
- 2) *Answers to the two sections should be written in separate books.*
- 3) *Neat diagrams must be drawn wherever necessary.*
- 4) *Figures to the right indicate full marks.*
- 5) *Assume suitable data, if necessary.*

SECTION - I

- Q1)** a) What are the factors that affect the sample disturbance? [6]
b) State & Explain the factors on which the extent of exploration depends. [6]
c) Differentiate between SPT & DCPT. [5]

OR

- Q2)** a) Describe the standard penetration test explaining its application in foundation engineering. [6]
b) What are the objectives of soil investigation? [6]
c) Describe the chunk sampling with a neat sketch. [5]
- Q3)** a) Define the terms normal consolidation, over consolidation & preconsolidation pressure. [6]
b) Explain in brief consolidation test & enlist the consolidation parameters obtained from the test result. [6]
c) Enlist the causes of foundation settlement. [5]

P.T.O.

OR

- Q4)** a) Explain with neat sketch, square root of time fitting method to find out coefficient of consolidation. [6]
b) Explain with sketches spring analogy model in consolidation process. [6]
c) Write mathematical equation for compression index, coefficient of compressibility & coefficient of volume change. [5]
- Q5)** a) Write down assumption made in Terzaghi theory & State Terzaghi Bearing capacity equation. [6]
b) Explain with neat sketch Plate Load Test & state limitations. [6]
c) What is the ultimate bearing capacity of a rectangular footing, $1\text{ m} \times 2\text{ m}$, on the surface of saturated clay of unconfined compression strength of 100 kN/m^2 . [4]

OR

- Q6)** a) Explain with neat sketches, modes of bearing capacity failures in soil. [6]
b) Explain Housel's perimeter shear concept. [6]
c) Explain the concept of floating foundation with neat sketch. [4]

SECTION - II

- Q7)** a) With a neat sketch explain the load carrying mechanism of friction piles & end bearing piles. [6]
b) Explain classification of piles based on mode of transfer of load, method of construction & use of pile. [6]
c) Write short note on Under-reamed pile with neat sketch. [5]

OR

- Q8)** a) What are the advantages & disadvantages of pneumatic Caissons over open caissons? [6]
b) What is Caisson disease? Mention nature of symptoms observe in human being during caisson disease. [6]
c) Draw a neat sketch of well foundation showing its different components. [5]
- Q9)** a) Enlist typical ten characteristics of Black Cotton Soils & give their approximate values. [6]
b) State & explain six important recommendations for building foundation in Black Cotton Soil. [6]
c) Define swelling pressure. Enlist factors affecting the swelling pressure. [5]

OR

- Q10)**a) Explain with sketches pressure distribution behind braced sheet piles in
- i) Cohesive soils
 - ii) Cohesionless soils [6]
- b) For cantilever sheet pile, using approximate method work out depth of embedment. [6]
- c) With neat sketches enlist different types of cofferdams. [5]
- Q11)**a) Explain with sketches various functions of geosynthetics. [6]
- b) Explain with figures the constructions of nailed soil wall. [6]
 - c) Write a short note on types of geosynthetics. [4]

OR

- Q12)**a) State & explain factors affecting liquefaction of soil. [6]
- b) Explain four different types of earthquake scales used in engineering practice. [6]
 - c) Write a short note on liquefaction. [4]



Total No. of Questions : 12]

SEAT No. :

P1174

[Total No. of Pages : 7

[4164] - 21

B.E. (Mechanical)

MECHANICAL SYSTEM DESIGN

(2003 Pattern) (Sem. - I)

Time :4 Hours]

[Max. Marks :100

Instructions to the candidates:

- 1) *Answer 3 questions from Sections - I and 3 questions from Section II.*
- 2) *Answers to the two sections should be written in separate books.*
- 3) *Neat diagrams must be drawn wherever necessary.*
- 4) *Figures to the right indicate full marks.*
- 5) *Use of logarithmic tables slide rule, Mollier charts, electronic pocket calculator and steam tables is allowed.*
- 6) *Assume suitable data, if necessary.*

SECTION - I

Unit - I

- Q1)** a) With neat sketches explain different types of pressure vessel supports. [6]
- b) A high pressure cylinder consists of steel tube with inner and outer diameters of 40mm and 60mm respectively. It is jacketed by outer steel tube with an outer diameter 80mm. The tubes are assembled by shrinking process in such a way that maximum principal stress induced in any tube is limited to 150N/mm^2 . Calculate the interference pressure and original dimensions of tubes. Assume $E = 207000\text{ N/mm}^2$. [10]

OR

- Q2)** a) Explain different methods of pre-stressing a cylinder. [6]

P.T.O.

- b) A cylindrical pressure vessel of 1500mm ID is provided with a nozzle of 300mm inner diameter and 10mm thickness. Protruding lengths of nozzle inside and outside the vessel are 10mm and 40mm respectively and it is made up of seamless tube. The thickness of shell is 20mm. Internal pressure in the shell is 5MPa. The corrosion allowance is 2mm. Permissible tensile stress for shell and nozzle material is 200MPa.

Design the dimensions of reinforcing pad **if required**. The reinforcing material is of same quality as that of the shell and is available in thickness of 18mm.

(Assume weld efficiency as 90%) [10]

Unit - II

- Q3)** A tensile bar of length 600mm is subjected to constant tensile force of 4000N. If the factor of safety is 3, design the bar diameter, using Johnson's method, with the objective of minimizing material weight using optimum material from the list given in **Table 1**. [16]

Material	Density (ρ) kg/m ³	Cost (c) Rs./kg	Syt N/mm ²
Steel	7800	28	400
Aluminum alloy	2800	132	150
Titanium Alloy	4500	2200	800

Table - 1

OR

- Q4)** a) Explain the method of solving optimum design problem with redundant specifications. [12]
- b) Differentiate between optimum and adequate design. [4]

Unit - III

- Q5)** a) Derive expression for tensile stress in flywheel arm due to torque transmission. [6]
- b) Torque produced by a four stroke engine is given by $T = 4000 + 500\sin \theta + 3000 \sin 2\theta$ Nm where ' θ ' is angle turned by the crank shaft. Mean engine speed of 250 RPM is to be allowed to fluctuate by $\pm 3\%$. Load torque is constant. Design rim cross section of the flywheel made up of Wheel material is FG150 ($\rho = 7000$ kg/m³), Use factor of safety as 3. Maximum size of flywheel is limited 2m. Assume Rim width to thickness ratio as 2. Assume that rim contributes 90% of the total required inertia. [12]

OR

- Q6)** a) Derive expression for hoop stress in disc type flywheel. [6]
- b) The turning moment diagram of four stroke engine can be assumed to be consisting of four triangles. The areas measured are 800, 120, 70 and 300 mm² for power, exhaust, suction and compression strokes respectively. Scale chosen for plotting the diagram is 1 mm² = 10 J. The engine is running at 700 rpm and speed fluctuation is to be kept within 2% of mean speed. Wheel material is FG150 ($\rho = 7000 \text{ kg/m}^3$) with factor of safety as 3. The wheel diameter is limited to 1m and rim is to have rectangular cross section with width to thickness ratio of 2. Design the Flywheel if rim contributes 90% of required MI. Allowable shear stress for flywheel shaft can be taken as 50 N/mm². [12]

SECTION - II

Unit - IV

- Q7)** a) A cantilever beam is made of plain carbon steel 25C8 having the mean yield strength of 280N/mm² and a standard deviation of 40 N/mm². It is subjected to a bending stress with a mean of 180 N/mm² and a standard deviation of 20 N/mm²

Determine:

- the reliability of the beam.
- the minimum factor of safety available; and
- the average factor of safety available.

Table: - 'Areas under the standard normal distribution curve from zero to Z'.

Z	2.1	2.2	2.3	2.4	3.8	3.9
Area	0.4821	0.4861	0.4893	0.4918	0.4999	0.5000

[10]

- b) Write a short note on : Design for Powder Metallurgy. [6]

OR

- Q8)** a) The recommended class of fit for the journal and the bearing of a hydrodynamic bearing is 20 H₇e₈. The diameters of the journal and bearing are normally distributed. From the considerations of hydrodynamic action and bearing stability, the maximum and minimum clearances are limited to 0.08 and 0.05mm respectively. Determine the percentage of rejected assemblies.

The tolerances in micron are as follows:

Diameter (mm)	H ₇		e ₈	
	e _s	e _i	e _s	e _i
20	+21	0	-40	-73

Table: - Areas under the standard normal distribution curve from zero to Z.

Z	1.9	2.0	2.1	2.6	2.7	2.8
Area	0.4713	0.4772	0.4821	0.4953	0.4965	0.4974

[10]

b) Write a short note on : Design for casting.

[6]

Unit - V

Q9) A multi-speed gear box is to be designed for a machine tool for spindle speed varying between 30 r.p.m and 1000 r.p.m. If the gear box is driven by 5 kW, 720 r.p.m. electric motor through the belt drive;

- a) Draw the candidate structure diagrams.
- b) Select the optimum structure diagram.
- c) Draw speed diagram and gearing diagram.
- d) Determine the number of teeth on gears,
- e) Draw the deviation diagram

Assume same module for all gears.

[18]

OR

Q10)a) Explain with neat sketch the compound ray diagram.

[6]

b) Narrate the reasons for providing stepped regulation and not stepless variation of speeds in machine tools.

[6]

c) With the help of suitable examples, explain the importance of aesthetic considerations in the product design.

[6]

Unit - VI

Q11)a) With neat sketches, explain the different types of take-up systems used in belt conveyors. **[6]**

b) A triple ply belt conveyor is required to transport 2 ton of iron ore per hour through a distance of 1000m and a height of 300m. The permissible belt speed is 90m/min. If the mass density of iron ore is 2.5 ton per cubic metre determine,

- i) The belt width,
- ii) The diameter of drive pulley,
- iii) The reduction ratio of gear reducer, if electric motor speed is 1440 r.p.m.

Use following data:

Flow ability factor 'K' ; Belt inclination ' α '

α	10°-15°	16°-20°	21°-25°	26°-30°	31°-35°
K	2.65×10^{-4}	2.5×10^{-4}	2.35×10^{-4}	2.20×10^{-4}	2.05×10^{-4}

- Standard belt width : 400, 450, 500, 600, 650, 750, 800, 900, 1000, 1200, 1400, 1600, 1800, 2000mm
- Material factor for plies for capron belt $K_1 = 2.0$
- Belt tension and arc of contact factor $K_2 = 80$. **[10]**

OR

Q12)The following data relate to horizontal belt conveyor used in process industry.

- Belt speed = 2 m/s
- Surcharge factor for belt C = 0.0725
- Number of plies for belt = 3
- Material factor for plies K_1 = 2.0
- Belt tension and arc of contact factor for belt K_2 = 80

- Material conveying horizontal length = 260m
- Centre distance between drive pulley and tail pulley = 260m
- Centre distance between snub pulleys = 255m
- Ratio of tail pulley to drive pulley diameters = 1.0
- Ratio of snub pulley to drive pulley diameters = 0.5
- Mass of each carrying run idler = 25 kg
- Mass of each return run idler = 20 kg
- Pitch of carrying run idler = 1m
- Pitch of return run idler = 2.5 m
- Friction factor for idlers, f_c = 0.02
- Snub factor for snub pulleys ϵ_1 = 0.03
- Snub factor for drive and tail pulleys ϵ_2 = 0.06
- Material velocity along belt = 1m/s
- Capacity of conveyor = 300 mtp
- Density of material to be transported = 800 kg/m³
- Frictional resistance due to belt cleaner
near drive pulley (B = belt width, m) = 100 B, N
- Angle of lap on drive pulley = 210°
- Coefficient of friction between belt and drive pulley = 0.4
- Ultimate tensile strength for belt per
Unit length (width) of ply = 60N/mm

- Drive efficiency = 93%
- Standard belt widths:

Belt width, (mm)	500	600	750	800	900	1000	1200	1400	1600
Mass per unit length of belt, (kg/m)	7.75	9.3	11.6	12.4	14.0	15.5	18.6	21.7	24.8

- Electric motor speed = 1440 r.p.m.
 - Standard motor rating: 5, 5.5, 7.5, 10, 11, 12.5, 15, 20, 22, 25 KW.
- Determine the power required to drive the belt conveyor.

[16]



Total No. of Questions : 12]

SEAT No. :

P1175

[Total No. of Pages : 4

[4164] - 22

B.E. (Mechanical)
(Common to Mech. S/W)
DYNAMICS OF MACHINERY
(2003 Pattern) (Sem. - I)

Time :3 Hours]

[Max. Marks :100

Instructions to the candidates:-

- 1) Answer 3 questions from Section I and 3 questions from Section II.*
- 2) Neat diagrams must be drawn wherever necessary.*
- 3) Figures to the right indicate full marks.*
- 4) Assume suitable data, if necessary.*

SECTION - I

Unit - I

Q1) A four wheel car has a total mass of 3000 kg. Each wheel is of 450mm radius. The center distance between two wheels on an axle is 1.5m and wheel base is 2.5m. The height of C.G. is 0.5m above the road surface and located at 1m from front axle. Each wheel has M.I. of 32 kgm². The engine axis is along the longitudinal axis of vehicle. The engine rotates 4 times the speed of wheels in clock-wise direction when viewed from front. The mass of reciprocating parts of engine is 70 kg having radius of gyration of 100 mm. It the car is taking left turn of 70m radius at 50 km/hr. Find the ground reactions on each wheel. **[16]**

OR

- Q2)** a) Explain the terms-steering, pitching and rolling in ship. Discuss their gyroscopic effects. **[6]**
- b) A motor cyclist is travelling at 120 km/hr round a curve of 100 m radius. The motor cycle and rider have mass of 140 kg and their combined C.G. is at 0.6m from ground when motor cycle is vertical. Each wheel is of 600mm diameter and M.I. of each wheel about its axis of rotation is 1.4kgm². Engine M.I. about its axis of rotation is 0.26 kgm² and it rotates at 5 times the wheel speed in the same direction. Find the angle of inclination of the motor cycle and rider with the vertical. **[10]**

P.T.O.

Unit - II

- Q3)** a) A four cylinder vertical engine has a cranks 150mm long. The planes of rotations of the first, second and fourth cranks are 400mm, 200mm and 200mm respectively from the third crank and their reciprocating masses are 50kg, 60kg and 50kg respectively. Find the mass of the reciprocating parts for the third cylinder and the relative angular positions of the cranks in order that the engine may be in complete primary balance. [10]
- b) Explain the method of direct and reverse cranks to find unbalance forces in radial engines for primary and secondary unbalance. [6]

OR

- Q4)** a) The length of each connecting rod of a 60° V engine is 220mm and the stroke is 100mm. The mass of the reciprocating parts is 1.2kg per cylinder and the crank speed is 2400 rpm. Find the values of primary and secondary forces. [8]
- b) A three cylinder engine has its cranks spaced at equal angular interval of 120°. Each crank is 150mm long and connecting rod is 625 mm long. The pitch of the cylinders is 450mm and speed is 500 rpm. If the reciprocating parts per cylinder have a mass of 70 kg. Find the unbalanced primary and secondary effects of the reciprocating parts. [8]

Unit - III

- Q5)** a) Derive Frequency equation for simple pendulum. Neglect weight of string. [8]
- b) A disc of torsional pendulum has a moment of inertia of 600 kg-cm² and is immersed in a viscous fluid. The brass shaft attached to it is of 10cm diameter and 40 cm long. When the pendulum is vibrating. The observed amplitudes on the same side of the rest position for successive cycles are 9°, 6° and 4°. Determine
- i) Logarithmic decrement.
 - ii) Damping torque at unit velocity.
 - iii) The periodic time of vibration.

Assume $G = 4.4 \times 10^{10} \text{ N/m}^2$.

What would be the frequency if the disc is removed from the viscous fluid? [10]

OR

- Q6)** a) A U tube open to atmosphere at both ends contains a column length L of certain liquid. Find the natural period of oscillation of the liquid column. [8]
- b) Derive an expression for the motion of springmass-dashpot system in case of [10]
- i) Overdamped system.
 - ii) Underdamped system.
- Also draw displacement-time plot. for above cases.

SECTION - II

Unit - IV

- Q7)** a) A harmonic force of amplitude 200N and frequency 5Hz acts on the mass of a damped single degree of freedom system having $m = 10$ kg, $K = 2000$ N/m and $C = 50$ Ns/m. Determine the complete solution representing the motion of the mass if the initial displacement and velocity of the mass are 10 mm and 5 m/s respectively. [14]
- b) Explain the following terms: [4]
- i) Vibration Isolation.
 - ii) Force Transmissibility.

OR

- Q8)** a) An electric motor is supported on a spring and a dashpot. The spring has stiffness 5500 N/m and dashpot offers a resistance of 310N at 3.3 m/sec. The unbalanced mass 0.5 kg rotates at 60mm radius and total mass of vibratory system is 30 kg. The motor runs at 360 rpm. Determine the following: [12]
- i) Damping Factor
 - ii) Amplitude of Vibration.
 - iii) Phase Angle.
 - iv) Resonant speed.
 - v) Resonant Amplitude.
 - vi) Forces exerted by the spring and dashpot on the motor.
- b) A vehicle moves over a road surface having approximately the sinusoidal profile with a wavelength of 10m and an amplitude of 80mm. The vehicle is moving with a velocity of 55 km/hr. Calculate the critical speed of the vehicle, if the amplitude of vibration is 25mm and mass of vehicle is 500 kg. [6]

Unit - V

- Q9)** a) What do you understand by a Semi-definite or degenerate system? Give two examples of systems that are degenerate. [6]
- b) Two rotors, A and B are attached to the ends of a shaft 600mm long. The weight of the rotor A is 400N and radius of gyration is 400mm. The weight of the rotor B is 500 N and radius of gyration is 500mm. The shaft is 80mm diameter for first 250mm, 120mm for next 150mm and 100mm for the remaining length from the rotor A. Modulus of rigidity for the shaft material is 0.8×10^{11} N/M². Find:
- i) The position of the node.
 - ii) The Frequency of torsional vibrations. [10]

OR

- Q10)a)** Explain the concept of torsionally equivalent shaft. [4]
- b) An electric motor running at 1500 rpm drives a pump through gearing. Pump runs at 500 rpm. The motor armature has mass moment of inertia of 400 kgm^2 and the pump impeller has a mass moment of inertia of 1400 kg-m^2 . The motor shaft is 45 mm diameter and 180 mm long. The pump shaft is having 90mm diameter and 450mm length. Find:
- The equivalent system having a uniform shaft diameter of 45mm and running at 1500 rpm.
 - The natural frequency of the system neglecting inertia of gears.
- Take $G = 84 \times 10^9 \text{ N/m}^2$. [12]

Unit - VI

- Q11)a)** Explain the method to determine the critical speed of shaft carrying single rotor. [6]
- b) A vertical shaft of 20mm in diameter and 600mm long is held in short bearings at the ends. A 5kg disc is mounted on the shaft midway between the bearings. The CG of the disc is 0.5mm away from the axis of the shaft. If the allowable tensile stress for the shaft is 70 N/mm^2 , determine:
- The critical speed of the shaft, and
 - The range of the speed which is not safe.
- Take $E = 200 \text{ GPA}$. [10]

OR

- Q12)a)** Explain the working principles of: [8]
- Frequency measuring instruments.
 - Velocity pick-ups.
 - Vibrometers.
 - Accelerometers.
- b) For measuring the frequency of vibration of a system a Frahm's Reed Tachometer is to be designed. A mass of 0.01kg is to be placed at the end of one of the reeds so that the reed is in resonance at a frequency of 15 Hz. The steel reed is 40mm long and 3mm wide. Determine the thickness of the reed.
- Take $E = 2 \times 10^{11} \text{ N/m}^2$. [8]



Total No. of Questions : 12]

SEAT No. :

P1176

[Total No. of Pages : 3

[4164] - 23

B.E. (Mechanical)
MECHATRONICS
(2003 Pattern) (Sem. - I)

Time :3 Hours]

[Max. Marks :100

Instructions to the candidates:-

- 1) *Answer 3 questions from Section I and 3 questions from Section II.*
- 2) *Answer to the two sections should be written in separate answer books.*
- 3) *Neat diagrams must be drawn wherever necessary.*
- 4) *Use of logarithmic tables slide rule, Mollier charts, electronic pocket calculator and steam tables is allowed.*
- 5) *Assume suitable data, if necessary.*

SECTION - I

- Q1)** a) Explain with a neat sketch various components of measurement system. [5]
b) Explain the following terms:- [6]
i) Linearity ii) Hysteresis.
c) Compare the characteristics of Rotameter and Anemometer. [5]

OR

- Q2)** a) Explain with a neat sketch the working principle of Mcleod gauge. [5]
b) Compare the characteristics of any two pressure measuring devices. [5]
c) Distinguish between the following: [6]
i) Accuracy and precesion.
ii) Zero drift and sensitivity drift.

- Q3)** a) State typical LVDT specifications. [5]
b) Explain with a neat sketch the working principle of absolute optical encoder. [5]
c) Define Gauge factor and derive the expression for the same. [6]

OR

P.T.O.

- Q4)** a) Write a short notes on the following: [8]
 i) Thermocouple ii) Load cells.
 b) Explain any two level measurement devices. [4]
 c) Write a short note on Pyrometers. [4]

- Q5)** a) Explain Thermal system building blocks. [6]
 b) Explain feed back control system with suitable example. [6]
 c) Derive the model equation of a rotational mechanical system with spring mass and damper. [6]

OR

- Q6)** a) Explain Fluid system building blocks. [6]
 b) Compare open loop and closed loop control system. [6]
 c) Write a short note on: [6]
 i) Bode Plots.
 ii) Transfer function.

SECTION - II

- Q7)** a) Define Proportional, Integral and Derivative Controller with mathematical expression. [6]
 b) A controller outputs a 4 - 20 mA signal to control motor speed from 140 to 600 rpm with a linear dependence Calculate [6]
 i) current corresponding to 310 rpm, and
 ii) the value of (a) expressed as the percent of control output.
 c) Explain any one level transmitter with respect to principle of working and advantage. [4]

OR

- Q8)** a) Explain the response of first order system for step input. [4]
 b) Explain the significance of bode plots for system with $\frac{1}{s}, \frac{1}{s^2 + 2\xi\omega_n s + \omega_n^2}$ [6]
 c) Explain working of thermal transmitter with principle of working, advantages and disadvantages. [6]

- Q9)** a) Comment of Wheatstone's bridge with respect to construction, working, mathematical equation, and applications. [8]
b) Explain applications of Analog to Digital Converter. [4]
c) Explain with symbol and truth table the AND and Exclusive OR logic gates. [4]

OR

- Q10)** a) Explain Voltage divider and impedance matching with respect to analog signal conditioning techniques. [6]
b) Explain significance of filters in analog signal conditioning and its applications. [5]
c) Comment of Boolean Algebra and its use in Control Applications. [5]

- Q11)** a) Explain the components of ladder diagram used in PLC programming. [6]
b) With respect to Symbol, inputs, and outputs, explain OFF DELAYED TIMER used in PLC with one application. [6]
c) Write Ladder program for START and STOP button programming. [6]

OR

- Q12)** a) For indication, two latching NO switches are given with two lamps RED and BLUE. The objectives are [12]
i) RED lamp should be ON when SW1 is pushed and SW2 is not pushed.
ii) GREEN lamp should be ON when SW2 is pushed and SW1 is not pushed.
iii) No lamp should be ON when both the switches are pushed or not pushed.

Write a ladder program to accomplish these objectives. Write the assumptions, notations, and working of each rung.

- b) Write any three applications of counters in Industries. [6]



[4164] - 24

B.E. (Mechanical)**GAS TURBINES & JET PROPULSION****(2003 Pattern) (Sem. - I)***Time : 3 Hours]**[Max. Marks : 100**Instructions to the candidates:-*

- 1) *Answer 3 questions from Section I and 3 questions from Section II.*
- 2) *Answer to the two sections should be written in separate answer books.*
- 3) *Neat diagrams must be drawn wherever necessary.*
- 4) *Figures to the right indicate full marks.*
- 5) *Use of logarithmic tables slide rule, Mollier charts, electronic pocket calculator and steam tables is allowed.*
- 6) *Assume suitable data if necessary.*

SECTION - I**Unit - I**

- Q1)** a) What is sonic velocity? Derive the equation for it in terms of temperature of compressible flow and ratio of specific heats. [6]
- b) Define following terms: [4]
- i) Mach Number.
 - ii) Mach line.
 - iii) Mach angle.
 - iv) Mach cone.
- c) Air is flowing through a converging nozzle. At a particular point within the nozzle, the pressure P_1 is 3.5 bar, temperature T_1 is 556K, the velocity V_1 is 180 m/s. Consider air to be an ideal gas with $\gamma = 1.4$ and find the stagnation temperature T_0 and the pressure P_0 . [6]

OR

- Q2)** a) With usual notations, for the isentropic flow, the mass flow rate through throat section is given by

$$\dot{m} = A_2 \sqrt{\frac{P_1}{v_1} \cdot \frac{\gamma}{\gamma - 1} \left\{ \left(\frac{P_2}{P_1} \right)^{\frac{2}{\gamma}} - \left(\frac{P_2}{P_1} \right)^{\frac{\gamma+1}{\gamma}} \right\}} \quad [8]$$

- b) What is Fanno Flow? What are the requirements for Fanno Flow. [4]
- c) What is adiabatic process? What are the assumptions required for solutions of the equations for this process. [4]

P.T.O.

Unit - II

- Q3)** a) Compare centrifugal and axial flow compressors, in detail. [8]
- b) A centrifugal compressor delivers 12 m^3 of free air while running at 10,000 rpm. The air is compressed from 1 bar, 20°C to 4 bar with an isentropic efficiency of 81%. Blades are radial at the outlet of the impeller and the flow velocity is 60 m/s which is constant through out. The ratio of outer and inner radii of the impeller is 2 and slip factor is 0.9. The blade area coefficient at inlet is 0.92.
- Determine:
- Temperature of air discharged and.
 - Theoretical power required. [8]

OR

- Q4)** a) Derive an expression for work input to an axial flow compressor. What do you understand by work done factor? [8]
- b) Explain with the help of h-s diagram the working of axial compressor with three stages. [8]

Unit - III

- Q5)** a) Explain with a neat sketch the working of semi-closed cycle. [8]
- b) A gas turbine set having a heat exchanger, gave the following data at the design speed.

$$\eta_{\text{isen, comp}} = 80\%, \quad \eta_{\text{isen, turbine}} = 85\%$$

Pressure ratio 5:1, $\dot{m}_{\text{air}} = 20 \text{ kg/hr}$ Max. cycle temperature = 725°C .
Effectiveness of heat exchanger = 0.8. Ambient pressure and temperature = 1.013 bar and 25°C .

Determine

- Power output.
- Specific fuel consumption.
- Thermal efficiency.

Take $C_p = 1.05 \text{ kJ/kg} - \text{K}$

$$\gamma = 1.4$$

$$\text{C.V.} = 43,000 \text{ kJ/kg.} \quad [10]$$

OR

- Q6)** a) Find the condition for maximum efficiency of the Brayton cycle. What do you understand by maximum pressure ratio? Also find the condition for maximum network output of Brayton cycle. In this case, what is the pressure ratio called? Find the relation between maximum pressure ratio and the pressure ratio for maximum network. [12]
- b) What are main variables which affect the performance of the gas turbine? Explain the effect of any one such variable on the turbine performance. [6]

SECTION - II

Unit - IV

- Q7)** a) Explain with the help of enthalpy - entropy diagram the working of a reaction turbine stage. [6]
- b) Derive an expression for maximum utilization factor of a 50% reaction stage. [10]

OR

- Q8)** a) Explain open cycle gas turbine with intercooling. [6]
- b) Write notes on:- [10]
- i) Closed cycle & open cycle gas turbines.
 - ii) Energy flow diagram for a stage of an impulse turbine.

Unit - V

- Q9)** a) What are the advantages of secondary air supply in a gas turbine combustion chamber sketch the system to show how the secondary air is used. [6]
- b) Discuss the use of cermics in gas turbines. [6]
- c) Write a note on flame tube cooling. [4]

OR

- Q10)**a) What are the different types of combustion chambers that are used for gas turbines? Sketch any one combustion chamber and explain the working of the same. [8]
- b) Explain in brief:-
- i) Blade cooling of gas turbines.
 - ii) Fuels for Gas - turbines. [8]

Unit - VI

Q11)a) Explain with a neat sketch:

i) Ramjet

ii) Pulse jet.

[10]

b) What is thrust augmentation? Explain how it can be achieved.

[8]

OR

Q12)a) A twin-jet turbojet system is used on an aeroplane flying at 260m/s. The density of air at the attitude is 0.18 kg/m^3 . Drag on the plane 7000N & the propulsion efficiency is 60 percent.

Calculate:-

[12]

i) diameter of jets.

ii) fuel consumption per thrust kW-hour.

iii) air - fuel ratio of the engines.

The over all plant efficiency is 18% and calorific value of the fuel used is 48000kJ/kg. Neglect any losses in the jet nozzles.

b) Write a note on nuclear rockets.

[6]



Total No. of Questions : 12]

SEAT No. :

P1178

[Total No. of Pages : 2

[4164] - 25

B.E. (Mechanical)

PRODUCT DESIGN & DEVELOPMENT

(2003 Pattern) (Elective - I) (Sem. - I)

Time :3 Hours]

[Max. Marks :100

Instructions to the candidates:-

- 1) *Answer any 3 questions from each section.*
- 2) *Answers to the two sections should be written in separate books.*
- 3) *Neat diagrams must be drawn wherever necessary.*
- 4) *Figures to the right indicate full marks.*

SECTION - I

Unit - I

- Q1)** a) Explain product development verses product design. [8]
b) Explain the role of product development team in detail. [8]

OR

- Q2)** Why it is important to understand customer needs? Discuss various types of needs in detail. Explain any two methods of gathering customer needs in detail. [16]

Unit - II

- Q3)** a) Discuss the process of product tear down stepwise. [9]
b) What is subtract & operate procedure? Elaborate with suitable example.[8]

OR

- Q4)** a) Explain the benchmarking approach in product design. [9]
b) Explain product based modularity & manufacturing based modularity.[8]

Unit - III

- Q5)** a) Discuss traditional brainstorming & memory maps in concept generation. [9]
b) Explain morphological analysis in detail. [8]

P.T.O.

OR

- Q6)** a) Explain pughs concept selection chart with example. [9]
b) Discuss failure Modes & Effects Analysis in detail. [8]

SECTION - II

Unit - IV

- Q7)** a) Explain the guidelines for design for environment. [8]
b) What are environmental objectives? Discuss global & local issues related to pollution & environment. [8]

OR

- Q8)** a) Discuss the guidelines for design for manufacture. [8]
b) Discuss in detail piece part production. [8]

Unit - V

- Q9)** a) Explain the fundamental concepts in optimization as constraints & objective function in detail with suitable example. Discuss various types of constraints. [9]
b) Discuss Linear programming & sequential quadratic programming. [8]

OR

- Q10)**a) Discuss global optimality & sensitivity analysis. [9]
b) Explain pareto optimality & stopping criteria in detail. [8]

Unit - VI

- Q11)**a) Discuss various types of Prototypes. [9]
b) What is rapid prototyping? Explain any one method in detail. [8]

OR

- Q12)**a) Explain the concept of design of experiments in detail. [9]
b) Discuss Quality design theory in detail. [8]



Total No. of Questions : 12]

SEAT No. :

P1179

[Total No. of Pages : 3

[4164] - 27

B.E. (Mechanical)

ALTERNATIVE ENERGY SOURCES

(Elective - I) (2003 Pattern) (Sem. - I)

Time : 3 Hours]

[Max. Marks : 100

Instructions to the candidates:-

- 1) *Answer Q.1 or Q.2, Q.3 or Q.4 and Q.5 or Q.6 in Section - I and Q.7 or Q.8, Q.9 or Q.10 and Q.11 or Q.12 in Section - II.*
- 2) *Answer 3 questions from Section - I and 3 questions from Section - II.*
- 3) *Answers to the two sections should be written in separate answer books.*
- 4) *Use of logarithmic tables slide rule, Mollier charts, electronic pocket calculator and steam tables is allowed.*
- 5) *Figures to the right indicate full marks.*
- 6) *Assume suitable data if necessary.*
- 7) *Neat diagrams must be drawn wherever necessary.*

SECTION - I

- Q1)** a) State second law of thermodynamics and discuss its practical importance. [4]
b) Write in brief indirect applications of solar energy utilizations. [6]
c) Calculate the day length on May 02 and December 01 on a surface facing due south at an angle of 40° to horizontal and at a place ($19^\circ 07'N$, $72^\circ 30' E$). [6]

OR

- Q2)** a) Define the following: [8]
i) Declination, ii) Hour angle,
iii) Day length, iv) Zenith angle.
b) With the help of neat sketch explain the working of pyranometer for measurement of beam and diffused radiations. [8]
- Q3)** a) State various types of solar collectors indicating their temperature range of working and their application. [6]
b) Write short note on [12]
i) Instantaneous collection efficiency,
ii) Collector aperture area and gross area.
iii) Stagnation temperature and its use.

P.T.O.

OR

- Q4)** a) Explain solar passive space heating and cooling with neat sketches. [6]
b) Write a note on novel designs of solar air heaters. [6]
c) How the cost of solar water heating system can be assessed based on its life cycle period. [6]

- Q5)** a) Explain the working of paraboloid dish collector system with its advantages and disadvantages. [6]
b) Write a note on heliostat. [6]
c) Write advantages and disadvantages of concentrating collector over flat plate collector. [4]

OR

- Q6)** a) Write a note on different types of solar stills and their uses. [8]
b) Explain how solar ponds are used for solar energy collection and also write its advantage and disadvantages. [8]

SECTION - II

- Q7)** a) Explain the principle of photovoltaic conversion in a PV cell. What materials are used in PV cells? [8]
b) State various types of windmills and explain any one type with neat sketch. [8]

OR

- Q8)** a) State different types of solar thermal power plants and explain high temperature solar power generation. [10]
b) Discuss the prospects of wind energy in India as a non conventional energy source. [6]

- Q9)** a) Explain working principle of fuel cell and state its limitations. [8]
b) Give suitable locations for geothermal power plant in India. What are limitations & applications of geothermal energy. [8]

OR

- Q10)** a) Explain with neat sketch a closed cycle OTEC system. [8]
b) Discuss the prospects of Tidal energy in India. Write suitable locations for the same. [8]

- Q11)**a) What is biogas? Why are biogas plants important in Indian context. [8]
b) Explain two types of gasifier systems with neat sketch. [10]

OR

Q12) Write Notes on any three. [18]

- a) Environment protection Norms ISO - 14000.
- b) Biogas for diesel engine.
- c) Floating Dome type biogas plant.
- d) Bio mass gasification.



Total No. of Questions : 12]

SEAT No. :

P1180

[Total No. of Pages : 3

[4164] - 28

B.E. (Mechanical)

KINEMATIC ANALYSIS AND SYNTHESIS

(2003 Pattern) (Elective - I) (Sem. - I)

Time : 3 Hours]

[Max. Marks : 100

Instructions to the candidates:-

- 1) *Answer three questions from Section I and three questions from Section II.*
- 2) *Answers to the two sections should be written in separate answer books.*
- 3) *Neat diagrams must be drawn wherever necessary.*
- 4) *Figures to the right indicate full marks.*
- 5) *Use of logarithmic tables, slide rules and electronic pocket calculator is allowed.*
- 6) *Assume suitable data, if necessary.*

SECTION - I

- Q1)** a) Explain Grubler criterion for spatial mechanism and reduce the form to apply for planer mechanism. [8]
- b) Explain various types of linkages and mechanism for different practical applications. [8]

OR

- Q2)** a) Explain the term 'Mechanical Advantage' and 'Transmission Angle' with reference to a four bar mechanism. Obtain an expression for the mechanical advantage, stating the assumption made if any. [10]
- b) Explain equivalent linkage concept with examples. [6]
- Q3)** a) Explain with neat sketches how the auxiliary point method can be applied to a mechanism with low degree of complexity by taking an example. [8]
- b) In a four link mechanism, the dimensions of the link are as under. AB = 50 mm, BC = 66 mm, CD = 56 mm and AD = 100mm. AD is a fixed link. At an instant when angle DAB is 60° , the angular velocity of the input link AB is 10 rad / s in the counterclockwise direction with an angular retardation of $25 \text{ rad} / \text{s}^2$. Determine analytically the angular displacement, angular velocities and angular acceleration of the coupler link BC and output link DC. [8]

P.T.O.

OR

- Q4)** a) State and explain Freudenstein's theorem. [6]
b) Explain the complex algebra method for displacement, velocity and acceleration analysis of a crank and slotted lever quick return mechanism. Explain how the resulting equations are solved. [10]

- Q5)** a) Write a note on Ball's point and its use in dwell linkage synthesis. [6]
b) A slider crank mechanism with zero offset has crank length 20 mm, connecting rod length 60 mm. Crank makes 35° with IDC. Use Bobillier construction to draw the inflection circle. Then find the radius of curvature of the midpoint of the connecting rod. [12]

OR

- Q6)** a) State any two forms of Euler - Savary Equation and discuss their significance and uses with reference to the rolling motion of the moving centrode over the fixed centrode. [9]
b) Explain how curvature theory is used in synthesizing dwell linkages to replace Cam - follower mechanism. [9]

SECTION - II

- Q7)** a) Write short notes on (Any two) [8]
i) Function generation
ii) Path generation
iii) Branch and Order defect.
b) Describe a graphical method to synthesize a crank and rocker mechanism when two successive rotations θ_{12} and θ_{23} of the crank are to be coordinated with two successive rotations ϕ_{12} and ϕ_{23} of the rocker. [8]

OR

- Q8)** Using freudenstein equation, design a four bar mechanism to generate the function $y = x^{1.4}$ for an interval in x from 1 to 4. The input link is to start from 30° and is to have a range of 90° , the output link is to start from 90° and is to have a range of 90° . Use three point chebychev spacing. Take the length of fixed link AD as 50 mm. [16]

- Q9) a)** State and prove Robert - Chebychev theorem. [6]
b) Using complex number method, synthesis a four bar linkages that satisfies following specifications in one of its position.
 $\omega_1 = 8 \text{ rad / s}$, $\omega_2 = 1 \text{ rad / s}$, $\omega_3 = -3 \text{ rad / s}$ and
 $\alpha_1 = 0 \text{ rad / s}^2$, $\alpha_2 = 20 \text{ rad / s}^2$, $\alpha_3 = 0 \text{ rad / s}^2$. [10]

OR

- Q10)a)** Explain double point and Symmetry of a Coupler curve. [6]
b) Determine the link lengths of a four bar linkage using Freudenstein's equation that satisfies following specifications in one of its position.
 $\theta_2 = 60^\circ$, $\omega_2 = 5 \text{ rad / s}$, $\alpha_2 = 2 \text{ rad / s}^2$.
 $\theta_4 = 90^\circ$, $\omega_4 = 2 \text{ rad / s}$, $\alpha_4 = 7 \text{ rad / s}^2$. [10]

- Q11)a)** Write short note on Eulerian Angles. [8]
b) Obtain an expression for the transformation matrix relating two Cartesian frames which are translated and rotated with respect to each other. [10]

OR

- Q12)a)** Write short note on Denavit - Hartenberg parameters. [9]
b) Explain transformation matrix method of displacement analysis of spatial mechanisms. Obtain displacement relationship for Hooke's Joint. [9]



Total No. of Questions : 12]

SEAT No. :

P1181

[Total No. of Pages : 7

[4164] - 29

B.E. (Mechanical)

OPERATION RESEARCH

(2003 Pattern) (Elective - I) (Sem. - I)

Time :3 Hours]

[Max. Marks :100

Instructions to the candidates:

- 1) *Answer 3 questions from Section - I and 3 questions from Section - II.*
- 2) *Answers to the two sections should be written in separate books.*
- 3) *Neat diagrams must be drawn wherever necessary.*
- 4) *Figures to the right indicate full marks.*
- 5) *Use of logarithmic tables slide rule, Mollier charts, electronic pocket calculator and steam tables is allowed.*
- 6) *Assume suitable data, if necessary.*

SECTION - I

- Q1)** a) Definition of operation research (any two) **[4]**
- b) Define Slack, Surplus and artificial variables. **[6]**
- c) Solve the L.P. problem graphically. **[8]**

$$\text{Max } Z = 2x_1 + 3x_2$$

Subjected to:

$$x_1 + x_2 \leq 30$$

$$x_2 \geq 3$$

$$x_2 \leq 12$$

$$x_1 - x_2 \geq 0$$

$$x_1 \leq 20$$

$$x_1, x_2 \geq 0$$

OR

P.T.O.

- Q2) a)** Define linear programming. Give applications of linear programming. **[6]**
- b) A toy manufacturing company has two types of dolls, a basic version (A) and deluxe version (B). Each doll of types B takes twice as long as one of types A and the company would have time to make maximum of 2000 dolls per day. Supply of plastic is sufficient to produce 1500 dolls per day for both (A) and (B) combined. The deluxe version doll B requires a fancy dress of which there are 600 dresses per day available. If company makes a profit of Rs. 3 and Rs. 5 per doll of type A and B respectively, how many dolls of types A and B to be produced to maximize the profit. Solve by Simplex method. **[12]**

- Q3) a)** Explain VAM method to solve transportation problem. **[6]**
- b) A product is produced by four factories A, B, C, and D. The unit production cost are Rs. 2, Rs. 3, Rs. 1 and Rs. 5 respectively. Their production capacities are factory A - 50 units B - 70 units C - 30 units D - 50 units. These factories supply the product to four stores demands of which are 25, 35, 105 and 20 units respectively. Unit transportation cost in Rupees from each factory to each store is given in table 1. Determine the extent of deliveries from each of factories to each of stores, so that total production and transportation cost is minimum. **[10]**

Table 1

Factories	Stores			
	1	2	3	4
A	2	4	6	11
B	10	8	7	5
C	13	3	9	12
D	4	6	8	3

OR

- Q4) a)** Explain the Hungarian method of solving assignment problems. **[8]**
- b) Four lecturers each capable teaching any one of the four different subjects. Class preparation time in hours for different subject varies from teachers to teachers and is given in table 2. Each lecturer is assigned only one subject. Determine an assignment schedule, so as to minimize the total subject preparation time for all subjects. **[8]**

Table 2

Teachers	Subjects			
	ATD	MD	PE	OR
A	2	10	9	7
B	15	4	14	8
C	13	14	16	11

Q5) a) A manufacturer uses Rs. 10,000 worth of an item during the year. He has estimated the ordering costs as Rs. 25 per order and carrying cost as 12.5% of average inventory. Find the optimal order size, number of orders per year, time period per order and total cost. **[8]**

b) Explain the price discount inventory model with instantaneous supply with no shortage. **[8]**

OR

Q6) a) Derive the expression for EOQ. **[6]**

b) Write short notes on integer programming and dynamic programming. **[10]**

SECTION - II

Q7) a) Explain the arithmetic method of solving game theory problems. **[8]**

b) Reduce the following game (Table 3) by dominances and find the value of the game. **[10]**

Table 3

Company Strategies	Union Strategies			
	I	II	III	IV
I	20	15	12	35
II	25	14	8	10
III	40	2	19	5
IV	5	4	11	0

OR

- Q8) a)** The cost of an equipment is Rs. 62000 and its scrap value is Rs. 2000/-. The life of the equipments is 8 years. The maintenance costs for each year are given in table 4. **[8]**

Table 4

Years	1	2	3	4	5	6	7	8
Maintenance in Rs.	1000	2000	3500	5000	8000	10000	16000	24000

- b) Explain how the theory of replacement is used in following cases. **[10]**
- i) Replacement of item whose maintenance cost varies with time.
 - ii) Replacement of items that fail suddenly.

- Q9) a)** Explain the following elements of queuing system. **[6]**

- i) Input or arrival distribution.
 - ii) Output or departure distribution.
 - iii) Service channel.
 - iv) Service discipline.
- b) Arrival rate of telephone calls at a telephone booth is according to Poisson distribution with an average time of 9 minutes between two consecutive arrivals. The length of telephone call is assumed to be exponentially distributed with mean of 3 min. **[10]**
- i) Determine the probability that a person arriving at a booth will have to wait.
 - ii) Find the average queue length formed from time to time.
 - iii) What is the probability that arrival will have to wait for more than 10 min before phone is free.
 - iv) What is the probability that he will have to wait for more than 10 minutes before the phone is available and the call is also complete.
 - v) What is the fraction of day that the phone will be in use.

OR

- Q10)a)** What are the assumption in sequencing model. **[4]**
- b) Explain the procedure of solving sequencing problem with n jobs through two machines. **[4]**
- c) Find the sequence that minimizes the total elapsed time (in hrs) required to complete the following jobs (table 5) on three machines M1, M2 and M3 in order $M1 \rightarrow M2 \rightarrow M3$. **[8]**

Table 5

Machine	Jobs				
	A	B	C	D	E
M1	6	8	7	10	6
M2	3	2	5	6	4
M3	4	8	6	7	8

- Q11)a)** Differentiate between PERT and CPM. **[6]**
- b) A project schedule has the following characteristic (table 6) **[10]**
- i) Construct the network.
 - ii) Find critical path.
 - iii) Find total float for all activities.

Table 6

Activity	Time (Weeks)	Activity	Times
1-2	4	5-6	4
1-3	1	5-7	8
2-4	1	6-8	1
3-4	1	7-8	2
3-5	6	8-10	5
4-9	5	9-10	7

OR

Q12)a) What is resources scheduling and resources leveling with respect to project management. **[6]**

b) The small project consist of 7 activities (in days) is given in table 7**[10]**

Table 7

Activity	Estimated duration in days		
	Optimistic	Most likely	Pessimistic
1-2	6	9	18
1-3	5	8	17
2-4	4	7	22
2-5	4	7	10
3-4	1	7	18
3-5	2	5	8
4-5	4	10	22

- i) Draw the network.
- ii) Find expected duration and variance for each activity.
- iii) The probability of completion of project in 32 days.
- iv) The project duration.
- v) Critical path.



Total No. of Questions : 12]

SEAT No. :

P1182

[Total No. of Pages : 4

[4164] - 31

B.E. (Mechanical) (Common to mech. S/W)

CAD/CAM AND AUTOMATION

(2003 Pattern) (Sem. - II)

Time : 3 Hours]

[Max. Marks : 100

Instructions to the candidates:-

- 1) *Answer 3 questions from each section.*
- 2) *Answers to the two sections should be written in separate books.*
- 3) *Neat diagrams must be drawn wherever necessary.*
- 4) *Figures to the right indicate full marks.*
- 5) *Use of non-programmable electronic calculator is allowed.*
- 6) *Assume suitable data, if necessary.*

SECTION - I

- Q1)** a) Given a point $P = (6, 7, -2)$ & using the homogeneous representation calculate P^* if P is translated by $d = i + 3j - 4k$ & then scaled uniformly by $s = 1.5$. [6]
- b) What is geometric mapping? What are the different applications of it? [5]
- c) Explain translational and rotational mapping with suitable examples. [5]

OR

- Q2)** a) What is the significance of homogeneous co-ordinates in geometric transformations? [6]
- b) Derive the concatenated transformation matrix for mirroring about line $y = mx + c$. [10]
- Q3)** a) What is parametric representation of a curve? State its advantages. [4]
- b) The end points for line $L1$ are $P1 (2, 3, 5)$ and $P2(-4, 6, 2)$. The end points for line $L2$ are $P3 (-5, 8, 9)$ and $P4 (1, -11, 2)$. [8]
- i) Find parametric equation of the lines.
 - ii) Are the two lines parallel or perpendicular?
 - iii) Find the coordinates of the intersecting point.
- c) Derive the equation for parametric equation of a circle. [4]

P.T.O.

OR

- Q4)** a) Write a note on B-Spline and Bezier Curve. [8]
b) Distinguish between synthetic curves and analytical curves. [4]
c) Explain the following term with respect to surface modeling. [4]
i) Tabulated surface.
ii) Revolved surface.

- Q5)** a) For a 3 bar truss shown in Fig. 1, find nodal displacements, support reactions and elemental stresses. Cross sectional area of each element is 1000 mm^2 . Take $E = 200 \text{ GPa}$. [10]

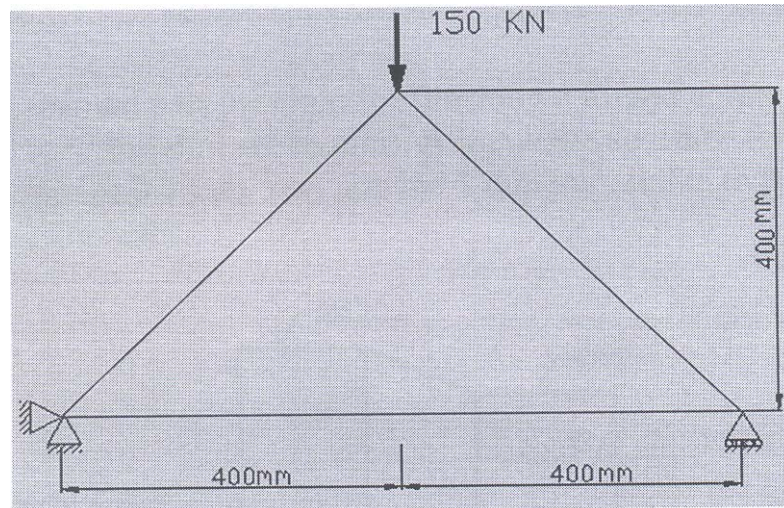

Fig. 1

- b) Explain with suitable examples the plane stress and plane strain conditions. [8]

OR

- Q6)** a) Derive an expression for the element stiffness matrix of two noded truss element. Also show element stress calculations. [10]
b) What are the properties of stiffness matrix? [4]
c) Write a note on linear shape function for 1 D element. [4]

SECTION - II

- Q7)** a) A constant strain triangle element is defined by three nodes at (2.6, 1), (8.8, 6) & (5, 9). Evaluate the shape functions N_1 , N_2 & N_3 at the interior point $P(5.5, 4)$. Also determine the Jacobian of the transformation J . [8]
b) Write a short note on Isoparametric Elements? [8]

OR

- Q8) a)** Explain, how following problems are modeled & solved. [8]
- Cylinder subjected to internal pressure.
 - Infinite cylinder with external pressure.
 - Press fit of a ring on a rigid shaft.
 - Press fit of elastic sleeve on an elastic shaft.
- b) Explain shape function of CST element. Also explain the physical representation by area coordinates. [8]

- Q9) a)** Write a manual part program for finishing a forged components as shown in the Fig. 2 (all dim are in mm). Assume the speed & feed on the turning center as 550 rpm & 0.3 mm/rev. assume 1 mm material is to be removed radially from external diameter. [8]

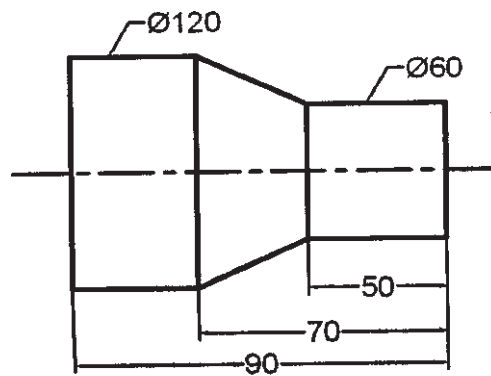

Fig. 2

- b) Compare NC, CNC & DNC. What are the advantages of combining CNC & DNC? [8]

OR

- Q10) a)** What are various activities of a manufacturing plant which can be carried out through computer control? [4]
- b) What is a canned cycle? Explain with suitable example. [4]
- c) Write a manual part program for turning a raw bar of Φ 62mm & 60 mm long as per the drawing using canned cycles. [8]

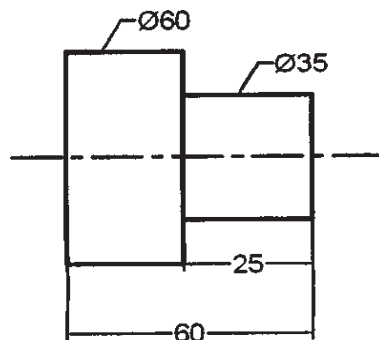

Fig. 3

- Q11)**a) What is a FMS? How does FMS ensure flexibility in manufacturing?[6]
b) Briefly describe significant application area of Robot. [6]
c) Write a short note on Types of Mechanisms for Gripper. [6]

OR

- Q12)**a) What are the Advantages & Limitations of Automation? [6]
b) Write a short note on Robot Programming. [6]
c) What are the different types of drives used in Robot? [6]



Total No. of Questions : 12]

SEAT No. :

P1183

[Total No. of Pages : 4

[4164] - 32

B.E. (Mechanical)

POWER PLANT ENGINEERING

(2003 Pattern) (Sem. - II)

Time :3 Hours]

[Max. Marks :100

Instructions to the candidates:-

- 1) *Answer 3 questions from Section I and 3 questions from Section II.*
- 2) *Answers to the two sections should be written in separate books.*
- 3) *Neat diagrams must be drawn wherever necessary.*
- 4) *Figures to the right indicate full marks.*
- 5) *Use of logarithmic tables slide rule, Mollier charts, electronic pocket calculator and steam tables is allowed.*
- 6) *Assume suitable data, if necessary.*

SECTION - I

Unit - I

- Q1)** a) Write a note on present status of power generation in India. [6]
- b) Give a comparison between gas turbine and steam power plant on the basis of site, initial cost, fuel cost, maintenance cost, cooling water requirement and reliability. [6]
- c) How hydroelectric power plants are classified? Draw layout of hydroelectric plant in general. [4]

OR

- Q2)** a) With the help of a neat sketch explain the working of pressurised water reactor (PWR). [6]
- b) What considerations have to be kept in mind while siting a nuclear power plant? [5]
- c) Write a note on nuclear waste disposal. [5]

P.T.O.

Unit - II

- Q3)** a) What do you understand by coal beneficiation. Explain. [5]
b) Discuss the principle of operation of overfeed and underfeed stokers with the help of simple diagrams. [6]
c) What do you understand by a word 'Draught'? How draughts are classified? [5]

OR

- Q4)** a) Discuss different arrangements of burners in a pulverised coal-fired furnace. [8]
b) Write short notes on: (any two) [8]
i) Coal - oil mixture (COM).
ii) Fluidized Bed combustion.
iii) Cyclone separator.

Unit - III

- Q5)** a) With a neat sketch explain Velox boiler. What are its advantages? [6]
b) A steam power plant operating on the ideal regenerative Rankine cycle with one open feed water heater. Steam enters the turbine at 150 bar and 600°C and is condensed at a pressure of 10 kPa. Steam is bled at 12 bar and enters the open feed water heater. Determine the fraction steam extracted from the turbine and thermal efficiency of the cycle and specific steam consumption. Consider pump work, use steam tables only.
Take $C_{pu} = 2.1$ kJ/kgk. [12]

OR

- Q6)** a) What are the basic requirements of insulating materials used for steam piping? Specify the insulating materials. What do you understand by economic thickness of insulation. [8]
b) A steam power plant operates between a boiler pressure of 42 bar and condenser pressure of 0.035 bar. The steam is super heated to 500°C. Calculate cycle efficiency and specific steam consumption if reheat is included. Assume that steam is just dry saturated on leaving the first turbine and is reheated to its initial temperature. Neglect pump work. [10]

SECTION - II

Unit - IV

- Q7)** a) Explain why a subsonic nozzle is convergent while a supersonic nozzle is divergent. [4]
- b) A nozzle is supplied with dry saturated steam at 12bar and back pressure 1 bar. Whether the nozzle is convergent or divergent? Calculate the throat and exit diameters if it discharges 0.25 kg/s steam. Use steam tables only. [12]

OR

- Q8)** a) In a surface condenser the pressure of steam is 0.12 bar. The rate of cooling water flow is 40 kg/kg of steam condensed. Condensate leaves at 44°C and rise in temperature of circulating water is 13°C. What is the dryness fraction of steam entering the condenser. [6]
- b) Distinguish clearly between surface condenser and jet condenser. [6]
- c) What is vacuum efficiency of condenser? What are the factors that influence the vacuum efficiency? Explain. [4]

Unit - V

- Q9)** a) Steam leaves the nozzles of De-laval turbine with a velocity of 1160 m/s. The nozzle angle is 20°. The blades are symmetrical with an angle of 30°. If the blade velocity co-efficient is 0.8 and mechanical efficiency is 0.9 calculate
- i) speed of rotation if the rotor diameter is 0.75m.
 - ii) specific steam consumption.
 - iii) blade efficiency and
 - iv) axial thrust. [10]
- b) Write notes on any two. [8]
- i) Bypass governing of steam turbine.
 - ii) Reheat factor.
 - iii) Losses in the turbine.

OR

- Q10)**a) Prove that for reaction turbine if the degree of reaction is 50%, blades are symmetrical. [10]
- b) Why compounding is necessary for the impulse turbine? Explain velocity compounding. [5]
- c) How leakage of steam is prevented in the turbine? Explain. [3]

Unit - VI

- Q11)**a) What are base load and peak load power plants? Explain. [6]
- b) Explain why incremental rate curve intersect the heat rate curve at the lowest value of heat rate. [6]
- c) What do you mean by power plant economics? Explain fixed costs and operating costs of a power plant. [4]

OR

- Q12)**a) The incremental fuel cost for two generating units A and B of a power plant are given by following relations.

$$\frac{dF_A}{dP_A} = 0.06 P_A + 11.4$$

$$\frac{dF_B}{dP_B} = 0.07 P_B + 10.$$

Where P is power in MW and F is the fuel cost in Rs/hr. Determine the economic loading of two units when total load to be supplied by the power plant is 150 MW. [8]

- b) Define and explain: load factor, diversity factor, plant use factor and capacity factor. [8]



Total No. of Questions : 12]

SEAT No. :

P1184

[Total No. of Pages : 4

[4164] - 33

B.E. (Mechanical)

INDUSTRIAL FLUID POWER

(2003 Pattern) (Sem. - II)

Time :3 Hours]

[Max. Marks :100

Instructions to the candidates:-

- 1) All questions are compulsory.*
- 2) Options are given within the set of sub-questions.*
- 3) Neat diagrams must be drawn wherever necessary.*
- 4) Assume suitable data, if necessary.*
- 5) Use of pocket non programmable electronic calculator is allowed.*

SECTION - I

- Q1)** a) Explain the advantages of fluid power system over other systems. [6]
b) Explain desirable properties of hydraulic fluid. [6]
c) Write short note on 'Heat Exchangers' used in hydraulic systems. [6]

OR

- Q2)** a) What are the functions of reservoirs? Draw a neat sketch of standard reservoir by showing it's internal and external features. [6]
b) What are additives & inhibitors used in hydraulic fluid? [6]
c) Explain with the help of graphs, the effect of temperature and pressure on hydraulic fluids. [6]

- Q3)** a) What are the most important factors one should consider while selecting a hydraulic pumps for specific application? [6]
b) Compare characteristics of different types of accumulators. [6]
c) What are various efficiencies of a pump? [4]

OR

P.T.O.

- Q4)** a) A pump has displacement volume of 96.57 cm^3 . It delivers $0.00187 \text{ m}^3/\text{s}$ of oil at 950 rpm and 72 bar pressure. If the prime mover input torque is 120 N m, what is the theoretical torque required to operate the pump? What is the mechanical, volumetric and overall efficiency of the pump? [8]
- b) Explain working of axial plunger pumps used in hydraulic system with its characteristics. [8]

- Q5)** a) Explain with neat sketch working of a counterbalance valve and draw a circuit showing it's application. [8]
- b) Compare the advantages & disadvantages of meter-in & meter-out flow control valves. [8]

OR

- Q6)** a) Draw a neat sketch and explain the working of a sequence valve. [8]
- b) Discuss the various applications of pilot operated check valves. [8]

SECTION - II

- Q7)** a) What is the purpose of providing cushioning in cylinder? With the help of neat sketch explain how it is achieved. [8]
- b) Draw and explain a pneumatic circuit using symbols, showing how to obtain two different pressures in a circuit with suitable example. [8]

OR

- Q8)** a) Define displacement of hydraulic motor. What is the effect of varying a motor's displacement on speed and torque? What factors will you consider in selecting a hydraulic motor? [8]
- b) Draw and explain a circuit, using symbols in which a hydraulic motor is used in conjunction with hydraulic cylinder. [8]

- Q9)** Write note on any three [18]
- a) Selection criterion for compressor.
- b) FRL Unit.
- c) Fluid conditioners.
- d) Air drier.

OR

- Q10)a)** What is 'shuttle valve' and 'two pressure valve'? Draw circuits using these valves. [6]
- b) Draw neat sketch of a typical 5 way 2 position directional control valve used in pneumatic control circuit. Explain its working in short. [6]
- c) Sketch cross-sectional view of double acting pneumatic cylinder and name different parts with functional and constructional details. [6]

- Q11)a)** Design the pressure parameter sequence circuit to move a 4525 N clamping frame and then impose an additional 9475 N force to hold an aluminum part with clamping cylinder and then insert alignment pin into it, with the arbor cylinder which requires 16 kN of force during extension and 4 kN of force during retraction. Both cylinders used in this circuit have a 50 mm diameter piston and 20 mm diameter rod. Maximum extension speed of cylinder is limited to 30 m/min.

Draw circuit which fulfils these requirements. Mention the rating of pump and rating and setting of pressure control valves used in this circuit. [12]

- b) Analyze the circuit shown in fig 1. [4]

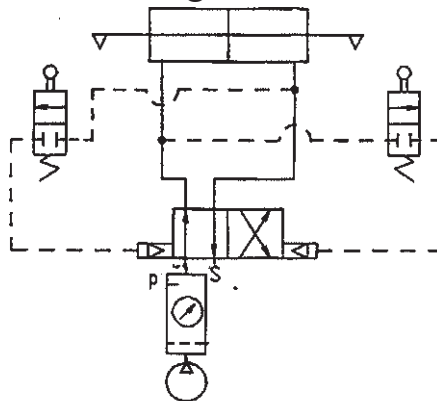

Fig. 1

OR

- Q12)a)** Design hydraulic circuit with two stage speed control during extension using meter out flow control. Initial extension of 500 mm of piston at a speed of 100 mm/s against a load of 12 kN, which is followed by 100 mm advance at 20 mm/s against a total load of 55 kN. Assuming uniform retraction against a load of 12 kN and maximum pressure drop across the flow control valve is 500 kPa.

Draw circuit which fulfils these requirements using double acting hydraulic cylinder having 50 mm diameter piston and 20 mm diameter rod. Calculate.

[10]

- i) Maximum pressure required during extension of cylinder.
 - ii) Maximum pressure required during retraction of cylinder.
 - iii) Maximum flow capacity of pump in Lit/min.
 - iv) Maximum speed of retraction in m/min.
- b) Analyze the circuit shown in fig 2. [6]

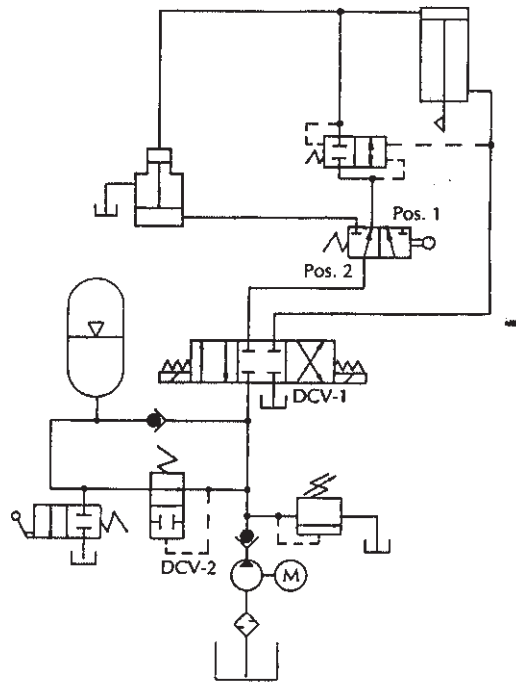

Fig. 2



Total No. of Questions : 12]

SEAT No. :

P1185

[Total No. of Pages : 3

[4164] - 34

B.E. (Mechanical)

ROBOTICS

(Elective - II) (Sem. - II) (2003 Pattern)

Time :3 Hours]

[Max. Marks :100

Instructions to the candidates:

- 1) *Answer three questions from Section - I and three questions from Section - II.*
- 2) *Answers to the two sections should be written in separate books.*
- 3) *Neat diagrams must be drawn wherever necessary.*
- 4) *Figures to the right indicate full marks.*
- 5) *Use of logarithmic tables, slide rule, Mollier charts, electronic pocket calculator is allowed.*

SECTION - I

- Q1)** a) Explain the relation between industrial automation and robotics. [6]
b) Explain difference between accuracy and repeatability. [6]
c) Write transformation matrix between {X Y Z} and {UVW} if the angle between X and U, and Y and V is 45° and between Z and W is 0° . Origin of {UVW} has x, y, z co-ordinates 25, 50 and 35 respectively. [6]

OR

- Q2)** a) Explain Denavit - Hartenberg parameters used in robot kinematics. Write its limitations. Also write its physical significance. [10]
b) Explain composite rotation matrix with suitable example. [8]
- Q3)** a) Explain how to apply forward kinematics to Cartesian configurations to determine orientation and position of end effectors. [10]
b) A 2R manipulator has $l_1 = 150$, $l_2 = 55$. It is required to reach point (60, 70). State whether the point is reachable. If not, what may be done to reach the point? [6]

OR

P.T.O.

- Q4)** a) Write note on [8]
- i) robot workspace,
 - ii) redundant degree of freedom.
- b) A planar manipulator shown in following figure is required to move in a straight line from (170, 0) to (110, 55) in 5 seconds. Determine third degree polynomial equation for its rotary joint. [8]

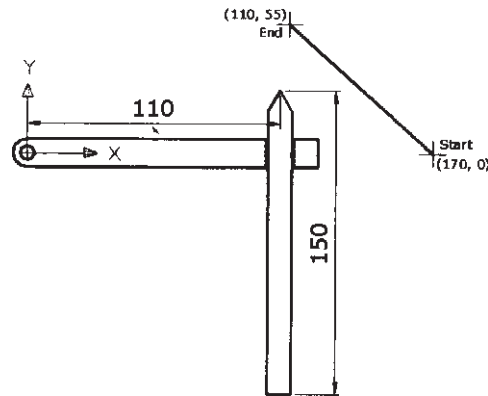

- Q5)** a) Explain the steps in trajectory planning. [6]
- b) A rotary arm of a manipulator is to rotate from 23° to 117° in 9 seconds. Determine the coefficients of cubic polynomial to interpolate a smooth trajectory. Plot the position, velocity and acceleration variation against time. [10]

OR

- Q6)** a) Write a note on force sensing wrist. [6]
- b) Write a note on manipulator control of a single joint. [6]
- c) Differentiate between path and trajectory planning. [4]

SECTION - II

- Q7)** a) Explain hydraulic grippers, with reference to the principle, use and applications. [6]
- b) Discuss various considerations for selection of a gripper. [6]
- c) Explain need for sensors and vision system in the working and control of a robot. [6]

OR

- Q8)** a) Write short note on, Characteristics of sensing devices. [6]
b) What is compliance? Explain active and passive compliance in brief.[6]
c) A vacuum gripper is used to lift flat steel plate of dimensions 10mm × 500mm × 700mm. The gripper uses to suction cups, 120 mm in diameter each, and they are located 400 mm apart for stability. Assume a factor of safety of 1.7 to allow for acceleration of the plate. Determine the negative pressure required to lift the plates if the density of steel is $8054.3 \times 10^{-9} \text{ kg/mm}^3$. [6]
- Q9)** a) Explain use of strain gauges for force sensing. [6]
b) Write a note on redundant Robot. [4]
c) Explain use of robot in arc welding. [6]

OR

- Q10)**a) Explain different types of speed reduction & transmission systems used in robots. [6]
b) Explain use of robot in the assembling. [6]
c) Write various technical features required of robot for spot welding and spray coating applications. [4]
- Q11)**a) Explain various performance characteristics of induction motors. [6]
b) Write note on stepper motor. [6]
c) Compare hydraulic & electrical actuator based on weight, resolution, operating pressure and cost. [4]

OR

- Q12)**a) Explain various methods used to enter the programming command into the controller memory. [6]
b) Explain generations of robot programming languages. [4]
c) Explain WAIT, DELAY, SIGNAL command with suitable examples. [6]



Total No. of Questions : 12]

SEAT No.:

P1186

[Total No. of Pages : 2

[4164]-35
B.E. (Mechanical Engineering)
COMPUTATIONAL FLUID DYNAMICS
(2003 Pattern) (Elective - II) (Sem. - II)

Time : 3 Hours]

[Max. Marks : 100

Instructions to the candidates:

- 1) *Answer to the two sections should be written in separate answer books.*
- 2) *Figures to the right indicate full marks.*
- 3) *Neat diagrams must be drawn wherever necessary.*
- 4) *Assume suitable data, if necessary and mention it clearly*

SECTION - I

- Q1)** a) Derive the continuity equation in differential form for infinitesimally small fluid element fixed in space. **[12]**
- b) Explain the significance of substantial derivative. **[4]**

OR

- Q2)** a) For the matrix equation $Ax = b$, write down the conjugate gradient algorithm for A being symmetric and positive definite. What is the strategy for preconditioning? **[12]**
- b) Classify PDEs with suitable examples. **[4]**

- Q3)** a) Solve $\frac{dy}{dx} = \frac{1}{x+y}$ subject to $x = 0, y = 1.1$ to find y at 0.2 taking $h = 0.1$. **[8]**

- b) Outline the procedure for adaptive stepping with Runge Kutta scheme. **[8]**

OR

- Q4)** List the full procedure for the solution of Blasius equation using shooting method. **[16]**

- Q5)** Consider the first order wave equation. **[18]**

$$\frac{\partial u}{\partial t} + c \frac{\partial u}{\partial x} = 0$$

Write above equation in discretised form and obtain condition for stability of its numerical solution.

P.T.O.

OR

- Q6)** a) List the two types of errors encountered in numerical methods and indicate how the error occurs? [8]
b) Derive the forward and central difference approximations to the first order derivative along with the leading error term. [10]

SECTION - II

- Q7)** a) Write down the transient and steady state heat conduction equation for 1D and 2D problems. Discuss the explicit formulation for 1D transient problem. Illustrate by suitable example the solution procedure for a practical problem. [10]
b) Discuss the two dimensional transient problem and its solution algorithm. [6]

OR

- Q8)** Consider thermally developing flow and hydrodynamically developed flow inside the circular pipe. [16]
a) Write governing equation with boundary conditions.
b) Write equation in discretised form.
c) Present the probable solution method.

- Q9)** For quasi-one dimensional compressible flow in nozzle, [8]
a) Write the simplified governing equations.
b) Solve the continuity equation using MacCormack method. [8]

OR

- Q10)** Write short note on :
a) Finite volume method. [8]
b) Thomas algorithm. [8]

- Q11)** Write the Navier-Stokes equation for compressible flow. Explain the solution algorithm for this case. [18]

OR

- Q12)** a) Write down step by step procedure for SIMPLE algorithm. [10]
b) Explain the merits and demerits of explicit, implicit and semi implicit methods. [8]



Total No. of Questions : 10]

SEAT No.:

P1187

[Total No. of Pages : 2

[4164]-37
B.E. (Mechanical Engineering)
RAPID PROTOTYPING
(2003 Pattern) (Elective - II) (Sem. - II)

Time : 3 Hours]

[Max. Marks : 100

Instructions to the candidates:

- 1) *Solve any three questions from each section.*
- 2) *Answers to the two sections should be written in separate answer books.*
- 3) *Figures to the right indicate full marks.*
- 4) *Neat diagram should be drawn wherever necessary.*
- 5) *Assume suitable data, if necessary.*

SECTION - I

- Q1)** a) Describe the five steps involved in a general RP process with sketch. Which steps do you think likely to be altered? **[8]**
- b) How RP technology has been revolutionizing the manufacturing industry? Discuss in detail with examples. **[8]**
- Q2)** a) Explain with example benefits of RP to ; **[8]**
- i) Marketing Engineer.
 - ii) Design Engineer.
 - iii) Tool Designer.
 - iv) Production Engineer.
- b) Define models and explain their influence to speed up product development process with neat sketch. **[8]**
- Q3)** a) How can bringing a product to market rapidly have an impact on the rate of return and how it affects the outcome of other competitive products? Elaborate with a example. **[8]**
- b) Explain with neat sketch SLS process in detail along with its merits and demerits. Further compare the SLS with Stereolithography. **[8]**
- Q4)** a) Explain the following terms : **[8]**
- i) RM.
 - ii) IGES.
 - iii) STL.
 - iv) BPM.

P.T.O.

- b) Define : [8]
- i) RP.
 - ii) RT.
 - iii) Rapid Manufacturing (RM).

Relate RP, RT, RM to the basic product development process with neat diagram.

Q5) Write short notes (Any Three) : [18]

- a) Simultaneous Engineering.
- b) SGC.
- c) Data acquisition techniques in Reverse Engineering.
- d) FDM.

SECTION - II

Q6) a) Classify Rapid Prototyping on the basis of materials used with example of each type. [8]

- b) What are the latest trends in RP material development. [4]
- c) Explain with sketch stair stepping effect in RP. [4]

Q7) a) What is meant by RTV? Describe how it works with figures. [8]

- b) What are the differences between rapid tooling and conventional tooling? [4]
- c) Explain the concept of Support structure and material in RP with neat sketch. [4]

Q8) a) Explain with neat sketch Spray Metal Molding process. [8]

- b) What is LENSE? How does it works? [4]
- c) Which are the operative aspects in RP? [4]

Q9) a) What are the important factors influencing the cost of RP process? Elaborate with suitable example. [8]

- b) Explain the application of RP technology in Art, Archeology and Architecture. [8]

Q10) Write short notes (Any Three) : [18]

- a) DSPC.
- b) Guidelines for implementation of RP.
- c) Future trends in RP process development.
- d) Make or Buy decision in RP.



Total No. of Questions : 10]

SEAT No.:

P1188

[Total No. of Pages : 4

[4164]-38
B.E. (Mechanical Engg.)
RELIABILITY ENGINEERING
(2003 Pattern) (Elective - II) (Sem. - II)

Time : 3 Hours]

[Max. Marks : 100

Instructions to the candidates:

- 1) Answer three questions from each section.*
- 2) Neat Diagrams must be drawn wherever necessary.*
- 3) Assume suitable data, if necessary.*
- 4) Figures to the right indicate full marks.*
- 5) Use non-programmable electronic calculators is allowed.*

SECTION - I

Q1) a) Calculate the reliability of the system shown in Fig.1. The values in the block show the reliability of individual components in the system. **[10]**

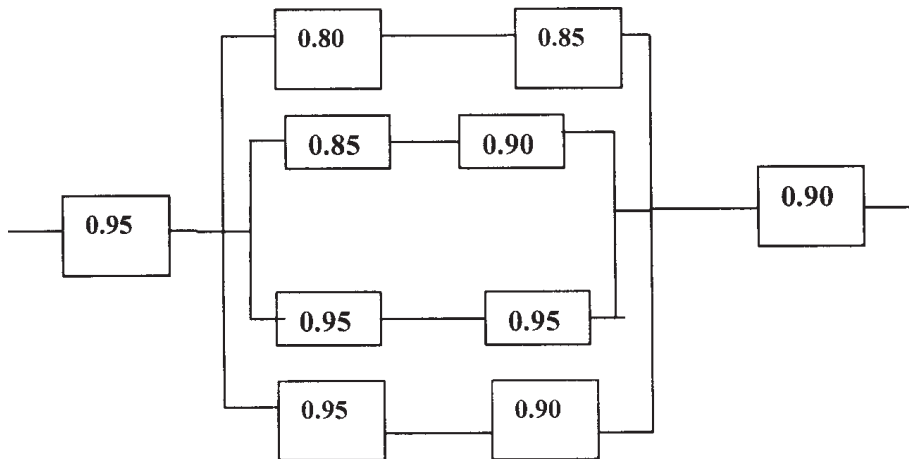

Fig. 1

b) Explain reliability and maintainability trade off for availability output. **[8]**

P.T.O.

- Q2)** a) Explain conditional probability method of reliability evaluation using simple example. [8]
 b) What is mean by redundancy? Explain types of redundancies. [8]
- Q3)** a) Explain the process of FMEA analysis for any given system. [8]
 b) Ten identical items with constant failure rate were put on test and their failure times (in hrs.) were observed to be 10, 17, 25, 33, 34, 41, 48, 59, 72, 79. Calculate the MTTF and hence reliability at 20 hours. [8]
- Q4)** a) Fig.4 shows a system configuration with reliability of elements given in blocks. The find the system reliability. [8]

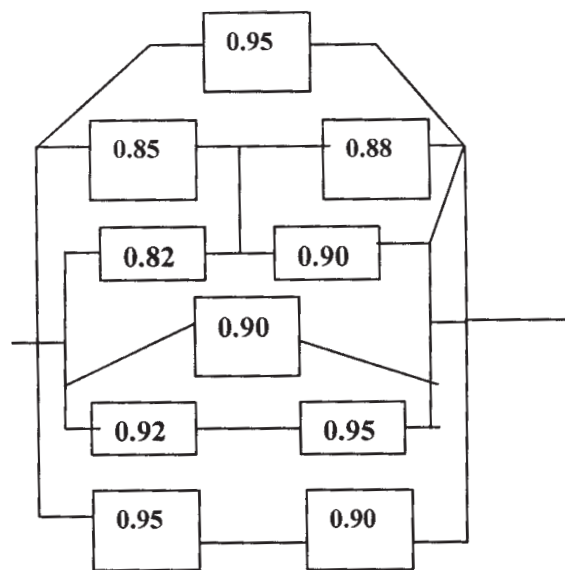

Fig. 4

- b) Define minimal tie set and minimal cut set. Write all the possible tie sets and cut sets for the system shown in Fig.5. Obtain minimal tie sets and minimal cut sets. [8]

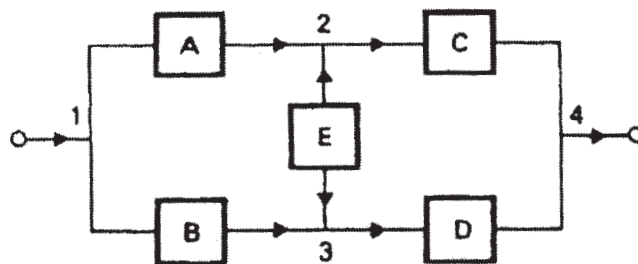

Fig. 5

Q5) Write short note on following (Any Two) : **[18]**

- a) Markov Analysis.
- b) Graph Theory Approach.
- c) Severity, Occurrence and Detection in relevance to RPN calculation.
- d) AGREE method for Reliability allocation.

SECTION - II

Q6) a) Explain the concept of safety margin and loading roughness. **[8]**

b) Explain the weibull distribution used in reliability analysis. **[8]**

Q7) a) Define accelerated life testing. Explain the life testing methods carried out for reliability analysis. **[6]**

b) In a short sample life testing of a system the following data is recorded as follows : **[10]**

Failure No.	1	2	3	4	5	6	7	8	9	10
MTTF (Hrs.)	20	21	16	26	30	38	30	19	25	25

Plot the variation of reliability against time using

- i) Mean Ranking and
- ii) Median Ranking Method.

Q8) a) Four units are connected in series with reliabilities $R_1 = 0.85$, $R_2 = 0.9$, $R_3 = 0.8$ and $R_4 = 0.95$. Calculate the system reliability. If the reliability is to be increased to a value of 0.70, how this should be apportioned among the four units according to the minimum effort method. **[8]**

b) The following data refer to predicted reliability of six components in series. In case the desired reliability of the system is not to fall below 0.80 find the reliability goal for individual components. **[8]**

Components	1	2	3	4	5	6
Predicted reliability	0.99	0.93	0.995	0.998	0.95	0.98

- Q9)** a) Explain K-statistics method for reliability evaluation. **[8]**
- b) The mean strength and the standard deviation of a bolted joint are 3000Kg/cm² and 200Kg/cm² respectively. The joint is loaded such that stress induced has a mean value of 2600Kg/cm² with a standard deviation of 150Kg/cm². Assuming that shear strength and the induced stresses are independent and normally distributed, find out the probability of survival of the bolted joint. Extract of data from statistical table is given below : **[8]**

Z	1.2	1.3.	1.4	1.5	1.6	1.7	1.8
φ (z)	0.8849	0.9032	0.9192	0.9331	0.9452	0.9550	0.9640

- Q10)** Write short notes on (Any Two) : **[18]**
- a) Fault tree construction.
- b) Wear debris monitoring.
- c) Vibration signature analysis.



Total No. of Questions : 12]

SEAT No.:

P1189

[Total No. of Pages : 3

[4164]-39
B.E. (Mechanical)
AUTOMOBILE ENGINEERING
(2003 Pattern) (Elective - II) (Sem. - II)

Time : 3 Hours]

[Max. Marks : 100

Instructions to the candidates:

- 1) Answer three questions from Section-I and three questions from Section-II.*
- 2) Answers to the two sections should be written in separate books.*
- 3) Neat diagrams must be drawn wherever necessary.*
- 4) Figures to the right indicate full marks.*
- 5) Use of logarithmic tables, slide rule, Mollier charts, electronic pocket calculator and steam tables is allowed.*
- 6) Assume suitable data, if necessary.*

SECTION - I

- Q1)** a) What do you understand by specifications of an automobile? Give in details specifications of any LMV of your choice. **[8]**
- b) Write down detailed note on classification of vehicles and applications of it. **[8]**

OR

- Q2)** a) What are various loads which a vehicle frame has to withstand? Describe briefly the functions of a frame. **[8]**
- b) Explain with neat sketch following types of vehicle chassis layout. **[8]**
- i) Front wheel drive.
 - ii) All wheel drive.

- Q3)** a) Describe working of an automobile clutch with neat sketch. Explain construction of friction plate used in it. **[8]**
- b) Explain why gear box is necessary in vehicle? Explain working principle of it. **[8]**

OR

P.T.O.

- Q4)** a) Explain the working of a selector mechanism in a manual gear box. Discuss advantages and disadvantages of it. [8]
- b) A truck is weighing 30kN and has its frontal projections area as 3.5m² and running at its peak speed 80kmph. Calculate the power required to propel it. Assume mechanical efficiency of an engine as 80% and transmission efficiency 85%, $c_r = 0.02$ and $c_d = 0.035N^2/m^2-hr/km^2$ and $\rho = 1$. [8]

- Q5)** a) Describe necessity of suspension system an automobile vehicles. Explain meaning of rolling pitching and bouncing refer to suspension system.[8]
- b) Explain the following : [10]
- i) Inter connected suspension system.
- ii) Macpherson strut front suspension.

OR

- Q6)** Write short note on the following (Any Three) : [18]
- a) Anti-roll device.
- b) Sprung and unsprung mass.
- c) Constant mesh gear box.
- d) Suspension springs.

SECTION - II

- Q7)** a) Draw a neat sketch of a rigid front axle. How wheel turns on it for steering. [8]
- b) Explain with sketch following terms : [8]
- i) Castor.
- ii) Camber.
- iii) King-pin inclination.
- iv) Toe in-Toe out.

OR

- Q8)** a) What is power steering? Describe with neat sketch working of it. [8]
- b) Describe with neat sketch working of worm and sector type of steering gear. [8]

- Q9)** a) Explain construction of a telescopic type propellor shaft. Why it is needed? [8]
- b) Describe working of gears used in final drive. [8]

OR

- Q10)** a) Draw a neat sketch of tyre (tubed type) and explain construction of it. [8]
b) Differentiate the following : [8]
i) Bias-ply tyre and radial tyre.
ii) Car wheel rim and scooter wheel rim.

- Q11)** a) Describe Air Brake System with neat sketch. [6]
b) Explain with neat sketch construction and working of lead-acid battery. [6]
c) Draw a simple wiring diagram of a car. [6]

OR

- Q12)** Write short note on the following (Any Three) : [18]
a) Master Cylinder.
b) Power boosters.
c) Automobile horn.
d) Tubeless tyre.
e) Periodical maintenance of automobile.



Total No. of Questions : 12]

SEAT No.:

P1190

[Total No. of Pages : 4

[4164]-40

B.E. (Mechanical & Mechanical S/W)

DESIGN ENGINEERING

(2003 Pattern) (Sem. - I)

Time : 4 Hours]

[Max. Marks : 100

Instructions to the candidates:

- 1) Answer three questions from section-I and three questions from section-II.
- 2) Answers to the two sections should be written in separate books.
- 3) Neat diagrams must be drawn wherever necessary.
- 4) Figures to the right indicate full marks.
- 5) Use of logarithmic tables, slide rule, Mollier charts, electronic pocket calculator and steam tables is allowed.
- 6) Assume suitable data, if necessary.

SECTION - I

- Q1) a) What are the advantages of spiral bevel gear over straight bevel gears?[4]
- b) A pair of straight teeth bevel gears are mounted on shafts which are intersecting at right angles. The pinion shaft is connected to a electric motor developing 16.5kW power at 500 rpm. The number of teeth on gear and pinion are 45 and 30 respectively. The tooth form correspond to 20° pressure angle, full depth involute. The service factor and load concentration factor can be taken as 1.5 and 1.6 respectively. The pinion and gear are made of steel having ultimate tensile strength of 570 MPa and surface hardness of 350 BHN. The module and face width of tooth are 6mm and 50mm respectively. The axial face width of gear blank can be taken as 40mm.

$$\text{Wear load factor } K = 0.16 \left(\frac{\text{BHN}}{100} \right)^2 \text{ N/mm}^2 \cdot C_v = \frac{5.6}{5.6 + \sqrt{V}}$$

Determine the factor of safety for bending and pitting.

$$\text{Take } Y = 0.484 - \frac{2.85}{Z_p^1}$$

[14]

P.T.O.

OR

- Q2)** a) Explain beam strength and wear strength of worm gears. [8]
b) The worm gear pair is designated as 1/30/10/5. Calculate :
i) The major dimensions of the worm and wheel.
ii) The center distance. iii) Reduction ratio.
iv) Efficiency of gear box if $\mu = 0.1$ and normal pressure angle of teeth is 20° . [10]

- Q3)** a) A seamless cylinder of storage capacity 0.0245m^3 and made of alloy steel 20Mo55 ($\sigma_{ut} = 450\text{ N/mm}^2$) is to be used to store a fluid at 14MPa gauge pressure. The length of the cylinder is twice its inner diameter. If the factor of safety is 3, determine the cylinder dimensions. [7]
b) Explain the various types of supports for pressure vessels. [6]
c) The cylinder of a hydraulic accumulator made of gray cast iron FG200 has an inner diameter of 350mm. The maximum internal pressure is 8MPa. If the factor of safety is 5, determine the thickness of the cylinder. [3]

OR

- Q4)** a) The following data refers to the vertical pressure vessel with hemispherical ends, used to store the gas at a pressure of 1.5MPa and temperature of 20°C . The vessel shell as well as the hemispherical ends are made of plain carbon steel.
Inner diameter of the vessel shell = 2m.
Length of the vessel shell including the straight = 3m.
Flange portions of the hemispherical ends.
Density of the gas inside the vessel = 1200kg/m^3 .
Maximum wind speed = 200km/hr .
Torque due to offset piping on vessel shell = 2kN.m .
Ultimate tensile strength of the vessel material = 450 N/mm^2 .
Density of the vessel material = 7800kg/m^3 .
Efficiency of welded joints = 85%.
The wind pressure is given by,
 $p = 4.623 \times 10^{-8} V_w^2\text{ N/mm}^2$.
where V_w = wind speed in km/hr.
Determine :
i) Thickness of hemispherical shell.
ii) Thickness of vessel shell.
iii) Stress in circumferential direction.
iv) Stress in longitudinal direction due to internal pressure. [10]
b) Explain any three methods of pre-stressing the high pressure cylinders. [6]
- Q5)** a) What is 'Design for manufacture'? Explain general principles to be followed while designing parts for manufacture. [6]
b) A shaft and hole assembly have the following dimensions;

Shaft diameter = $40 \pm 0.18\text{mm}$.

Hole diameter = $40.2 \pm 0.24\text{mm}$

Assuming the shaft and hole diameters are normally distributed, determine the probability of interference fit between the shaft and the hole.

Refer following table for the area below the standard normal distribution curve. [10]

Z	0	1	2	3	4
1.9	0.4713	0.4719	0.4726	0.4732	0.4738
2.0	0.4772	0.4778	0.4783	0.4788	0.4793
2.1	0.4821	0.4826	0.4830	0.4834	0.4838

OR

- Q6)** a) Explain important considerations for designing components for forging. [8]
- b) What is 'design tolerance' and 'natural tolerance'. How the designer would select the tolerances for the minimum rejection of the components? [8]

SECTION - II

- Q7)** a) Derive the equation for the fatigue stress for a component subjected to completely reversed stresses and for finite life. [6]
- b) A cold drawn steel rod of circular c/s is subjected to a variable bending moment which varies from 565Nm to 1130Nm as the axial load varies from 4500N to 13500N. The maximum bending moment occur at the same instant that the axial load is minimum. The effect of stress concentration may be neglected. If the factor of safety is 2. Find the diameter of rod using maximum shear stress theory. [12]

Assume following data.

Ultimate tensile strength = 550MPa.

Yield strength = 470MPa.

Surface finish factor = 0.82.

Size factor = 0.8.

Reliability factor = 0.897

OR

- Q8)** a) State and explain modified Soderberg diagram for springs. Also derive the equation for the shear stress induced. [6]

- b) A cantilever beam of circular cross section is fixed at one end and subjected to completely reversed force of 10kN at free end. The force is perpendicular to the axis of beam. The distance between free and fixed ends is 100mm. The beam is made of steel with ultimate tensile strength of 540MPa and yield strength of 320MPa. The site factor, surface finish factor and reliability factor are 0.85, 0.8 and 0.868 respectively. Temperature factor is 1.01. If the diameter of beam is 35mm, find the life of the beam. [12]

- Q9)** a) Design a tensile bar of length 200mm to carry a tensile load of 5kN for minimum cost out of the following materials. Find the area for optimum material. [10]

Material	Mass density kg/m ³	Material cost Rs/weight	Yield strength MPa
Steel	7500	16	130
Al alloy	3000	32	50
Ti alloy	4800	480	90
Mg alloy	2100	32	20

- b) State and explain types of problems in the method of optimum design. [6]

OR

- Q10)** A cantilever beam of diameter 'd' and length 'L' is subjected to a vertical force of 'P' and torque 'M_T' at its free end. Outline the procedure of optimum design on the basis of maximising the strain energy absorbing capacity using following materials.

- Steel.
- Al alloy.
- Ti alloy.
- Plastic.

Following geometrical limits are applicable $L \leq L_{\max}$, $d \leq d_{\max}$

$$G = \frac{E}{2(1+\mu)} \tau_{\max} = \frac{S_y}{2(fs)} \quad [16]$$

- Q11)** a) Draw and explain man machine closed loop system. [6]
b) Draw and explain different types of drive units for belt conveyor. [10]

OR

- Q12)** a) Draw different types of control and state their applications. [8]
b) Draw and explain various devices for belt dealing. [8]



Total No. of Questions : 6]

SEAT No.:

P1191

[Total No. of Pages : 2

[4164]-49
B.E. (Mech./Mech.Sandwich)
PRODUCTION MANAGEMENT
(2003 Pattern) (Elective - III) (Sem. - II)

Time : 3 Hours]

[Max. Marks : 100

Instructions to the candidates:

- 1) *Answers to the two sections should be written in separate books.*
- 2) *Neat diagrams must be drawn wherever necessary.*
- 3) *Figures to the right indicate full marks.*
- 4) *Use of logarithmic tables slide rule, Mollier charts, electronic pocket calculator and steam tables is allowed.*
- 5) *Assume suitable data, if necessary.*
- 6) *All questions are compulsory.*

SECTION - I

- Q1)** a) What is method study? Discuss briefly the steps in carrying out method study. [8]
- b) Define work sampling. How it is used in establishing standard time for a job? [7]
- c) Define 'qualified worker'. [3]

OR

- a) Discuss in brief the various recording techniques used in method study. [6]
- b) Explain 'MTM' in detail. [6]
- c) Explain in brief the various methods of performance rating. [6]

- Q2)** a) Define Ergonomics and explain its importance in industry. [8]
- b) Discuss the aspects of Man-Machine system interface. [8]

OR

Write short notes on : [16]

- a) Antropometry.
- b) Work space design.
- c) Effect of noise and humidity on human performance.

- Q3)** a) What is group dynamics? How it is useful in quality management? [8]
- b) Discuss in brief various costs associated with quality. [8]

P.T.O.

OR

- a) Discuss in detail the PDCA cycle. [8]
- b) Mention any eight points suggested by Dr.Deming. [8]

SECTION - II

- Q4)** a) Enlist various QC tools and explain any one with illustrative example.[8]
b) Ten Hand woven carpets were studied critically for total number of defects in their texture. The details of number of defects in each carpet are given below :

Carpets No. -	1	2	3	4	5	6	7	8	9	10
No. of defects -	2	4	3	5	1	3	2	3	4	3

All carpets were accepted by QC dept. of company. Construct a appropriate control chart for number of defects and comment on the solution. [6]

- c) Explain in brief the meaning of ‘QFD’. [4]

OR

- a) Mention the five standards of ISO good series. [5]
- b) Discuss briefly the motorola’s process for six sigma. [9]
- c) Name the eight pillan’s of TPM. [4]

- Q5)** a) What is Kaizen? What advantages can an organisation derive from implementation of Kaizen? [8]
b) Define Benchmarking. Discuss the various levels of BM. [8]

OR

- a) Which precautionary measures should be taken into consideration in TQM implementation? [8]
- b) Discuss in detail the ‘Change Management’ process. [8]

- Q6)** a) What is concurrent engineering? What is its need? Discuss the role of IT and computers in CE. [8]
b) What are the matrices and benefits of QFD? [8]

OR

- a) Define value engineering and value analysis. Mention the steps in value analysis. Differentiate between VE and cost reduction techniques. [8]
- b) What is design for manufacturing and design for assembly. [8]



Total No. of Questions : 12]

SEAT No.:

P1192

[Total No. of Pages : 2

[4164]-50
B.E. (Mech./Mech.S/W)
MACHINE TOOL DESIGN
(2003 Pattern) (Elective - III) (Sem. - II)

Time : 3 Hours]

[Max. Marks : 100

Instructions to the candidates:

- 1) *Answers to the two sections should be written in separate books.*
- 2) *Neat diagrams must be drawn wherever necessary.*
- 3) *Figures to the right indicate full marks.*
- 4) *Use of logarithmic tables slide rule, Mollier charts, electronic pocket calculator and steam tables is allowed.*
- 5) *Assume suitable data, if necessary.*

SECTION - I

Unit - I

- Q1)** a) Explain construction and working of Norton gear box. [10]
b) Discuss design considerations of speed regulation in cone variator. [8]

OR

- Q2)** a) Discuss the recent trends in Machine Tool Design with respect to [10]
i) Operating speed range.
ii) Accuracy.
iii) Control systems.
b) Explain PIV drive with block diagram. [8]

Unit - II

- Q3)** a) Discuss design of Feed gear box in detail. Also state its features. [8]
b) State different progressions used in designing gear box with applications. [8]

OR

- Q4)** Design a three stage 12 speed gear box transmitting 7.5KW power with Speeds from 80 rpm to 1000 rpm. The minimum number of teeth on gear 17. Electric motor speed is 1440 rpm. Draw structural diagram and also Calculate number of teeth on gears. [16]

P.T.O.

Unit - III

- Q5)** a) Describe various methods used for compensation of wear of guides. [8]
b) Describe stick-slip sliding. Explain its remedies. [8]

OR

- Q6)** a) What is static and dynamic stiffness? What is their effect on selection of Material for slideways? [8]
b) Discuss various types of lubrication systems for beds and slideways.[8]

SECTION - II

Unit - IV

- Q7)** a) Describe working of a ball recirculating power screws. Explain how preloading is carried out in ball screws. [10]
b) Discuss design considerations for spindle unit of machine tool. [8]

OR

- Q8)** a) What is the importance of power screws in machine tools? Discuss design factors to be considered while designing. [10]
i) Sliding friction power screws.
ii) Rolling friction power screws.
b) Explain how the optimum spacing between spindle supports is determined while designing the machine tool spindles. [8]

Unit - V

- Q9)** a) Explain hydraulic system used in shaper. [8]
b) Explain hydraulic system used for chuck clamping in machine tools. [8]

OR

- Q10)** a) What is adaptive control system? How it is used in recent machine tools? [8]
b) Explain principle and working of Electric braking system in machine tools. [8]

Unit - VI

- Q11)** a) State and discuss design features of NC and CNC machines. [8]
b) Explain part programming of CNC machines. [8]

OR

- Q12)** a) Discuss types of ATC (Automatic Tool Changer). [8]
b) Explain Closed loop system of CNC machine in details. [8]

☒☒☒☒

Total No. of Questions : 12]

SEAT No.:

P1193

[Total No. of Pages : 3

[4164]-52

B.E. (Production Engineering)

MACHINE TOOL DESIGN

(2003 Pattern) (Sem. - I) (Common to Production Sandwich)

Time : 3 Hours]

[Max. Marks : 100

Instructions to the candidates:

- 1) *Attempt one question of each unit form section-I and section-II.*
- 2) *Answer to the questions should be written on separate books.*
- 3) *Draw neat diagram wherever necessary.*
- 4) *Assume suitable data if required*

SECTION - I

Unit - I

- Q1)** a) What are the differences between structure diagram and ray diagram? What is the criterion for selecting the best ray diagram for a speed gear box? [6]
- b) Explain the principle of self locking variator. [6]
- c) Explain with a neat sketch of Svetozarov's (spheroid with swivelling discs) variators? State the advantages and limitation of stepless drive over stepped drive. [8]

OR

- Q2)** a) Draw a structural diagram, ray diagram and gear layout of a machine tool speed box for $N_{min} = 50$ rpm, $N_{max} = 770$ and speed ratio = 1.26. [14]
- b) Compare gear box used for lathe and drilling machine. [6]

Unit - II

- Q3)** a) What are the desirable properties of materials used for making machine tool structure? State the materials commonly used. [7]
- b) What are the factors affecting stiffness of machine tool structure and methods of improving it. [8]

OR

P.T.O.

- Q4)** a) State the commonly used column sections and their applications. State the most important design consideration for column of machine tool. [8]
b) What are design consideration for a machine tool elements like housing, bases, table. [7]

Unit - III

- Q5)** a) Explain with different methods of clearance adjustment for slideways. [8]
b) Explain the term backlash in power screw. What are the different methods in adjusting backlash. [7]

OR

- Q6)** a) Describe the design procedure of lead screw of a machine tool. [8]
b) What are the major requirements of guideways suitable for machine tool. [7]

SECTION - II

Unit - IV

- Q7)** a) Discuss the design consideration of a machine tool spindle. [8]
b) Draw neat sketches for spindle support in lathe milling and vertical boring machine. [6]
c) Discuss the methods of preloading of bearing. [6]

OR

- Q8)** a) Describe the various elements of a spindle unit used in a lathe machine. Draw the neat sketch of the arrangement. [7]
b) Derive a maximum load on ball bearing is $P = 5R/Z$ where R = Total load, Z = number of balls. [8]
c) Explain selection of bearing is done for machine tool. [5]

Unit - V

- Q9)** a) Explain the term dynamic rigidity of a machine tool. How is it estimated? [7]
b) What are the functions of a control system of machine tool? State the advantages of hydraulic control system. [8]

OR

- Q10)** a) State and explain the causes of chatter in lathe operation. Suggest suitable remedial measures for reducing chatter. [7]
b) With a sketch explain how to prevent overloading of a electric motor. [8]

Unit - VI

Q11) Write a short note on following : **[15]**

- a) Table feed control in planer machine.
- b) Unit head machine tool.
- c) Retrofitting of milling machine tool.

OR

Q12) a) What are the design considerations of SPM? **[8]**

b) Explain tooling requirements in CNC machine tool. **[7]**



Total No. of Questions : 12]

SEAT No. :

P1195

[Total No. of Pages : 3

[4164] - 57

B.E. (Production)

PLANT ENGINEERING AND MAINTENANCE

(2003 Pattern) (Sem. - I) (Elective - I)

Time : 3 Hours]

[Max. Marks : 100

Instructions to the candidates:-

- 1) *Answer Que. No.1 or Que. No 2, Que. No.3 or Que. No. 4, Que. No. 5 or Que. No. 6 from Section - I and Que. No. 7 or Que. No. 8. Que. No. 9 or Que. No. 10, Que. No. 11 or Que. No. 12. From Section - II.*
- 2) *Answers to the two sections should be written in separate books.*
- 3) *Neat diagrams must be drawn wherever necessary.*
- 4) *Figures to the right indicate full marks.*
- 5) *Assume suitable data, if necessary.*

SECTION - I

Unit - I

- Q1)** a) Explain in short various Plant Engg. Functions. [8]
b) Discuss various considerations to be made for location of following industries. [8]
i) Cement Industry.
ii) Automobile Industry.

OR

- Q2)** a) In your opinion which aspect should be covered by a plant. Engg. Department in a manufacturing unit? [8]
b) What possible error can be committed in new site selection? [8]

Unit - II

- Q3)** a) What is the use of REL chart? How is it prepared? [8]
b) Explain the various charting techniques used in 'Flow of materials' analysis stage of systematic layout planning (SLP)? [8]

OR

- Q4)** a) Explain in short various accident prevention practices. [8]
b) Write short notes on : [8]
i) CRAFT
ii) CORELAP.

P.T.O.

Unit - III

- Q5)** a) Write short notes on : [8]
i) Estimating capacity requirement for water.
ii) Effluents water treatment.
- b) Explain the following principle of material handling : [10]
i) Space.
ii) Gravity.
iii) Simplification
iv) Unit Load.
v) System.

OR

- Q6)** a) What points you will consider if you are asked to improve the present material handling system? [8]
- b) Plant layout and material handling are independent activities. Both need to be carried out simultaneously explain. [10]

SECTION - II

Unit - IV

- Q7)** a) Explain the Primary and Secondary functions of maintenance department?[8]
- b) How can effectiveness of preventive maintenance help the maintenance department? [8]

OR

- Q8)** a) Write short notes on ; [8]
i) History cards for equipments.
ii) Condition based maintenance.
- b) Discuss the relationship between maintenance and efficiency for an organization. What sort of maintenance schedule will you suggest for machine shop? [8]

Unit - V

- Q9)** a) Discuss in detail the importance of lubricants in the context of the maintenance function? [8]
- b) Discuss the factors which need to be considered for implementation of an efficient Spare Parts control system? [8]

OR

- Q10)** a) How the chemical effects be useful in assessing the condition of equipment? Explain briefly? [8]
b) Briefly explain the techniques which can be used for the detection of corrosion in machinery. [8]

Unit - VI

- Q11)** a) Discuss the various distribution functions used for the estimation of reliability in the performance of the maintenance functions. [10]
b) What is MTBF? Describe a typical example where MTBF concept can be applied? [8]

OR

- Q12)** a) Explain how computers can be helpful in discharge of maintenance functions. [8]
b) Write short notes on [10]
i) Reliability centered maintenance (RCM).
ii) Total Productive Maintenance (TPM).



Total No. of Questions : 12]

SEAT No.:

P1205

[Total No. of Pages : 3

[4164]-73

B.E. (Production) (Prod. S/W)

SUPPLY CHAIN MANAGEMENT

(2003 Pattern) (Elective - II) (Sem. - II)

Time : 3 Hours]

[Max. Marks : 100

Instructions to the candidates:

- 1) Answer Q.No. 1 or Q.No. 2, Q.No. 3 or Q.No. 4, Q.No. 5 or Q.No. 6 from section-I and Q.No. 7 or Q.No. 8, Q.No. 9 or Q. No. 10, Q.No. 11 or Q.No.12 from section-II.
- 2) Answers to the two sections should be written in separate books.
- 3) Neat diagrams must be drawn wherever necessary.
- 4) Figures to the right indicate full marks.
- 5) Assume suitable data, if necessary.
- 6) Use of logarithmic tables, slide rule, Mollier charts, electronic pocket calculator and steam table is allowed.

SECTION - I

Unit - I

- Q1)** a) Identify cycles & push-pull boundary in supply chain when you are purchasing NOKIA MOBILE PHONE from a shop in your city. [10]
b) Discuss primary and secondary objectives of supply chain management. [8]

OR

- Q2)** a) Describe in brief the obstacles of supply chain performance and list out major drives. [9]
b) Discuss the roll of 'sourcing' in supply chain & list the sourcing related Metrics (performance measures). [9]

Unit - II

- Q3)** a) What are the different methods of forecasting? Discuss them briefly.[8]
b) Discuss the aggregate planning problems in short. Which information is needed for an aggregate planner? Which decisions are based on this information? [8]

OR

P.T.O.

- Q4)** a) How firm can vary the 'Supply' by managing capacity and the inventory? [8]
b) Explain in short the role of IT in forecasting. [8]

Unit - III

- Q5)** a) When the quantity discounts are justified in a supply chain? Differentiate between lot size based and volume based quantity discounts? [8]
b) Describe the two type's orderly policies & impact that each of them has on safety inventory. [8]

OR

- Q6)** a) What is the roll of safety inventory in supply chain? How the appropriate level of safety inventory is determined? [8]
b) What is the product availability? How it is measured? Describe two types of replenishment policies. [8]

SECTION - II

Unit - IV

- Q7)** a) Discuss the roll of transportation in supply chain. Mention the various modes of transportation with their strengths and weaknesses. [9]
b) Why is IT the key component of SCM system? "Successful IT implementation is the outgrowth of the participation of knowledge workers". Comment with examples. [9]

OR

- Q8)** a) Discuss various options available for designing of Transportation Network. [9]
b) Discuss the importance of information and information technology in supply chain. [9]

Unit - V

- Q9)** a) How the design of distribution network in various types of industry has been affected due to evolution of E-business? [9]
b) Which are the major obstacles for coordination in supply chain? Discuss in brief. [7]

OR

- Q10)** a) What is bull whip effect and how does it relate lack of coordination in supply chain. [8]
b) Discuss the impact of E-business on customer service. [8]

Unit - VI

- Q11)** a) Mention the ideas considered by Managers to make better network design decisions under uncertainty. [7]
- b) What is 'Discounted Cash Flow Analysis'? Why it is used in supply chain Management? How the flexibility is evaluated in supply chain? [9]

OR

- Q12)** a) What do you understand by 'Decision Tree'? Summarize basic steps in decision tree analysis. [8]
- b) Discuss the role of revenue management in supply chain. [8]



Total No. of Questions : 12]

SEAT No.:

P1213

[Total No. of Pages : 3

[4164]-89
B.E. (Electrical)
RESTRUCTURING AND DEREGULATION
(2003 Pattern) (Sem. - I) (Elective - I)

Time : 3 Hours]

[Max. Marks : 100

Instructions to the candidates:

- 1) *Answer any three questions from each section.*
- 2) *Answers to the two sections should be written in separate books.*
- 3) *Neat diagrams must be drawn wherever necessary.*
- 4) *Figures to the right indicate full marks.*

SECTION - I

Q1) Explain functions of Any Four of following institutions. **[16]**

- a) Planning Commission.
- b) Central Electricity Authority.
- c) Central Electricity Regulatory Commission.
- d) Ministry of Power.
- e) State Electricity Board.

OR

Q2) a) Explain various national policies and guidelines under these acts. **[8]**

b) Explain the objectives of 'Electricity Act 2003'. **[8]**

Q3) a) Write short note on : **[10]**

- i) Capital cost.
- ii) Debt and equity.
- iii) Operation and maintenance cost.
- iv) Fixed and variable cost.
- v) Life Cycle cost.

b) Explain the concept of subsidy and cross-subsidy. **[6]**

OR

P.T.O.

- Q4)** a) Define Tariff for Electricity. Describe factors governing the tariff structure. [8]
b) Explain Net Present Value (NPV) method with example, to assess the financial feasibility of any project. [8]

- Q5)** a) Explain the key roles of State and Central Electricity Commissions. [8]
b) Explain various non-price issues in regulation. [10]

OR

- Q6)** Write short note on following methods of regulations. [18]
a) Rate of return regulation.
b) Performance based regulation.
c) Incentive regulation.
d) Benchmarking or Yardstick regulation.

SECTION - II

- Q7)** a) Explain following models based on industry structure such as Monopoly, Single buyer, wholesale competition. [9]
b) What are the models based on contractual arrangements? Explain any two such models. [9]

OR

- Q8)** a) Compare between 'competition for the market' and 'competition in the market'. [9]
b) Explain the working of different Ownership models. [9]

- Q9)** a) Describe important rules those govern the electricity market. [8]
b) Explain the concept of retail competition. [8]

OR

- Q10)** a) Compare different trading markets as Integrated trading market and Wheeling trading market. [8]
b) Explain the impact of reform on regulation and externalities. [8]

- Q11)** a) What is the concept of transmission rights and transmission pricing? [8]
b) Explain the reasons of transmission congestion. Also explain how to manage the transmission-congestion. [8]

OR

- Q12)** a) Explain the working of following institutions. **[8]**
- i) Independent System Operator (ISO).
 - ii) Load Dispatch Center (LDC).
- b) Explain the pricing structure under Availability Based Tariff. Explain the technical benefits achieved in case of power sector. **[8]**



Total No. of Questions : 12]

SEAT No.:

P1214

[Total No. of Pages : 3

[4164]-90
B.E. (Electrical)
ENERGY MANAGEMENT
(2003 Pattern) (Sem. - II)

Time : 3 Hours]

[Max. Marks : 100

Instructions to the candidates:

- 1) *Answer any three questions from each section.*
- 2) *Answers three questions from Section-I and three questions from Section-II.*
- 3) *Answers to the two sections should be written in separate books.*
- 4) *Neat diagrams must be drawn wherever necessary.*
- 5) *Figures to the right indicate full marks.*
- 6) *Use of logarithmic tables slide rule, Mollier charts, electronic pocket calculator and steam tables is allowed.*
- 7) *Assume suitable data, if necessary.*

SECTION - I

- Q1)** a) Explain the environmental impacts due to conventional energy use. [8]
b) What is energy security. Why it is important. [8]

OR

- Q2)** a) Explain the importance of renewable energy sources in contest with the energy crisis. Give potential and present installed capacity of various renewable energy sources in India. [8]
b) Write salient features of EC Bill 2001. [8]

- Q3)** a) Write the duties of energy manager and energy auditor. [8]
b) Explain the concept of DSM. What is its aim? Explain the steps involved in DSM planning and implementation. [8]

OR

- Q4)** a) What is the concept of energy management. Industry should have energy policy. What is idea behind the energy policy. [8]
b) What is tariff? What are fixed and variable components in tariff? How does the tariff structure encourage energy conservation. [8]

- Q5)** a) Why is energy audit more relevant in present day context of Indian Power System. What are the barriers in implementing energy audit scheme in an electrical utility? [8]

P.T.O.

- b) What is CUSUM technique? What is use of CUSUM technique in energy audit, explain. [5]
- c) What is Sankey diagram? What is use of Sankey diagram in energy audit? [5]

OR

- Q6)** a) Explain the step-by-step approach for conducting energy audit for any industry. [8]
- b) List the instruments required for auditing electrical and thermal energy. [5]
- c) Explain the format for writing report for energy audit. [5]

SECTION - II

- Q7)** a) Define the following indexes used for economical analysis of energy conservation projects : [8]
- i) SPP.
- ii) NPV.
- iii) IRR.
- iv) Profitability Index.
- b) Explain TOD tariff. What are the advantages of TOD tariff and p.f. rebate in retail tariff. [8]

OR

- Q8)** a) What is use of “Break Even Analysis” technique for energy auditor? Explain. [8]
- b) Table shows capital cost and net savings for three energy conservation projects for a discount rate of 12% calculate NPV and profitability index for each project. Specify the most economical project. Projectwise capital costs are given with negative sign and the net annual savings are given with positive sign in the cash flow table. [8]

Cash Flow Table

Year	Cash flow (Lac) project - 1	Cash flow (Lacs) project - 2	Cash flow (Lacs) project - 3
0	- 5.4	- 5.4	- 7.2
1	+ 1.35	+ 1.62	+ 1.58
2	+ 1.35	+ 1.53	+ 1.69
3	+ 1.35	+ 1.44	+ 1.8
4	+ 1.35	+ 1.26	+ 1.89
5	+ 1.35	+ 1.17	+ 2.02
6	+ 1.35	+ 1.08	+ 2.14

- Q9)** a) What are the opportunities of energy conservation in HVAC? Explain. [8]
b) What is meant by luminous efficacy? Write the advantages of high frequency electronic ballast in place of conventional ballast. [8]

OR

- Q10)** a) Write advantages of CFL over GLS lamps. [8]
b) List the energy conservation opportunities for water pump system. Explain. [8]

- Q11)** a) Explain various methods for reducing T & D Loss in electrical power system. In India T and D loss is more than other countries. Why? [8]
b) Write energy audit case study for thermal power stations. [10]

OR

- Q12)** a) Explain the energy audit case study for municipal corporation. [9]
b) Explain the energy audit case study for IT industry. [9]



Total No. of Questions : 12]

SEAT No.:

P1215

[Total No. of Pages : 3

[4164]-91
B.E. (Electrical)
SWITCHGEAR AND PROTECTION
(2003 Pattern) (Sem. - II)

Time : 3 Hours]

[Max. Marks : 100

Instructions to the candidates:

- 1) *Answer three questions from each section.*
- 2) *Answers to the two sections should be written in separate books.*
- 3) *Neat diagrams must be drawn wherever necessary.*
- 4) *Figures to the right indicate full marks.*
- 5) *Use of logarithmic tables slide rule, Mollier charts, electronic pocket calculator and steam tables is allowed.*
- 6) *Assume suitable data, if necessary.*

SECTION - I

- Q1)** a) With suitable diagram, explain primary protection and backup protection. **[8]**
- b) What are the essential qualities of protective relaying. **[8]**

OR

- Q2)** a) List out the various types of faults taking place in the power system. What are the causes of these faults. **[8]**
- b) What do you mean by protective relaying? Explain the concept with block diagram? Why it is essential? **[8]**

Q3) Explain with waveform :

- a) Current chopping in Inductive circuit. **[8]**
- b) Capacitor switching. **[8]**

OR

- Q4)** a) What do you mean by restriking voltage? State and explain, the factors affecting the restriking voltage. **[8]**
- b) Explain high and low resistance principles of arc interruption. **[8]**

P.T.O.

- Q5)** a) With neat sketch, explain the construction and working principle of VCB. [8]
b) Explain the terms related to EHV circuit breaker. [10]

OR

- Q6)** Write short notes on : [18]
a) Air break circuit breaker.
b) SF₆ circuit breaker.
c) Autoreducers.

SECTION - II

- Q7)** a) Explain the inrush current phenomenon in case of a transformer. [8]
b) A 3-ph 132/11kv star/delta connected transformer is protected by differential system. The CT's on 11kv side have ratio 600/5. What must be ratio of CT's on H.T. side. Sketch the connection diagram. [8]

OR

- Q8)** a) Explain the various types of faults taking place in the alternator. [8]
b) 3-ph, 11kv, 10MVA, alternator has neutral earthed by 10Ω. The relay setting is such that it trips for 25% out of balance current. Calculate % of winding protected against earth fault. What must be the minimum value of resistance in the neutral to give 90% protection to each phase of the winding. [8]

- Q9)** a) Explain the principle of distance protection used for transmission line protection. Compare impedance, reactance and admittance relay w.r.t. their application in distance protection. [8]
b) Explain the effect of power swings and arc resistance on distance relay. [8]

OR

- Q10)** a) Draw the block diagram and explain the carrier current protection scheme used for long transmission line. [8]
b) With neat sketches, explain the three steps distance protection for transmission line. [8]

- Q11)** a) What is numerical protection? Explain with block diagram. [9]
b) Explain the operation of static relays with neat block diagrams. [9]

OR

Q12) Write short notes on :

[18]

- a) Microprocessor based over current relay.
- b) Sampling theorem.
- c) Amplitude and phase comparator.



Total No. of Questions : 12]

SEAT No.:

P1216

[Total No. of Pages : 2

[4164]-93
B.E. (Electrical)
VLSI DESIGN
(2003 Pattern) (Elective - II) (Sem. - II)

Time : 3 Hours]

[Max. Marks : 100

Instructions to the candidates:

- 1) *Answer three questions from section-I and three questions from section-II.*
- 2) *Answers to the two sections should be written in separate books.*
- 3) *Neat diagrams must be drawn wherever necessary.*
- 4) *Figures to the right indicate full marks.*
- 5) *Use of logarithmic tables slide rule, Mollier charts, electronic pocket calculator and steam tables is allowed.*
- 6) *Assume suitable data, if necessary.*

SECTION - I

- Q1)** a) Draw symbolic diagram of J-K flipflop and also explain Race-Around condition. **[8]**
b) Differentiate between mealy and moore modelling with example. **[8]**

OR

- Q2)** a) Draw and explain 4 bit serial in serial OUT shift register and also draw its timing diagram with suitable example. **[10]**
b) Develop 8:1 mux using 4:1 mux and 2:1 mux. **[6]**

- Q3)** a) What is configuration? Explain with VHDL code example. **[10]**
b) Define : **[8]**
i) Entity.
ii) Architecture.
iii) Component.
iv) Bus also give its syntax in VHDL.

OR

- Q4)** a) Write VHDL code for 2×4 decoder and also draw its internal gate level diagram. **[8]**
b) Explain with VHDL code 8:1 multiplexer with : **[10]**
i) Behavioral model.
ii) Structural model and
iii) Data flow model.

P.T.O.

- Q5)** a) Explain any four data types and data objects. [8]
b) Explain process statement with suitable example. [8]

OR

- Q6)** a) Define with example : [8]
i) Package.
ii) Attributes.
iii) Configuration.
b) Explain any one example with : [8]
i) Concurrent statements.
ii) Sequential statements.

SECTION - II

- Q7)** a) Explain the construction of depletion MOSFET. [8]
b) Explain voltage transfer characteristics of CMOS inverter. [10]

OR

- Q8)** a) Define : [8]
i) FAN-IN.
ii) FAN-OUT.
iii) Propagation delay.
iv) Power Dissipation w.r.t. CMOS also give its standard values.
b) Implement basic gates using CMOS. [10]

- Q9)** a) Compare PAL and PLA. [8]
b) Explain the architecture of complex programmable logic devices. [8]

OR

- Q10)** a) Explain the terms : [8]
i) Simulation.
ii) Synthesis.
iii) Place and Route.
iv) Boundry scan.
b) Give standard features of XILINX 4000 family. [8]

- Q11)** a) Write VHDL code for 2 bit adder. [8]
b) Write VHDL code for 8×8 RAM. [8]

OR

- Q12)** a) Write VHDL code for ALU. [8]
b) Write VHDL code for dividing the given number by 2. [8]

☒☒☒☒

Total No. of Questions : 12]

SEAT No.:

P1217

[Total No. of Pages : 3

[4164]-94
B.E. (Electrical)
HIGH VOLTAGE ENGINEERING
(2003 Pattern) (Elective - II) (Sem. - II)

Time : 3 Hours]

[Max. Marks : 100

Instructions to the candidates:

- 1) *Answer any one question from each unit.*
- 2) *Answer three questions from section-I and three questions from section-II.*
- 3) *Answers to the two sections should be written in separate books.*
- 4) *Neat diagrams must be drawn wherever necessary.*
- 5) *Figures to the right indicate full marks.*
- 6) *Use of logarithmic tables slide rule, mollier charts, electronic pocket calculator and steam tables is allowed.*
- 7) *Assume suitable data, if necessary.*

SECTION - I

Unit - I

- Q1)** a) Explain various primary and secondary ionization processes which causes breakdown of insulating gas when high voltage is applied to it. [10]
- b) In an experiment in a certain gas it was found that the steady state current is 5.5×10^{-8} Ampere at 8kV at a distance of 0.4cm between plane electrodes. Keeping the field constant and reducing the distance to 0.1cm results in current 5.5×10^{-9} Ampere. Calculate townsend's primary ionization coefficient α . [6]

OR

- Q2)** a) State and explain the Paschen's law. State its limitations. Show the graphical representation of variation of breakdown voltage with respect to $(p \times d)$ values, where p is gas pressure and 'd' is gap distance. [8]
- b) Discuss the process of breakdown in composite dielectrics. [8]

Unit - II

- Q3)** a) Explain the breakdown of solid dielectrics due to internal discharges.[8]
- b) Explain tracking which results in breakdown of solid dielectrics. State the precautions to be taken to avoid tracking. [8]

OR

P.T.O.

- Q4)** a) Explain the suspended particle theory and stressed oil volume theory for breakdown in liquid dielectrics. [12]
b) Explain the terms pure liquids and commercial liquids. [4]

Unit - III

- Q5)** a) Explain various ways to control over voltages due to switching. [10]
b) Define the following terms in connection with lightning arrester. [8]
i) Rated voltage.
ii) Spark over voltage.
iii) Residual voltage.

State the desired characteristics of a lightning arrester.

OR

- Q6)** a) Write note on insulation co-ordination. [10]
b) Write note on lightning phenomenon and development of overvoltages in power system. [8]

SECTION - II

Unit - IV

- Q7)** a) With neat sketch explain the construction and working of modified marx circuit for generation of impulse voltage. [8]
b) A 100kVA, 400V/250kV testing transformer has leakage reactance 8% and resistance 2% on 100kVA base. A cable has to be tested at 500kV using the above transformer as a resonant transformer at 50Hz. If the charging current of cable is 0.4 ampere at 500kV, find the series inductance required assume 2% resistance for the inductor to be used Neglect dielectric loss of the cable what will be input voltage to the transformer?[8]

OR

- Q8)** a) Explain the basic R, L, C circuit for impulse current generation prove that output current is exponentially decaying sine wave. [8]
b) A 12 stage impulse generator has 0.126 μ F capacitors. The wave front and wave tail resistances are 800 ohm and 5000 ohm respectively. If load capacitance is 1000 picofarad, find the front and tail times of the impulse wave produced. [8]

Unit - V

- Q9)** a) State and explain the various factors which affects the breakdown voltage in sphere gap arrangement. Explain the procedure to apply the correction factor for variation in ambient conditions. [8]
- b) With neat diagram explain construction and working of generating volt meter for measurement of high dc voltage state advantages of this method. [8]

OR

- Q10)** a) With neat diagram explain the method of measurement of high ac voltage using CVT. State the advantages and disadvantages of this method. [8]
- b) With neat sketch explain the method of measurement of impulse current using Rogowski coil with magnetic links. [8]

Unit - VI

- Q11)** a) Explain the method of measurement of capacitance and $\tan \delta$ of insulating material using high voltage Schering bridge draw its diagram. State the features of high voltage Schering bridge. [10]
- b) Write note on residual voltage test on lightning arrester. [8]

OR

- Q12)** a) State the various tests conducted on bushings. Explain how 'wet voltage withstand test' and 'Partial discharge test' conducted on it. [10]
- b) Write note on pollution test conducted on outdoor insulation. [8]



Total No. of Questions : 12]

SEAT No.:

P1218

[Total No. of Pages : 2

[4164]-96

B.E. (Electrical)

ANN AND ITS APPLICATIONS IN ELECTRICAL ENGG.

(2003 Pattern) (Elective - II) (Sem. - II)

Time : 3 Hours]

[Max. Marks : 100

Instructions to the candidates:

- 1) *Answers to the two sections should be written in separate books.*
- 2) *Neat diagrams must be drawn wherever necessary.*
- 3) *Figures to the right indicate full marks.*
- 4) *Assume suitable data, if necessary.*

SECTION - I

- Q1)** a) Explain Single Layer Neural Network with one output and two inputs. [6]
b) Enlist all Neural network transfer functions and their notations. [10]

OR

- Q2)** a) Describe biological inspiration in Artificial Neural Network. [8]
b) Explain different Layers of Neural Network with neat sketch. [8]
- Q3)** a) Describe the perceptron learning rule. [8]
b) What are paradigms of NN learning. [8]

OR

- Q4)** a) Explain feed forward neural network. [8]
b) Explain back propagation Neural Network. [8]
- Q5)** a) Explain adoptive learning rule. [9]
b) Explain delta rule in detail. [9]

OR

- Q6)** a) What is gradient descent rule? Explain. [9]
b) Explain Error based BP. [9]

P.T.O.

SECTION - II

- Q7)** a) What are the advantages of MLP over Single Layer Perceptron. [8]
b) Explain hebbian Neural Network. [8]

OR

- Q8)** a) What are the deficiencies of back-propagation algorithm. [8]
b) Explain pattern classification. [8]

- Q9)** a) Explain Kohonan Organizing maps. [8]
b) Explain Recurrent Network. [8]

OR

- Q10)** a) What is hopfield network? [8]
b) Explain ART. [8]

- Q11)** a) What is BAM? Explain Energy Function for a BAM. [9]
b) Apply feed forward approach for motion of End-Effector of robot manipulator with camera coordination. [9]

OR

- Q12)** Apply Neural Network to load shedding. Design Architecture. Find activation functions. [18]



Total No. of Questions : 12]

SEAT No. :

P1219

[Total No. of Pages : 2

[4164]-101
B.E. (Electronics)
COMPUTER NETWORKS
(2003 Pattern) (Sem. - I)

Time :3 Hours]

[Max. Marks :100

Instructions to the candidates:

- 1) *Answer any three questions from each section.*
- 2) *Answers to the two sections should be written in separate books.*
- 3) *Neat diagrams must be drawn wherever necessary.*
- 4) *Figures to the right indicate full marks.*
- 5) *Use of logarithmic tables slide rule, Mollier charts, electronic pocket calculator and steam tables is allowed.*
- 6) *Assume suitable data, if necessary.*

SECTION - I

- Q1)** a) Explain in detail the network software design issues. **[8]**
b) How do the layers of the TCP/IP model correlate to the layers of the ISO-OSI model. **[8]**

OR

- Q2)** a) Explain the ISO-OSI model used in computer networking. **[8]**
b) What is service primitive? Explain the four classes of service primitives with suitable examples. **[8]**

- Q3)** a) Draw and explain the Fiber Optic cable network used in computer networking. **[8]**
b) Explain the different wireless transmission techniques used in computer networking. **[8]**

OR

- Q4)** a) Explain the GEO, LEO & MEO satellite communication used for computer networking. **[8]**
b) Explain the concept of community Antenna Television and Internet over cable. **[8]**

P.T.O.

- Q5)** a) Explain the static and dynamic channel allocation in LAN and MAN. [9]
b) Explain the HDLC frame format and PPP frame format. [9]

OR

Q6) Write short notes on :

- a) Token bus versus Token Ring system. [6]
b) One Bit Sliding Window Protocol. [6]
c) Gigabit Ethernet [6]

SECTION - II

- Q7)** a) What are the design goals of network layer? Which services are provided by the network layer to the transport layer. [8]
b) Compare Dynamic and Static Routing. [8]

OR

- Q8)** a) What is remote procedure call in Transport layer? Explain in detail. [8]
b) Compare TCP and UDP protocols. [8]

- Q9)** a) Draw and explain the basic encryption model. Explain the concept of stream cipher. Also compare public & private key cryptography. [8]
b) Explain the concept of video on demand with a neat figure. [8]

OR

- Q10)** a) Explain the HTML programming and related TAGS in brief. Also explain the concept of socket programming. [8]
b) What is the importance of the Domain Name System? Explain the components of DNS system. [8]

- Q11)** a) What are the different types of IP address schemes? Explain static IP and dynamic IP allocating system. [10]
b) Draw and explain the TCP/IP protocol suite used for internet. [8]

OR

- Q12)** Write short notes on (Any Three) : [18]
a) IPv6
b) Masking and Subnet masking.
c) ICMP.
d) SNMP



Total No. of Questions : 12]

SEAT No. :

P1220

[Total No. of Pages : 3

[4164]-102
B.E. (Electronics)
ELECTRONIC PRODUCT DESIGN
(2003 Pattern) (Sem. - I)

Time :3 Hours]

[Max. Marks :100

Instructions to the candidates:

- 1) *Answer any three questions from each section.*
- 2) *Answers to the two sections should be written in separate books.*
- 3) *Neat diagrams must be drawn wherever necessary.*
- 4) *Figures to the right indicate full marks.*
- 5) *Use of electronic pocket calculator is allowed.*
- 6) *Assume suitable data, if necessary.*

SECTION - I

- Q1)** a) Explain the bathtub curve for reliability indicating all its regions, and discuss how failures are reduced prior to shipment of the product. [8]
- b) With the help of suitable example explain how ergonomic & aesthetic design considerations are satisfied. [8]

OR

- Q2)** a) What is the need of grounding? Explain the different grounding techniques with suitable sketch. Also indicate the applications of each type. [8]
- b) Explain the different noise coupling mechanisms & also comment how they can be minimized at board level. [8]

- Q3)** a) Discuss the recommended PCB design practices for [8]
- i) power supply & ground routing
 - ii) impedance matching & termination schemes.
- b) Calculate the resistance of a 10 mm long copper track with 1 mm width for a standard 35-micron copper clad laminate at 20°C. If the temperature of track increases to 50°C calculate the change in resistance.
(Assume $\rho = 1.724 \times 10^{-6} \Omega \cdot cm$) [5]
- c) Calculate the capacitance of two tracks running on opposite side of a double-sided PCB with 1 mm width, 100 mm length. The PCB laminate thickness is 1.4 mm & $\epsilon_r = 4.5$ [5]

P.T.O.

OR

- Q4)** a) Explain the precautions to be taken in routing clock signal on PCB. [6]
b) Explain the different considerations in high frequency circuits while designing PCB. [6]
c) Calculate the width of a track for microstrip geometry that gives $Z_0 = 50\Omega$ when the PCB laminate thickness is 1.6 mm, thickness of track 70 micron & the relative permittivity $\epsilon_r = 4.2$.
Comment on your answer. [6]

- Q5)** a) State the salient features & applications of DPO. [8]
b) Explain with schematic arrangement & justification, the type of instrument that you will use to find the faults in following cases – [8]
i) Microcontroller based circuit with a hairline short on two adjacent lines of data bus.
ii) Memory interface which is suspected to comply with set up and hold time requirements.

OR

- Q6)** a) Explain the significance & importance of following parameters while selecting a DSO – [8]
i) Memory Depth.
ii) Bandwidth.
iii) Sampling rate.
iv) Type of sampling.
b) Explain the use & limitations of following analysis with suitable example.
i) DC Analysis.
ii) AC Analysis. [8]

SECTION - II

- Q7)** a) State the different goals of software design. [6]
b) State the main features of a structured program. [4]
c) Discuss the process of developing software for a microcontroller-based system. [8]

OR

- Q8)** a) With the help of neat block diagram explain the different stages of software design. [8]
b) What are the considerations while selecting assembly language & high-level language? [6]
c) Explain the different types of compilers briefly. [4]

- Q9)** a) Explain the need of environmental test to be carried out on product. State the different tests to be carried out on mobile phone. [8]
b) Explain the importance of shielded room while conducting the EMI/EMC testing. [4]
c) Compare conducted EMI with radiated EMI. [4]

OR

- Q10)** a) Discuss the standard tests to be performed on new instruments for quality test. [8]
b) Explain the importance of the IEC standards. [4]
c) State the objectives of CE Marking. [4]
- Q11)** a) What is a documentation? Explain the different types of documentation. [8]
b) Give reasons – [8]
i) Bare board testing is essential for the PCB's with high track density.
ii) Paper phenolic laminates are not suitable for industrial products.

OR

- Q12)** a) With the help of suitable example explain how the following documents will be prepared – [8]
i) Product test specifications.
ii) Bill of material.
- b) Justify – [8]
i) Multilayer PCB must be used for the PLCC package, of IC's.
ii) Engineering Note book is a foundation of any engineering work.



Total No. of Questions : 12]

SEAT No. :

P1221

[Total No. of Pages : 3

[4164]-103
B.E. (Electronics)
ADVANCED POWER ELECTRONICS
(2003 Pattern) (Sem. - I)

Time :3 Hours]

[Max. Marks :100

Instructions to the candidates:

- 1) *Answer the three questions from Section I and three questions from Section II.*
- 2) *Answers to the two sections should be written in separate books.*
- 3) *Neat diagrams must be drawn wherever necessary.*
- 4) *Figures to the right indicate full marks.*
- 5) *Yours answers will be values as a whole.*
- 6) *Use of logarithmic tables, slide rule, Mollier charts, electronic pocket calculator and steam tables is allowed.*
- 7) *Assume suitable data, if necessary.*

SECTION - I

- Q1)** a) Explain the effect of source inductance on the performance of single phase full converter with waveforms and analysis. **[10]**
- b) Draw the circuit diagram of a three phase semi-converter feeding a highly inductive load (ripple-free) and the following waveforms for $\alpha = 30^\circ$. **[8]**
- i) Supply phase voltages.
 - ii) Supply line voltages.
 - iii) Output voltage.

OR

- Q2)** a) What are dual converters? With the help of a neat circuit diagram and relevant waveforms, explain the operation of a single-phase circulating mode dual converter. **[12]**
- b) Compare circulating and non-circulating current mode dual converters. **[6]**
- Q3)** a) With the help of a neat circuit diagram, relevant waveforms and mode equivalent circuits, explain the operation of a three-phase, 180° mode, voltage source inverter feeding a balanced, star connected resistive load. **[8]**

P.T.O.

- b) A three phase inverter has a Y-connected load of $R = 5\ \Omega$ and $L = 23$ mH. The inverter frequency is $f_o = 60\ \text{Hz}$ and the dc input voltage is $V_s = 220\text{V}$. Determine. [8]
- the r.m.s. line to line voltage V_L
 - the r.m.s. phase voltage V_p
 - the r.m.s. line voltage V_{L1} at the fundamental frequency
 - the r.m.s. phase voltage at the fundamental frequency V_{p1}

OR

- Q4)** a) What are the different output voltage control and harmonic reduction techniques in inverters. [6]
- b) Explain in detail the MMSR (multiple pulse modulation with selective reduction of harmonics) technique. [10]

- Q5)** Enlist the different power factor improvement techniques. Explain the S.A.C. method of P.F. improvement with the help of circuit diagram, waveforms and mathematical analysis. Compare this with active wave shaping techniques. [16]

OR

- Q6)** a) What is the need for resonant converter? Explain zero voltage switching (ZVS) resonant converter with circuit diagram and waveforms. [8]
- b) Give the requirements of sensing circuit and explain how will you sense the following : [8]
- DC current and
 - AC current.

SECTION - II

- Q7)** a) The speed of a separately excited dc motor is controlled by a single phase semi converter. The field current, which is also controlled by a semiconverter is set to the maximum possible value. The a.c. supply voltage to the armature and field converters is one phase, 208V, 60Hz the armature resistance is $R_a = 0.25\ \Omega$, the field resistance is $R_f = 147\ \Omega$ and the motor voltage constant is 0.7032 V/A rad/sec. The load torque is $T_L = 45\text{N-M}$ at 1000 rpm. The viscous friction and no load losses are negligible. The inductances of the armature and field circuits are sufficient enough to make the armature and field currents continuous and ripple free. Determine [12]

- i) the field current I_f
 - ii) the delay angle of the converter in the armature circuit α_a
 - iii) the input power factor (PF) of the armature circuit converter.
- b) With neat sketch explain variable reluctance stepper motor. [6]

OR

- Q8)** a) Explain the working of a 1-phase dual converter fed separately excited d.c. motor drive. [10]
- b) Compare servomotors with conventional DC motors and stepped motors. [8]
- Q9)** a) With the help of neat circuit diagram and appropriate torque-speed curves, explain the slip power recovery scheme for speed control of induction motors. [10]
- b) Explain the following motor protections. [6]
- i) Field failure in DC motors.
 - ii) Overload protections.

OR

- Q10)** a) With the help of a circuit diagram and the motor torque-speed characteristic, explain stator voltage speed control of induction motors. [8]
- b) With the help of a circuit diagram explain the regenerative braking technique for DC motors. [8]
- Q11)** a) What is meant by voltage unbalance and voltage fluctuation in power systems? What are their causes and their effects on the performance of the power system. [10]
- b) Explain briefly the need of energy audit in industries. [6]

OR

- Q12)** Enumerate the different types of short duration power line voltage disturbances and explain any two in detail. [16]



Total No. of Questions : 12]

SEAT No. :

[Total No. of Pages : 2

P1222

[4164]-104
B.E. (Electronics)
VLSI DESIGN
(2003 Pattern) (Sem. - I)

Time :3 Hours]

[Max. Marks :100

Instructions to the candidates:

- 1) *Answers to the two sections should be written in separate books.*
- 2) *Neat diagrams must be drawn wherever necessary.*
- 3) *Figures to the right indicate full marks.*
- 4) *Use of logarithmic tables, slide rule, Mollier charts and steam tables is allowed.*
- 5) *Assume suitable data, if necessary.*

SECTION - I

- Q1)** a) Write VHDL code for a bidirectional 4 bit synchronous counter with mode control. [8]
b) Explain the VLSI design flow from design entry to Downloading. [8]

OR

- Q2)** a) Differentiate between : [8]
i) Function Vs Procedure.
ii) Signal Vs Variable.
b) Write a VHDL code for 4 bit shift register. [8]

- Q3)** a) Draw state diagram and write VHDL code for traffic light controller controlling traffic for two lane intersection. [10]
b) Compare various FSM state encoding techniques. Which is the most suitable for FPGA's Why? [8]

OR

- Q4)** a) Draw state diagram and write VHDL code for lift controller. [10]
b) What is metastability? State the solutions. Explain any one solution in detail. [8]

P.T.O.

- Q5)** a) Draw block diagram and explain architecture of CPLD. [10]
b) Write four specifications of CPLD and FPGA each. [6]

OR

- Q6)** a) Draw block diagram and explain architecture of FPGA. [10]
b) Differentiate PLD, CPLD and FPGA. [6]

SECTION - II

- Q7)** a) Explain global and switch box routing. [8]
b) Explain the concept of EMI immune design. [8]

OR

- Q8)** a) Draw circuit diagram and explain the MOS static RAM cell. [8]
b) Explain off chip connection and I/O architecture. [8]

- Q9)** a) Explain static and dynamic power dissipation in CMOS inverter. [10]
b) What is technology scaling? With merits and demerits explain any two methods of technology scaling. [8]

OR

- Q10)** a) Explain in detail transfer characteristics of CMOS inverter. [10]
b) What is transmission gate? Explain implementation of 2:1 multiplexer using transmission gate. [8]

- Q11)** a) Explain stuck at fault methods. [8]
b) Explain TAP controller with its state diagram. [8]

OR

- Q12)** a) What is the need of design for testability? Explain in short different types of faults. [8]
b) What is need of boundary scan? Give suitable examples. [8]

* * *

Total No. of Questions : 12]

SEAT No. :

P1223

[Total No. of Pages : 2

[4164]-106

B.E. (Electronics Engineering)

PROCESS INSTRUMENTATION

(2003 Pattern) (Elective - I) (Sem. - I)

Time :3 Hours]

[Max. Marks :100

Instructions to the candidates:

- 1) *Solve Q.1 or Q.2, Q.3 or Q.4, Q.5 or Q.6 from Section I & solve Q.7 or Q.8, Q.9 or Q.10, Q.11 or Q.12 from Section II.*
- 2) *Answer three questions from Section - I and three questions from Section - II.*
- 3) *Answers to the two sections should be written in separate books.*
- 4) *Neat diagrams must be drawn wherever necessary.*
- 5) *Figures to the right indicate full marks.*
- 6) *Use of logarithmic tables slide rule, Mollier charts, electronic pocket calculator and steam tables is allowed.*
- 7) *Assume suitable data, if necessary.*

SECTION - I

Q1) a) Draw the block diagram of control system. Explain it with suitable example. [8]

b) Explain different instrumentation standard signals. [8]

OR

Q2) a) Define the term transducer. Give classification of transducers with suitable example. [8]

b) Explain electromagnetic flow meter in detail. [8]

Q3) a) List & explain factors for selection of control valve. [8]

b) Explain electropneumatic actuator in detail. [8]

OR

Q4) a) Explain electronic PID controller in detail. [8]

b) Explain hydraulic proportional plus integral controller. [8]

Q5) a) Define the term automatic control system. Compare open loop and closed loop control systems with suitable examples. [10]

b) With suitable example explain feed forward control system. [8]

P.T.O.

OR

- Q6)** Write a short note on : [18]
- a) Adaptive control system.
 - b) Statistical process control.
 - c) Self tuning controller.

SECTION - II

- Q7)** a) Explain modeling and simulation of temperature process system. [8]
b) Describe model predictive control in detail. [8]

OR

- Q8)** a) Write a short note on internal model control. [8]
b) Describe in detail optimization of feed forward control system. [8]
- Q9)** a) Define the term PLC. Draw & explain architecture of PLC. [8]
b) Compare relay logic controller and programmable logic controller. [8]

OR

- Q10)** a) Define the term ladder diagram. Draw and explain ladder diagram for bottle filling plant. [8]
b) List the different specifications of PLC. Which different symbols are used in ladder diagram programming. [8]
- Q11)** a) Draw and explain in detail supervisory control system. [10]
b) Explain in detail SCADA. [8]

OR

- Q12)** Write a short note on : [18]
- a) Square root extractor.
 - b) Alarm Annunciator.
 - c) Recorders.

Total No. of Questions : 12]

SEAT No. :

P1224

[Total No. of Pages : 3

[4164]-107

B.E. (Electronics Engineering)

ADVANCED DIGITAL SIGNAL PROCESSING

(2003 Pattern) (Elective - I) (Sem. - I)

Time :3 Hours]

[Max. Marks :100

Instructions to the candidates:

- 1) *Answer three questions from Section - I and three questions from Section - II.*
- 2) *Answers to the two sections should be written in separate books.*
- 3) *Neat diagrams must be drawn wherever necessary.*
- 4) *Figures to the right indicate full marks.*
- 5) *Use of logarithmic tables slide rule, Mollier charts, electronic pocket calculator and steam tables is allowed.*
- 6) *Assume suitable data, if necessary.*

SECTION - I

- Q1)** a) Explain decimation by factor D. Write expression for decimated signal at the output. **[6]**
- b) Design a Linear Phase FIR filter for specifications : **[12]**
- | | | |
|--------------------|---|-----------------------|
| Sampling frequency | - | 8000 Hz |
| Passband | - | $0 \leq F \leq 75$ |
| Transition band | - | $75 \leq F \leq 80$ |
| Stop band | - | $80 \leq F \leq 4000$ |
| Passband ripple | - | $\delta_1 = 10^{-2}$ |
| Stopband ripple | - | $\delta_2 = 10^{-4}$ |

OR

- Q2)** a) Design a 3 stage decimator that down samples an audio signal by a factor of 96 with specifications: $F_s = 96$ kHz. Highest frequency of interest in data 450 Hz. **[10]**
- $\delta_p = 0.01$ $\delta_s = 0.001$.
- b) Explain in detail DAC in compact *hi-fi* system. **[4]**
- c) Explain random process. **[4]**

P.T.O.

- Q3)** a) What is need of adaptive filters. Explain adaptive filters as noise cancellation. [8]
b) Explain LMS adaptive algorithms. [8]

OR

- Q4)** a) How is the effect of echo minimised in a telephone communication. [8]
b) Explain adaptive filtering of Ocular artifacts from the human EEG. [8]

- Q5)** a) Consider the ARMA Process generated by the difference equation. [12]
 $x(n) = 1.6x(n-1) - 0.63x(n-2) + w(n) + 0.9w(n-1)$
i) Determine the system function of the whitening filter & its poles & zeros.
ii) Determine the power density spectrum of $\{x(n)\}$.
b) Explain Lattice structure in brief. [4]

OR

- Q6)** a) Explain Levinson-Durbin algorithm. [10]
b) Explain rational power spectra in detail. [6]

SECTION - II

- Q7)** a) Write short notes on Welch method. [8]
b) Explain how the DFT is used for finding power spectrum estimation. [8]

OR

- Q8)** a) Write short notes on Bartlett window method. For power spectrum estimation. [8]
b) Explain the estimation of auto correlation & power spectrum of random signal. [8]

- Q9)** a) What is the need of DSP processor & what are its desirable features. [8]
b) Draw the Architecture of typical DSP processor & explain in short. [10]

OR

- Q10)** a) Explain in brief the following functional units of DSP processor. [10]
i) Barrel shifter.
ii) DAGS.
iii) MAC.
b) What is effect of coefficient quantization of FIR and IIR filters. [8]

- Q11)** a) Explain the concept of subband coding of speech/Audio signal. [8]
b) Write short notes on Speech Analysis. [8]

OR

- Q12)** a) Explain the following terms : [6]
i) Speech synthesis.
ii) Speech recognition.
iii) Speech coding.
- b) Explain in brief with block diagram the digital signal processing of Audio signals. [10]

* * *

Total No. of Questions : 12]

SEAT No. :

P1225

[Total No. of Pages : 3

[4164]-109

B.E. (Electronics Engineering)

SOFTWARE ENGINEERING

(2003 Pattern) (Elective - I) (Sem. - I)

Time :3 Hours]

[Max. Marks :100

Instructions to the candidates:

- 1) *Answer any three questions from each section.*
- 2) *Answers to the two sections should be written in separate answer sheet.*
- 3) *Neat diagrams must be drawn wherever necessary.*

SECTION - I

- Q1)** a) Explain with neat diagram incremental models and state it's advantages and disadvantages. [7]
- b) What is software process and what are the generic framework activities that are present in every software process? [6]
- c) Write short notes on : Unified Process. [5]

OR

- Q2)** a) Explain the advantages and disadvantages of spiral process model over waterfall process model. Which process model is better and why? [7]
- b) Explain in detail all the levels of CMMI with key process area. What is Process Assessment? Explain with suitable diagram? [6]
- c) What is Software Engineering? What are the characteristics of Software? [5]

- Q3)** a) With a neat diagram and example explain Hately-Pirbhai modeling. What is the role of architecture flow diagram? [8]
- b) What are the core principles of software Engineering practices? [8]

OR

- Q4)** a) Explain the importance of system modeling. Explain the factors that are considered to create system model. [8]
- b) What three domains are considered during analysis modeling? [8]

P.T.O.

- Q5)** a) Specify the notations used in Activity Diagram. Draw a activity diagram for the scenario: “Withdraw the amount from ATM”. [8]
b) Explain the steps required to initiate requirements gathering. [8]

OR

- Q6)** a) Consider the system: Online digital Library. Draw a complete use case diagram for the given system. [8]
b) Describe the primary differences between the structured analysis and object-oriented analysis. [8]

SECTION - II

- Q7)** a) What is Interface? What is the role of interface in a class-based component design? [9]
b) What is software Architecture? What is the role of interfaces in a class based component level design? [9]

OR

- Q8)** Explain in brief (any 4) : [18]
a) Patterns.
b) Design classes.
c) Data-centered Architecture.
d) Data-flow Architecture.
e) Design evaluation.
f) Modularity.

- Q9)** a) What is Software Quality? What are the factors affecting software Quality? What are the mechanisms to address quality software? [8]
b) What is Metrics? Explain Metrics for software Productivity and Quality. [8]

OR

- Q10)** a) What is the difference between measure and metric? What are the attributes of effective software metric? [8]
b) What are the phases of software project planning and management? [8]

- Q11)** a) Explain reverse engineering and forward engineering with suitable example. [8]
- b) Explain why software sizing plays an important role in estimation of cost. [8]

OR

- Q12)** a) Explain SCM (Software configuration management). What are the processes of SCM. [8]
- b) What do you mean by decomposition techniques in software engineering? [8]



Total No. of Questions : 12]

SEAT No. :

P1226

[Total No. of Pages : 2

[4164]-110

B.E. (Electronics Engineering)

ELECTRONICS MEASUREMENT SYSTEMS

(2003 Pattern) (Sem. - II)

Time :3 Hours]

[Max. Marks :100

Instructions to the candidates:

- 1) *Answers to the two sections should be written in separate books.*
- 2) *Neat diagrams must be drawn wherever necessary.*
- 3) *Figures to the right indicate full marks.*

SECTION - I

Q1) a) Why calibration is required? With the help of neat diagram, explain:[10]

- i) Direct comparison calibration set up.
- ii) Indirect comparison calibration set up.
- iii) Traceability.

b) With the help of block diagram, explain digital LCR meter. [8]

OR

Q2) a) Draw block diagram of digital multimeter and explain its operation. [8]

b) Explain with the block diagram, true rms voltmeter. [8]

c) W.r.t. DMM explain 'Auto ranging'. [2]

Q3) a) Explain with the help of block diagram period measurement of frequency counter. [8]

b) With the help of block diagram explain the ratio measurement. [8]

OR

Q4) a) Explain how to carry high frequency measurement using frequency counter. [8]

b) Write detailed specification of universal frequency counter. List various errors in frequency measurement. [8]

P.T.O.

- Q5)** a) What is Wave Analyzer? With the help of block diagram explain Heterodyne Wave Analyzer. [8]
b) Compare Spectrum Analyzer with Logic Analyzer. [8]

OR

- Q6)** a) Draw and explain FFT analyzer with the help of block diagram. [8]
b) Explain continuous storage mode and transitional storage mode of logic analyzer. [8]

SECTION - II

- Q7)** a) Define selectivity and sensitivity. Describe two methods for measuring sensitivity of receiver. [10]
b) Explain in brief selectivity measurement methods. [8]

OR

- Q8)** a) Compare Scalar network analyzer with vector network analyzer. [10]
b) How S-parameter measurement is done with the help of Network Analyzer. [8]

- Q9)** a) Explain various triggering modes used in digital storage oscilloscope. [8]
b) State various advantages and applications of digital storage oscilloscope. [8]

OR

- Q10)** a) Explain following modes of operation of digital storage oscilloscope: [8]
i) Roll mode,
ii) Store mode.
b) Explain the need of Sampling Oscilloscope. What are the advantages of Sampling Oscilloscope. [8]

- Q11)** a) Explain with the diagram, how Virtual Instrumentation is used for PSK transmission system? [8]
b) Draw block schematic of virtual front panel and explain it. [8]

OR

- Q12)** a) Explain computer controlled test measurement with a suitable example. [8]
b) Write short note on : Lab View. [8]



Total No. of Questions : 12]

SEAT No. :

P1227

[Total No. of Pages : 3

[4164]-111
B.E. (Electronics)
MANAGEMENT INFORMATION SYSTEM
(2003 Pattern) (Sem. - II)

Time :3 Hours]

[Max. Marks :100

Instructions to the candidates:

- 1) *Answer any three questions from each section.*
- 2) *Answers to the two sections shall be written in separate books.*
- 3) *Neat diagrams must be drawn wherever necessary.*
- 4) *Figures to the right indicate full marks.*
- 5) *Assume suitable data, if necessary.*

SECTION - I

- Q1)** a) What do you understand by the term “Convergence of Technology”? What are the implications for Electronics Industry. **[10]**
- b) Describe the structure, components and nature of information processing that characterize a MIS. **[8]**

OR

- Q2)** a) Explain business compulsion for shift in business strategy from that of productivity maximization and cost reduction to that of “business competitive advantage” through strategic parity. Further explain why it is important to achieve competitive advantage with integrity. **[10]**
- b) What do you understand by the term ‘information avalanche’? Discuss the implications of the convergence technology for the “information avalanche”. **[8]**
- Q3)** a) Define Information Integrity, Information integrity risk. **[8]**
- b) Discuss uncertainties present in business process IS view at various levels? In the process explain how these uncertainties render flexible business information decision with risk of distortion and noise and, therefore, loss of Information integrity. **[8]**

OR

P.T.O.

- Q4)** a) Explain why there is a shift from collective decision to individual decision with example. [8]
b) Why is business process in a complex and changing environment an open system. [8]
- Q5)** a) Differentiate complex error from a simple error. Preferably give an example. [8]
b) “Information should be seen as a composite good; a bundle of interrelated attributes. Given that information is for use, one attribute is relevance, i.e., usefulness, second is usable information, and third is integrity, i.e., freedom from distortion and noise, What do you understand by this? Explain briefly. [4]
c) Compare the terms ‘productivity’ and ‘efficiency’ in a competitive environment. [4]

OR

- Q6)** a) What is the significance of “System Dynamics” methodology in studying the complex system failures? Explain with an example. [8]
b) Define any three of the following System Dynamic variables. [8]
i) Rate variable.
ii) Level variable.
iii) Parameters and input variable.
iv) Supplementary variables.
v) Auxiliary variable.

SECTION - II

- Q7)** a) What do you understand by the terms : [8]
i) Closed system and Open system.
ii) Closed loop and Open loop.
b) Dynamic decision stages processing maximal information for business IS view are information origination processes. List and briefly describe elements of the information origination process. [8]

OR

- Q8)** a) “Existing practice is to verify data for its integrity. However, given the reality of ever changing environment, requirement for the improved decision-making is to view information as a composite good of interrelated attributes, namely, usefulness, usability and integrity.” [8]
b) Define attributes of Information Integrity. [8]

Q9) a) Equation (1) gives Cost benefit Analysis Equation of Information Integrity.
$$\Delta IU(I)|Si = \{[\alpha(I) \times \beta(I) \times IUUB(I)] Si\} \times \{A(I)|Si\} - [COSTOI(I)|Si + COSTANALY \{A(I)\} | Si + COSTOPPORT \{A(I)\}|Si] \rightarrow \text{Equation (1).}$$

Explain this equation and its significance for the objective of business competitive advantage. [10]

- b) Write short notes on following : [8]
- i) Implications of Systems Dynamics for I*I Technology Development System.
 - ii) Significance of “Feedback” in the Information Integrity Development System.

OR

- Q10)** a) Write short notes on : [8]
- i) Acquisition Cycle under the I*I technology development system.
 - ii) Utilization cycle under information Integrity development system.
- b) What is “Usefulness-Usability-Integrity paradigm”? What is its main implication? [10]

- Q11)** a) Give cost benefit analysis equation of information integrity and explain each terms of the equation. [8]
- b) Define components of I*I risk. [8]

OR

- Q12)** a) Compare Traditional IS, Quality IS and Integrity IS with respect to any three of the following parameters. [8]
- i) Parameter: Paradigm – *System Complexity* factor,
 - ii) Parameter: Paradigm – *Information* factor,
 - iii) Parameter: Paradigm – *Risk* factor,
 - iv) Parameter: Paradigm – *Value* factor,
 - v) Parameter: Process factor of strategy.
- b) Explain a systems view of a design basis for the “Information Integrity Technology System” leading to Integrity Information system. [8]

* * *

Total No. of Questions : 12]

SEAT No. :

P1228

[Total No. of Pages : 2

[4164]-112
B.E. (Electronics)
BIOMEDICAL ELECTRONICS
(2003 Pattern) (Sem. - II)

Time :3 Hours]

[Max. Marks :100

Instructions to the candidates:

- 1) *Answer 3 questions from each section.*
- 2) *Answers to the two sections should be written in separate books.*
- 3) *Neat diagrams must be drawn wherever necessary.*
- 4) *Figures to the right indicate full marks.*

SECTION - I

- Q1)** a) Explain with block schematic man-instrument system. **[9]**
b) Explain the function of Biosignal transducer, also state the drawbacks of Biosignal transducer. **[9]**

OR

- Q2)** a) Name the different types of Electrodes? Explain any two in detail. **[9]**
b) Draw the fiber optic sensor for temperature measurement. Explain its working. **[9]**

- Q3)** a) Explain the cardiovascular circulation with diagram. **[8]**
b) What is systole and dystole pressure. Explain the pressure variations as a function of time. **[8]**

OR

- Q4)** a) Explain various heart sounds generated in mechanical pumping activity of heart with their frequencies. **[8]**
b) Explain the electroconduction system of heart. **[8]**
- Q5)** a) Draw and explain the protection circuit for ECG amplifier & describe its working. **[8]**
b) Give classification of different ECG lead configuration. **[8]**

P.T.O.

OR

- Q6)** a) Describe operation of DC defibrillator with circuit diagram and waveform. [8]
b) Explain the Grounding and Shielding techniques. [8]

SECTION - II

- Q7)** a) Draw the diagram of colorimeter? Explain its working in detail. [9]
b) Explain the working of spectrophotometer with necessary diagram. [9]

OR

- Q8)** a) Explain the working of Blood Gas Analyzer with necessary diagram. [9]
b) Draw the Block diagram of Non Fade CRO. Explain its working. [9]
- Q9)** a) Draw the 10:20 EEG electrode placement system. Explain in detail. [8]
b) Explain electroencephalography with necessary waveform. [8]

OR

- Q10)** a) Explain the EEG patterns in [8]
i) Alert state
ii) Drowsiness
iii) Theta and beta waves.
b) Explain various EEG waveforms with their frequency and its significance. [8]
- Q11)** a) Explain the working of CT Scan Machine with neat diagram. [8]
b) Draw the Block diagram of MRI machine? Explain in detail. [8]

OR

- Q12)** a) Explain the application of laser in medicine. [8]
b) Explain the ultrasonic doppler machine. [8]



Total No. of Questions : 12]

SEAT No. :

P1232

[Total No. of Pages : 3

[4164]-121
B.E. (E & TC)
COMPUTER NETWORKS
(2003 Pattern) (Sem. - I)

Time :3 Hours]

[Max. Marks :100

Instructions to the candidates:

- 1) *Answer 3 questions from Section I and 3 questions from Section II.*
- 2) *Answers to the two sections should be written in separate books.*
- 3) *Neat diagrams must be drawn wherever necessary.*
- 4) *Figures to the right indicate full marks.*
- 5) *Use of logarithmic tables, slide rule, Mollier charts, electronic pocket calculator and steam tables is allowed.*
- 6) *Assume suitable data, if necessary.*

SECTION - I

- Q1)** a) Compare OSI and TCP/IP network Reference models and explain what are vulnerabilities of TCP/IP. **[8]**
- b) Explain in brief Hardware address, IP address and port address. **[4]**
- c) Explain structure of layer-2 switch and router in detail. **[4]**

OR

- Q2)** a) What is ADSL technology? Also define VDSL, HDSL, SDSL & DSLAM. **[8]**
- b) Explain Unicasting, Broadcasting, Multicasting and point to point Networks. **[4]**
- c) Explain the physical layer of 802.11 Wireless network. **[4]**
- Q3)** a) What is dial up modem technology? Draw and explain the block diagram of Dial up modem. Give the specification of typical Dial-up modem. **[8]**
- b) What is Shannon's channel capacity theorem? What is the maximum data rate for a telephone line with BW 3.6 kHz and 35db SNR? **[4]**
- c) Compare twisted pair cable, coaxial cable, fiber optic cable. What is single mode and Multi-mode fiber? **[4]**

OR

P.T.O.

- Q4)** a) Explain the cable TV network. Also explain in brief how video signal and Internet data can be send over the same cable. Compare DSL vs Cable modem technology. [8]
- b) Explain bandwidth division in ADSL and the Discrete Multitone modulation technique used in ADSL. Also give the bit rate of other DSL technologies. [4]
- c) What type of switching takes place in ATM networks? Compare with IP network based Switching. [4]
- Q5)** a) What are the functions of Data link layer protocol? Draw & Explain PPP frame format in detail. Explain the Use of PPP in dial-up internet communication? [6]
- b) Explain Selective Repeat ARQ protocol. What are different framing techniques? [6]
- c) Explain Bit stuffing in detail? Explain what is GBN ARQ technique. [4]
- d) What is HDLC protocol? [2]

OR

- Q6)** a) Consider a 64 Kbps geostationary satellite channel is used to send 512 byte data frames in one direction, with a very short acknowledgement coming back the other way. What is the maximum throughput for window size of 1, 7, 15 and 127 using sliding window protocol? [4]
- b) What is hamming coding? How it is useful in computer Networking?[4]
- c) Explain CSMA/CD flowchart in detail. What is Slotted ALOHA. [6]
- d) Explain 802.3 MAC frame. What is PAD field? [4]

SECTION - II

- Q7)** a) In token bucket system calculate the required parameters in following two different cases. [4]
- i) Computer system on a 6 Mbps network is regulated by a token bucket is filled at a rate of 2 Mbps. It is initially filled to capacity 12 Mbit. How long can the computer system transmit at full rate of 6 Mbps.
- ii) Network processing computer on a 10 Mbps network is regulated by a token bucket. It is initially filled to capacity 18 Mbit. Time taken by Network processing computer to transmit at full rate of 10 Mbps is 3 sec. At what rate the token bucket should be filled up?
- b) What is routing and routed protocol? [4]
- c) Explain the Distance vector routing in detail. Compare with Link state routing. [4]
- d) Compare static and dynamic routing algorithm with suitable example.[4]

OR

- Q8)** a) What are different transport service primitives? Explain QoS at transport layer. Define delay, congestion, throughput & Jitter. [8]
- b) Consider a TCP connection is transferring a file of 7000 bytes. The first byte is numbered 11001, what are the sequence numbers for each segment if data are sent in five segments, each carrying 1000 bytes? Draw UDP header format. [2]
- c) Draw and explain the TCP header in detail. [4]
- d) Compare TCP Vs UDP. [2]
- Q9)** a) Explain the RSA algorithm with suitable example. [4]
- b) What is sockets address? Write Socket address of web server and FTP server for class-A, class-B & Class-C Private IPv-4 address. [4]
- c) What is DNS? What are three main components of DNS? In your organization can DNS server run on proxy server? Justify it. [4]
- d) What is the function of SMTP and POP-3 protocols in Email system? What protocol is used to secure Email communication? [4]

OR

- Q10)** a) Define Cryptanalysis, Cryptology, Substitution cipher and Transposition cipher. [4]
- b) Explain the DES algorithm. What is triple DES? [4]
- c) What is “WWW”? What is HTML? How to write web page in HTML? [4]
- d) What is Video on Demand system? [4]
- Q11)** a) Draw & explain IPv6 header. [4]
- b) Compare IP-v4 versus IP-v6. [4]
- c) Explain Telnet, FTP, SNMP and Traceroute in TCP/IP. [4]
- d) Explain ARP, RARP and IGMP in detail. [6]

OR

- Q12)** a) What are the different types of public & private IP addresses according to IANA? Give multicasting IP address range & write its applications? What is loopback IP address? [8]
- b) Explain ICMP protocol and PING options in detail. [4]
- c) Explain TFTP, BOOTP, NFS & RPC briefly. [6]



Total No. of Questions : 12]

SEAT No. :

P1233

[Total No. of Pages : 3

[4164]-122
B.E. (E & TC)
VOICE NETWORK
(2003 Pattern) (Sem. - I)

Time :3 Hours]

[Max. Marks :100

Instructions to the candidates:

- 1) *Answer 3 questions from each section.*
- 2) *Answer 3 questions from Section I and 3 questions from Section II.*
- 3) *Answers to the two sections should be written in separate books.*
- 4) *Neat diagrams must be drawn wherever necessary.*
- 5) *Figures to the right indicate full marks.*
- 6) *Assume suitable data, if necessary.*
- 7) *All questions are compulsory.*

SECTION - I

- Q1)** a) Explain the memory controlled time division time switching with neat diagram. **[8]**
- b) List at least six differences between the postal and telephone systems and bring out the analogy between S&F and circuit switched connections. **[6]**
- c) What are the differences between common control and direct control? **[4]**

OR

- Q2)** a) What are the various signaling tones received by the subscriber and exchange while setting up the telephone call? State the typical specifications for these tones. **[8]**
- b) Explain different modes of configuration of Dual Processor architecture. **[6]**
- c) Given that MTBF = 3000 Hrs and MTTR = 4 Hrs. Calculate the unavailability for single and dual processor system. The life of Exchange is 30 years. **[4]**
- Q3)** a) Differentiate between loss system & delay system. Explain lost call cleared model in traffic engineering. **[6]**
- b) Define and explain the “Erlang C” formula for blocking probability. **[6]**

P.T.O.

- c) Define Grade of service & blocking probability. [4]

OR

- Q4)** a) Following data is collected to estimate voice traffic during 2 hours period.

Call No.	Call duration in seconds
1	85
2	89
3	76
4	110
5	92
6	68
7	54

Calculate the traffic intensity in Erlangs, CS and CCS. [6]

- b) Describe different traffic measurements units in telecommunication network. [6]
c) Define the significance of B and D channel in ISDN. [4]

- Q5)** a) With the help of neat diagram explain different services supported by ISDN. [8]

- b) Describe Non-voice and value added services provided by ISDN. [8]

OR

- Q6)** a) Explain BRI & PRI architecture of ISDN. [8]

- b) Explain in detail the architecture of ISDN & its objectives. [8]

SECTION - II

- Q7)** a) With the help of neat diagram explain GSM architecture and its evolution. [6]

- b) Explain different interference reducing mechanism in GSM. [6]

- c) Enlist Speech Codec attributes and describe Half Rate and Full Rate codec used in GSM. [6]

OR

- Q8)** a) Explain with the flow diagram and various channel association to originate a call in GSM network. [6]

- b) Describe in detail various techniques in GSM to enhance spectral efficiency. [6]

- c) Explain various data services in GSM system. [6]

- Q9)** a) Draw the architecture of IS-95 system and explain in detail various functional entities. [8]
b) “CDMA is having better security than GSM”. Explain. [8]

OR

- Q10)** a) Describe physical and logical channel of IS-95. [8]
b) Compare IS-95 and CDMA-2000 system in detail. [8]
- Q11)** a) Explain in detail various low level protocol used in IP technology. [8]
b) Describe speech coding technique i.e. ADPCM in detail. [8]

OR

- Q12)** a) Explain in detail DTMF generation and detection. [8]
b) Describe MEGACO and H.248 in detail. [8]

* * *

Total No. of Questions : 12]

SEAT No. :

P1234

[Total No. of Pages : 3

[4164]-123
B.E. (E & TC)
ELECTRONIC PRODUCT DESIGN
(2003 Pattern) (Sem. - I)

Time :3 Hours]

[Max. Marks :100

Instructions to the candidates:

- 1) *Answer three questions from Section I and three questions from Section II.*
- 2) *Attempt not more than six questions of which at least three questions must be from each section.*
- 3) *Answers to the two sections should be written in separate books.*
- 4) *Neat diagrams must be drawn wherever necessary.*
- 5) *Figures to the right indicate full marks.*
- 6) *Use of electronic pocket calculator is allowed.*
- 7) *Assume suitable data, if necessary.*

SECTION - I

- Q1)** a) With the help of block schematic explain in brief the 'concept of product development'. **[6]**
- b) Explain in brief the different types of product requirements with appropriate examples. **[8]**
- c) Classify electronic product on the basis of temperature range, reliability and cost. **[4]**

OR

- Q2)** a) With the help of block schematic explain in brief the factors affecting reliability of electronic product. **[6]**
- b) Explain the following terms in context with reliability of an electronic product. **[8]**
- i) MTTF
 - ii) MTBF
 - iii) MTTR
 - iv) Failure Rate
- c) What is the need of tranzorb? Explain with simple circuit diagram the working principle of tranzorb. **[4]**

P.T.O.

- Q3)** a) Draw a sketch of front panel of a laboratory function generator and explain how ergonomic and aesthetic design considerations are taken care of the same. [8]
- b) Explain the factors affecting packaging with proper examples. [8]

OR

- Q4)** a) What is the need of grounding? Explain in brief different types of grounding with suitable sketches. [8]
- b) What is the need of shielding? What are different types of shielding? Explain each type in brief with suitable sketches. [8]
- Q5)** a) Explain the precautions specially taken for analog circuit and digital circuit PCB Design. [8]
- b) What is bare board testing? Explain in brief the commonly used methods of BBT. [8]

OR

- Q6)** a) For 35 micron copper clad laminate, what will be the value of resistance of 1 mm wide and 20 cm long track (Assume resistivity of copper is 1.724×10^{-6} Ohm-cm). For the same clad of copper, what will be the inductance of 20 cm long track on PCB having width 0.7 mm. [8]
- b) Explain the mechanism of generation and prevention methods for the following phenomena in high-speed PCB designs. [8]
- i) Cross talk.
- ii) Reflections.

SECTION - II

- Q7)** a) List various chip packages. Also explain with proper example the function of heat sink. [8]
- b) Write short note on SMD assemblies. [6]
- c) Compare co-axial cable with shielded twisted pair cable. [4]

OR

- Q8)** a) Write short notes on : [8]
- i) Wave soldering.
- ii) Reliability issues in ICs.
- b) Write short note on 'Virtual Instrument'. [6]
- c) State the various features of 'Logic Analyzer'. [4]

Q9) a) In context of digital storage oscilloscope (DSO), explain the significance of the following specifications. [8]

- i) Memory depth.
- ii) Sampling Rate.
- iii) Type of Sampling.
- iv) Bandwidth.

b) Write short note on 'Monte-Carlo Analysis'. [8]

OR

Q10) a) With the help of schematic arrangement explain in detail the type of diagnostic instrument and its features used to comply set up and hold time requirements in memory interfacing. [8]

b) Explain the factors that determine the choice between developing software for a data logger system in : [8]

- i) Assembly language and
- ii) High-level language.

Q11) a) Explain different vibration test that should be carried out on an industrial product. Indicate different parameters/settings associated with these tests. [8]

b) Write short notes on : [8]

- i) In-circuit Emulator.
- ii) Modular Programming.

OR

Q12) a) Compare conducted EMI with Radiated EMI. [8]

b) List various PCB documents. Explain one in brief with suitable example. [8]

* * *

Total No. of Questions : 12]

SEAT No. :

P1235

[Total No. of Pages : 2

[4164]-124
B.E. (E & TC)
VLSI DESIGN
(2003 Pattern) (Sem. - I)

Time :3 Hours]

[Max. Marks :100

Instructions to the candidates:

- 1) *Answer three questions from Section I and three questions from Section II.*
- 2) *Answers to the two sections should be written in separate books.*
- 3) *Neat diagrams must be drawn wherever necessary.*
- 4) *Figures to the right indicate full marks.*

SECTION - I

- Q1)** a) Explain VLSI design flow with reference to any EDA tool. [9]
b) Compare function and procedure in detail. [9]

OR

- Q2)** a) Write VHDL code for one byte bidirectional bus. Also write test bench for it. [9]
b) Explain in detail all modelling used in VHDL. [9]

- Q3)** a) Draw state diagram for 1010 sequence detector and also write VHDL code for it. [8]
b) Draw and explain the block diagram of moore and mealy machines and also comment on speed and hardware. [8]

OR

- Q4)** a) Draw the state diagram of LIFT CONTROLLER. And also write VHDL code for it. [8]
b) Write short note on STA and DTA. [8]

- Q5)** a) Write the features and specifications of CPLD & FPGA in details. [8]
b) Draw the architecture of any CPLD device, and explore function block, macrocell, IOB in detail. [8]

OR

P.T.O.

- Q6)** a) What do you mean by •jed, •edif, •µcf, •vhd, •xnf? Draw the diagram of logic cell of FPGA. [8]
b) Draw and explain the FPGA architecture in detail. [8]

SECTION - II

- Q7)** a) What is clock skew? What are the methods to minimize? Classify the clock skew? [9]
b) What are the challenges in routing? Explain global routing in detail. [9]

OR

- Q8)** a) What is a need of clock distribution. Explain in detail a technique of clock distribution. [9]
b) What are the techniques of EMI immune chip design. How to achieve EMC? [9]

- Q9)** a) Design CMOS logic of $F = ABC + DE + F$. [8]
b) Explain body effect in details. [8]

OR

- Q10)** a) Design CMOS logic for two input EX-OR gate. [8]
b) Design 2:1 MUX. Using transmission gate. [8]

- Q11)** a) What are the stuck faults? Explain any one of the type with the help of example. [8]
b) Draw the architecture of TAP controller and explain in detail. [8]

OR

- Q12)** a) What is necessity of boundary scan. List JTAG pins. [8]
b) What is BIST. With the help of block diagram explain BIST in details. [8]

Total No. of Questions : 12]

SEAT No. :

P1236

[Total No. of Pages : 2

[4164]-125
B.E. (E & TC)
EMBEDDED SYSTEMS DESIGN
(2003 Pattern) (Elective - I) (Sem. - I)

Time :3 Hours]

[Max. Marks :100

Instructions to the candidates:

- 1) *Answer three questions from Section I and three questions from Section II.*
- 2) *Answers to the two sections should be written in separate books.*
- 3) *Neat diagrams must be drawn wherever necessary.*
- 4) *Your answers will be valued as a whole.*
- 5) *Use of logarithmic tables slide rule, Mollier charts, electronic pocket calculator and steam tables is allowed.*
- 6) *Assume suitable data, if necessary.*

SECTION - I

- Q1)** a) Explain with example how design metrics compete with each other. Suggest the methods to trade off these design metrics. [10]
b) Compare CAN & MODBUS protocol. [8]

OR

- Q2)** a) Explain recent trends and challenges in embedded system design. [8]
b) Write note on : [10]
i) Bluetooth.
ii) IEEE 802.11

- Q3)** a) What are the guidelines to select processor for embedded system. [8]
b) What is interrupt latency? Explain steps involved in context switch. [8]

OR

- Q4)** a) Explain memory selection criterions for embedded system. [8]
b) Explain different software architecture for embedded system. [8]
- Q5)** a) What are different scheduling algorithms? Explain any two in short. [8]
b) What is task? Explain task state transitions in detail. [8]

P.T.O.

OR

- Q6)** a) How RTOS is different than general purpose operating system. [8]
b) What is IDE? Explain toolchain in code development. [8]

SECTION - II

- Q7)** a) Differentiate between preemptive and non-preemptive scheduling. [6]
b) Explain shared data problem with an example. [6]
c) Explain deadly embrace condition with semaphores. [6]

OR

- Q8)** a) Compare message mailbox and message queue. Explain preferred use of these message communication primitives. [10]
b) Compare memory management in RTOS and general purpose OS. [8]

- Q9)** Explain following approaches in RTOS: [16]
a) Monolithic.
b) Microkernel.
c) Decoupled.

OR

- Q10)** a) Explain software development life cycle. [8]
b) Explain various features of MCOS-II operating system. [8]
- Q11)** Explain hardware and software component involved in digital camera. [16]

OR

- Q12)** a) Explain adaptive cruise control system in automobile. [8]
b) Explain smart card reader as an embedded system in brief. [8]

Total No. of Questions : 12]

SEAT No. :

P1237

[Total No. of Pages : 3

[4164]-126
B.E. (E & TC)
ADVANCED POWER ELECTRONICS
(Elective - I) (2003 Pattern) (Sem. - I)

Time :3 Hours]

[Max. Marks :100

Instructions to the candidates:

- 1) *Answer Q1 or Q2, Q3 or Q4, Q5 or Q6, questions from Section - I and Q7 or Q8, Q9 or Q10, Q11 or Q12 questions from Section - II.*
- 2) *Answers to the two sections should be written in separate books.*
- 3) *Neat diagrams must be drawn wherever necessary.*
- 4) *Figures to the right indicate full marks.*
- 5) *Use of logarithmic tables slide rule, Mollier charts, electronic pocket calculator and steam tables is allowed.*
- 6) *Assume suitable data, if necessary.*

SECTION - I

- Q1)** a) Draw the circuit diagram of three phase fully controlled converter operating with highly inductive load and explain operation with following waveforms for $\alpha = 120^\circ$. **[12]**
- i) Load voltage.
 - ii) Load current.
 - iii) Supply current (any one phase)
 - iv) Current through SCR (any one)
- b) For a string of 3 series connected SCRs, draw static and dynamic equalizing circuits and explain how these circuits ensure equal voltage sharing under all possible operating conditions. **[6]**

OR

- Q2)** a) Why are dual converters important? With the help of neat circuit diagram and relevant waveforms, explain the operation of three-phase circulating mode dual converter. **[10]**
- b) Explain the effect of source inductance on the performance of a single phase full-converter indicating clearly the conduction of various thyristors during one cycle. **[8]**

P.T.O.

- Q3)** a) With the help of neat circuit diagram and relevant waveforms, explain the operation of 3- ϕ voltage source 180° mode bridge inverter feeding a balanced star connected resistive load. [10]
- b) For the above circuit derive expression for the following : [6]
- i) R.M.S phase o/p voltage
 - ii) R.M.S line o/p voltage
 - iii) Device utilization factor

OR

- Q4)** a) With the help of circuit diagram explain the circuit of Boost inverter circuit. [6]
- b) Briefly explain any one technique for output voltage control and harmonic reduction in inverters. [6]
- c) Compare between V.S.I. and C.S.I. [4]

- Q5)** Explain the concept of power factor. On which parameters does the power factor depend? Enlist various power factor improvement techniques for line commutated converters. Explain any one method of power factor improvement in details compare it with other techniques. [16]

OR

- Q6)** a) With the help of neat circuit diagram and associated waveforms, explain the operation of class E resonant inverters. [8]
- b) How will you measure [8]
- i) Sinusoidal voltage and current.
 - ii) Nonsinusoidal voltage and current.

SECTION - II

- Q7)** a) With the help of neat circuit diagram and relevant waveforms explain the operation of bipolar voltage chopper drive for P.M. and hybrid stepper motor. [10]
- b) Explain “Soft start” in D.C. motor drives. [4]
- c) Explain “Field failure and under voltage protection for D.C. motor. [4]

OR

- Q8)** a) Draw and explain the power circuit of semiconverters feeding a separately excited d.c. motor. Explain with typical voltage and current waveforms, the operation in continuous armature current modes. [8]

- b) A 210V, 1200 rpm, 10A separately excited motor is controlled by a 1-phase fully controlled converter with an a.c. source voltage of 230V, 50Hz. Assume that sufficient inductance is present in the armature circuit to make the motor current continuous and ripple free for any torque greater than 25 percent of rated torque $R_a = 1.5 \Omega$. [10]
- What should be the value of the firing angle to get the rated torque at 800 rpm?
 - Compute the firing angle for the rated braking torque at - 1200 rpm.
 - Calculate the motor-speed at the rated torque and $\alpha = 165^\circ$ for the regenerative braking in second quadrant?

- Q9)** a) With the help of circuit diagram and the motor torque-speed characteristic, explain stator voltage speed control of induction motors. [8]
- b) With the help of neat circuit diagram and appropriate torque-speed curves, explain the slip power recovery scheme for speed control of induction motors in both sub-synchronous and super synchronous speed regions. [8]

OR

- Q10)** a) Draw and explain the operation of three-phase brushless d.c. motor drive. Also explain the related waveforms. [10]
- b) Explain briefly the following methods of braking a d.c. motor. [6]
- Regenerative braking.
 - Dynamic braking.
 - Plugging.

- Q11)** a) What is power quality? Why it is required? Explain different types of power line disturbances. [8]
- b) Explain contribution of supply and load in power quality. [8]

OR

- Q12)** a) What is Energy audit? Explain types of Energy audit. [8]
- b) Define the term sag? Explain different sources of sags and interruptions. [8]

* * *

Total No. of Questions : 12]

SEAT No. :

P1238

[Total No. of Pages : 2

[4164]-128
B.E. (E & TC)
ARTIFICIAL NEURAL NETWORKS
(2003 Pattern) (Elective - I) (Sem. - I)

Time :3 Hours]

[Max. Marks :100

Instructions to the candidates:

- 1) *Answer 3 questions from Section I and 3 questions from Section II.*
- 2) *Answers to the two sections should be written in separate books.*
- 3) *Neat diagrams must be drawn wherever necessary.*
- 4) *Use of logarithmic tables slide rule, Mollier charts, electronic pocket calculator and steam tables is allowed.*
- 5) *Assume suitable data, if necessary.*

SECTION - I

- Q1)** a) Explain biological neuron model. Also give the comparison of the same with computer neural networks. **[12]**
- b) What is the distinction between learning law and learning equation. **[6]**

OR

- Q2)** a) Compare : **[9]**
- i) McCulloch Pitts Model.
 - ii) Perceptron Model.
 - iii) Adaline Model.
- b) What are the different types of competitive learning. **[4]**
- c) What is the difference between stability & convergence. **[5]**

- Q3)** a) Explain adaline algorithm with the architecture **[8]**
- b) Derive perceptron law. Explain the gradient descend rule of perceptron. **[8]**

OR

- Q4)** a) Explain Back propagation algorithm with the architecture. **[10]**
- b) Explain MR-III algorithm **[6]**

P.T.O.

- Q5)** a) Explain Boltzmann algorithm and architecture. [8]
b) Explain the energy analysis in a 3 input hopfield network. [8]

OR

- Q6)** a) Explain the working of hopfield N/W with the help of energy landscape diagrams. [8]
b) Explain simulated annealing. How it can be used to escape local minima. [8]

SECTION - II

- Q7)** a) Explain the algorithm and architecture of ART-I. What is the effect of vigilance parameter in ART-I network. [12]
b) Explain the use of maxnet. [4]

OR

- Q8)** a) Explain SOM with architecture. [8]
b) Explain simple competitive network with algorithm. [8]

- Q9)** a) Explain the architecture and application of Neocognitron. [8]
b) Explain TAM & BAM. [8]

OR

- Q10)** a) Explain stability plasticity dilemma & a way to solve it. [8]
b) Explain Heteroassociative memories. [8]

- Q11)** a) Explain application of neural network in control system field. [9]
b) Explain application of neural network in Image Processing. [9]

OR

- Q12)** a) Explain Travelling Salesman problem & the way to solve it. [9]
b) Explain how neural network can be used in speech related application. [9]

* * *

Total No. of Questions : 12]

SEAT No. :

P1239

[Total No. of Pages : 2

[4164]-130
B.E. (E & TC)
ELECTRONIC MEASUREMENT SYSTEMS
(2003 Pattern) (Sem. - II)

Time :3 Hours]

[Max. Marks :100

Instructions to the candidates:

- 1) *Answers to the two sections should be written in separate books.*
- 2) *Neat diagrams must be drawn wherever necessary.*
- 3) *Figures to the right indicate full marks.*

SECTION - I

- Q1)** a) Sketch a ckt to show how a standard voltmeter may be used to calibrate a dc voltmeter. Explain the calibrating procedure and discuss the use of calibration chart. **[10]**
- b) Explain the procedure of phase and Magnitude Measurement at high frequencies. **[8]**

OR

- Q2)** a) Explain with the neat diagram Autoranging in DMM. What do you mean by Autozeroing in DMM. **[8]**
- b) Explain the operation of : **[10]**
- i) Digital LCR meter.
 - ii) True RMS responding voltmeter.
- Q3)** a) Draw and explain the block diagram of Digital Storage oscilloscope. Also explain the modes of operation of digital storage oscilloscope. **[10]**
- b) Explain 'Gating Error' in frequency measurement using frequency counter. **[6]**

OR

- Q4)** a) Explain fundamental suppression harmonic distortion analyzer. **[10]**
- b) Write a brief note on TCXO. **[6]**
- Q5)** a) Write brief note on : **[8]**
- i) Regression Analysis.
 - ii) Calibration Methodologies.

P.T.O.

- b) Explain the operation of : [8]
i) FFT analyser.
ii) Protocol analyser.

OR

- Q6)** a) Write in brief about various CRO probes & their applications. [8]
b) State the principle of dual trace CRO. Explain with block diagram. [8]

SECTION - II

- Q7)** a) State the specifications & applications of Logic Analyzer & Spectrum Analyzer. [8]
b) Why network analyzer is used? Explain scalar Network Analysis. [10]

OR

- Q8)** a) Explain virtual measurements & its applications in TDM, FDM. [4]
b) What is the difference between harmonic distortion analyser & wave analyser. [4]
c) Explain ATE setup with block diagram for measurement of various parameter of audio amplifier. [10]

- Q9)** a) What is IEEE 488 bus system? Which are the management lines in IEEE 488 bus? [10]
b) What are the basic tasks of an automatic test systems? [6]

OR

- Q10)** a) Write short notes on : [8]
i) Virtual instruments.
ii) Lab view.
b) Write short note on PCI/PCI express interface. [8]

- Q11)** a) With the help of block schematics explain any two virtual instrumentation classes. [8]
b) Write a note on any one virtual instrumentation software. [8]

OR

- Q12)** a) Draw & explain the block diagram of SINAD sensitivity test set-up. What is 'phase jitter'? [10]
b) Describe two methods for measuring sensitivity of the receiver. [6]

* * *

Total No. of Questions : 12]

SEAT No. :

P1240

[Total No. of Pages : 2

[4164]-131
B.E. (E & TC)
TELECOMMUNICATION NETWORK & MANAGEMENT
(2003 Pattern) (Sem. - II)

Time :3 Hours]

[Max. Marks :100

Instructions to the candidates:

- 1) Answers to the two sections should be written in separate books.*
- 2) Neat diagrams must be drawn wherever necessary.*
- 3) Figures to the right indicate full marks.*
- 4) Use of logarithmic tables, slide rule, Mollier charts, electronic pocket calculator and steam tables is allowed.*
- 5) Assume suitable data, if necessary.*

SECTION - I

- Q1)** a) State & explain the major components of network in detail. [10]
b) What are the different types of networks? Explain any two of them in brief with architecture. [8]

OR

- Q2)** a) State & explain the difference between packet switching & circuit switching with block schematic. [8]
b) State various Network design tools & explain any one of them in brief.[10]
- Q3)** a) What are the interfaces used in ISDN? With the block schematic explain the reference points used in ISDN. [8]
b) Draw and explain the architecture of Frame Relay and explain various layers used in it. [8]

OR

- Q4)** a) With an appropriate example explain the operation of Virtual Path switch & Virtual Path Connection switch used in ATM. [8]
b) Draw a simple SONET network and explain various SONET devices used in it. [8]
- Q5)** a) With the help of neat diagram explain Hybrid Fiber Co-ax network and different bands used in it. [8]
b) What are the types and typical uses of Leased Lines? Explain. [8]

P.T.O.

OR

- Q6)** a) What is meant by WLL? Explain the advantages of WLL over wired technology and specify the standards used for WLL. [8]
- b) Write short note on following : [8]
- i) ADSL modem and DSLAM.
 - ii) HDSL.

SECTION - II

- Q7)** a) Give the classification of Routing Algorithms? Explain each one in detail. [10]
- b) What is Flooding? What are its applications? Explain. [8]

OR

- Q8)** a) With a neat diagram explain the various steps involved in Link State Routing algorithm. Also with an example explain the information contained in Routing Tables for each router in a network. [10]
- b) Write short notes on following : [8]
- i) Hierarchical routing.
 - ii) Flow based routing.

- Q9)** a) Define QoS of a telecom network. Also explain different Flow characteristics assigned to flow. [8]
- b) Explain the different types of delays occurred in a switching networks. [8]

OR

- Q10)** a) Write short notes on following with reference to telecom network : [8]
- i) Crosstalk interference.
 - ii) Reliability.
 - iii) Survivability.
- b) What is Jitter? How can it be controlled? Explain. [8]

- Q11)** a) Explain in detail the telecom network operations and maintenance. [10]
- b) What are the needs for Fault management? Draw and explain the architecture of fault management system. [6]

OR

- Q12)** a) Draw and explain the architecture of security management. [10]
- b) What are different strengths and weaknesses of SNMP? Explain. [6]

* * *

Total No. of Questions : 12]

SEAT No. :

P1241

[Total No. of Pages : 3

[4164]-132
B.E. (E & TC)
OPTICAL AND MICROWAVE COMMUNICATION
(2003 Pattern) (Sem. - II)

Time :3 Hours]

[Max. Marks :100

Instructions to the candidates:

- 1) *In Section I : Attempt Q.1 or Q.2, Q.3 or Q.4, Q.5 or Q.6
In Section II : Attempt Q.7 or Q.8, Q.9 or Q.10, Q.11 or Q.12*
- 2) *Answers to the two sections should be written in separate books.*
- 3) *Neat diagrams must be drawn wherever necessary.*
- 4) *Figures to the right indicate full marks.*
- 5) *Use of logarithmic tables, slide rule, Mollier charts, electronic pocket calculator and steam tables is allowed.*
- 6) *Assume suitable data, if necessary.*

SECTION - I

- Q1)** a) Explain in detail the structure of edge emitting LED. [6]
- b) A graded index fiber has a core with a parabolic refractive index profile which has a diameter of 50 micrometres. The fiber has a numerical aperture of 0.2. Estimate the total number of guided modes propagating in the fiber when it is operating at a wavelength of 1 micrometre. [6]
- c) With the help of neat diagram explain the construction and working of PIN photodiode. [6]

OR

- Q2)** a) What is LASER? Mention population inversion condition. Compare LASER and LED. [6]
- b) With the help of neat diagram explain the construction and working of Avalanche Photodiode. [6]
- c) Compare : [6]
- i) Plastic optical fibers and glass fibers.
 - ii) Multimode Step Index Fibers and Multimode Graded Index Fibers
- .

P.T.O.

- Q3)** a) What is meant by Absorption and Rayleigh Scattering Losses? Explain with neat diagrams. [6]
b) What is OTDR? Draw the block schematic and explain its working. [6]
c) Explain macrobending and microbending effects in optical fibers. [4]

OR

- Q4)** a) Define Fiber Splicing? Explain different types of splicing. [6]
b) A multimode graded index fiber exhibits total pulse broadening of 0.1 microsecond over a distance of 15 km. Estimate: [6]
i) The maximum possible bandwidth on the link assuming no intersymbol interference.
ii) The pulse dispersion per unit length.
iii) The bandwidth-length product for the fiber.
c) What is dispersion? Explain material dispersion. [4]

- Q5)** a) Explain the concept of wavelength division multiplexing and state the key system features of wavelength division multiplexing. [8]
b) What are the three classes of optical amplifiers and explain their applications. [8]

OR

- Q6)** a) What are the key system requirements that needed in analyzing a point-to-point link? Explain the point-to-point link design with reference to the choice of components and their associated characteristics. [8]
b) A four port multimode fiber FBT coupler has 60 microwatts optical power launched into port 1. The measured output power at port 2, 3 and 4 are 0.004, 26.0 and 27.5 microwatts respectively. Determine the excess loss, the insertion losses between the input and output ports, the crosstalk and the split ratio for the device. [8]

SECTION - II

- Q7)** a) With the help of diagram, explain the operation of two-hole directional coupler. State its uses. [8]
b) Explain working of microwave isolator and give its applications. [6]
c) Design a rectangular waveguide to propagate 10 GHz signal under dominant mode. [4]

OR

- Q8)** a) Discuss the power losses and power transmitted in rectangular waveguide. [8]
- b) Determine the cut off wavelength for the dominant mode in a rectangular waveguide of breadth 10 cms. For a 2.5 GHz signal propagated in this waveguide in the dominant mode; calculate the guide wavelength, the group velocity and phase velocity. [6]
- c) Differentiate between TE and TM modes in rectangular waveguides. [4]

- Q9)** a) Explain the frequency limitation of the conventional tubes. How can it be overcome with microwave tubes. [8]
- b) Explain the principle of working of a Reflex Klystron. Where it is used. [8]

OR

- Q10)** a) What do you mean by crossfield device? Explain the phase focussing effect in magnetron. [8]
- b) Compare TWT and Klystron. [4]
- c) A helical TWT has diameter of 2 mm with 50 turns per cm. Calculate: [4]
- i) Axial Phase velocity.
- ii) The anode voltage at which the TWT can be operated for useful gain.

- Q11)** a) List the different operating modes of Gunn diode. Explain LSA mode and give limitation of this mode. [8]
- b) Describe how Tunnel diode can be used as an amplifier and oscillator. [8]

OR

- Q12)** Describe the salient features and applications of the following microwave devices : [16]
- a) Varactor diode.
- b) PIN diode.
- c) Microstrip line.
- d) Microwave transistor.

* * *

Total No. of Questions : 12]

SEAT No. :

P1242

[Total No. of Pages : 3

[4164]-133
B.E. (E & TC)
ADVANCED COMMUNICATION SYSTEMS
(2003 Pattern) (Elective - II) (Sem. - II)

Time :3 Hours]

[Max. Marks :100

Instructions to the candidates:

- 1) *Answer any three questions from each section.*
- 2) *Answers to the two sections should be written in separate books.*
- 3) *Neat diagrams must be drawn wherever necessary.*
- 4) *Figures to the right indicate full marks.*
- 5) *Use of logarithmic tables, slide rule, Mollier charts, electronic pocket calculator and steam tables is allowed.*
- 6) *Assume suitable data, if necessary.*

SECTION - I

- Q1)** a) Explain the three and four port fiber coupler. **[8]**
- b) A 4 port multimode fiber coupler has $60\mu\text{w}$ optical power launched into port 1. The measured output powers at ports 2, 3 and 4 are 0.004, 26.0, and $27.5\mu\text{w}$ respectively. Determine the excess loss, the insertion losses between the input and output ports, the crosstalk and the split ratio for the device. **[8]**

OR

- Q2)** a) Explain the wavelength division multiplexing couplers. **[8]**
- b) Explain the operational principles of WDM along with its key features. **[8]**
- Q3)** a) Discuss the basic structure of an synchronous transport signal (STS)-1 SONET frame along with its transmission rates. **[8]**
- b) Explain the SONET/SDH ring architecture. **[8]**

OR

- Q4)** a) Draw and explain the optical CDMA network. **[8]**
- b) Explain the Broadcast and select WDM networks. **[8]**

P.T.O.

Q5) a) What are Kepler's three laws of planetary motion? Give the mathematical formulation of Kepler's third law of planetary motion. What do the terms perigee and apogee mean when used to describe the orbit of a satellite orbiting the earth? [9]

b) Explain the Attitude and Orbit Control System (AOCS) of a satellite. [9]

OR

Q6) a) Draw and explain the double conversion transponder used in satellites. [9]

b) Explain the steps involved in placing satellites into Geostationary orbit. [9]

SECTION - II

Q7) a) Explain the baseband transmission of digital data in satellite system. [9]

b) Explain the Band-pass transmission of digital data in digital satellite communication system. [9]

OR

Q8) a) Explain the transmission of QPSK signals through a bandlimited channel in satellite system. [9]

b) Explain FM used in satellite communication with respect to its waveform equation, bandwidth S/N ratio & pre-emphasis & de-emphasis. [9]

Q9) a) A satellite at a distance of 40,000 km from a point on the earth's surface radiates a power of 10W from an antenna with a gain of 17dB in the direction of the observer. Find the flux density at the receiving point and the power received by an antenna at this point with an effective area of 10m². [8]

b) Draw the block diagram of double conversion earth station receiver and explain its functioning. [8]

OR

Q10) a) Explain the satellite communication link design procedure. [8]

b) An earth station antenna has a diameter of 30m, has an overall efficiency of 68% and is used to receive a signal at 4150 MHz. At this frequency, the system noise temperature is 79K when the antenna points at the satellite at an elevation angle of 28°. What is the earth station G/T ratio under these conditions? If heavy rain causes the sky temperature to increase so that the system noise temperature rises to 88K, what is the new G/T value. [8]

- Q11)** a) Explain the Demand Access Multiple Access (DAMA) system used in satellite communication. [8]
- b) Explain the Time Division Multiple Access (TDMA) technique used in satellite communication systems. [8]

OR

- Q12)** a) Draw and explain the VSAT system. [8]
- b) Explain the channel coding techniques used in VSAT system. [8]

* * *

Total No. of Questions : 12]

SEAT No. :

P1243

[Total No. of Pages : 3

[4164]-134
B.E. (E & TC)
DIGITAL IMAGE PROCESSING
(2003 Pattern) (Elective - II) (Sem. - II)

Time :3 Hours]

[Max. Marks :100

Instructions to the candidates:

- 1) *Answer three questions from each section.*
- 2) *Answers to the two sections should be written in separate answer books.*
- 3) *Figures to the right indicate full marks.*
- 4) *Neat diagrams must be drawn wherever necessary.*
- 5) *Assume suitable data, if required.*

SECTION - I

- Q1)** a) What is connectivity between pixels? Explain 4 connectivity, 8 connectivity and mixed connectivity. **[8]**
- b) Explain the following : **[8]**
- i) Simultaneous contrast.
 - ii) MTF of human visual system.

OR

- Q2)** a) Discuss YIQ and HSI color model. **[8]**
- b) Briefly explain the following : **[8]**
- i) Webber's ratio.
 - ii) Scotopic threshold and glare limit.

OR

- Q3)** a) What are the three basic types of functions used for image enhancement. Explain in brief. **[8]**
- b) Explain image enhancement using histogram processing. **[8]**

OR

- Q4)** a) What are the steps in frequency domain filtering? Explain. **[8]**
- b) Explain Homomorphic filter. **[8]**

P.T.O.

- Q5)** a) Explain the following properties of the 2D Fourier transform : [9]
- i) Translation.
 - ii) Rotation.
 - iii) Scaling.
 - iv) Convolution.
- b) Write the equation for 2D Walsh transform. Obtain the Walsh basis images for $N = 4$. [9]

OR

- Q6)** a) What is Discrete Cosine transform? Explain the properties in detail. [9]
- b) Explain multi-resolution decomposition using Wavelet Transform. [9]

SECTION - II

- Q7)** a) What is data redundancy? Explain the various data redundancies identified in Image data. [8]
- b) Image matrix of 4 bits/pixel image is given as follows [8]
- | | | | |
|----|----|----|---|
| 15 | 15 | 10 | 8 |
| 15 | 10 | 8 | 8 |
| 15 | 10 | 8 | 8 |
| 10 | 8 | 8 | 8 |
- Find i) Huffman code for gray levels in the image.
 ii) Compression ratio.
 iii) Average length of the code words.

OR

- Q8)** a) Briefly explain following coding algorithm : [8]
- i) Bit plane coding.
 - ii) Predictive coding.
- b) Explain with block diagram JPEG compression. [8]
- Q9)** a) Explain image segmentation by point detection, line detection and edge detection. [8]
- b) Discuss image segmentation using split and merge technique. [8]

OR

- Q10)** a) Explain binary erosion operation. How it can be used for boundary extraction. [8]
- b) What is chain code? How it can be used for boundary representation? [8]

- Q11)** a) Discuss use of image processing in character recognition. [9]
b) Explain remote sensing using satellite images. [9]

OR

- Q12)** a) Draw and explain model of Image degradation and restoration process. [9]
b) Explain image restoration by inverse filtering. [9]

* * *

Total No. of Questions : 12]

SEAT No. :

P1244

[Total No. of Pages : 3

[4164]-136
B.E. (E & TC)
AUDIO & VIDEO ENGINEERING
(2003 Pattern) (Elective - II) (Sem. - II)

Time :3 Hours]

[Max. Marks :100

Instructions to the candidates:

- 1) *Answer any three questions from each section.*
- 2) *Answers to the two sections should be written in separate books.*
- 3) *Neat diagrams must be drawn wherever necessary.*
- 4) *Figures to the right indicate full marks.*
- 5) *Use of electronic pocket calculator is allowed.*
- 6) *Assume suitable data, if necessary.*

SECTION - I

- Q1)** a) Explain the following terms with neat sketches. **[10]**
- i) Chromaticity diagram.
 - ii) Frequency interleaving.
- b) Compare different display technologies used for color TV. **[8]**

OR

- Q2)** a) Define the following terms. **[10]**
- i) Hue.
 - ii) Saturation.
 - iii) Luminance.
 - iv) Aspect ratio.
 - v) CFF.
- b) Explain the working of precision-in-line picture tube using neat diagram. State its merits & demerits. **[8]**
- Q3)** a) Draw a neat block diagram of high level modulated TV transmitter & explain function of each block. **[8]**
- b) Explain the importance of pattern generator in TV receiver alignments. **[4]**
- c) How weighted U and V signals are produced in case of PAL transmission. **[4]**

OR

P.T.O.

- Q4)** a) Draw a neat block diagram of color TV receiver & explain function of each block. [8]
b) Explain the use of wobuloscope in color TV fault finding. [4]
c) Compare PAL with SECAM color TV system. [4]

- Q5)** a) With the help of block diagram explain the operation of basic MAC encoder. [8]
b) Explain the MPEG-2 video compression format. [4]
c) Compare digital TV system with analog TV system. [4]

OR

- Q6)** a) What is the difference between component coding & composite coding? State the important parameters for digitized video signal. [8]
b) Compare the performance of interlace & progressive scanning used in DTV systems. [4]
c) State the objectives of JPEG standard. [4]

SECTION - II

- Q7)** a) Discuss a live TV coverage plan for a cricket match. Draw the schematic diagram to show the camera placement at different locations & other equipment set up for live broadcast. [10]
b) With the help of block diagram explain CCTV system. State its applications. [8]

OR

- Q8)** a) With the help of neat block diagram explain the direct broadcasting satellite (DBS) technique for TV broadcasting. [10]
b) State the features of HDTV. Using neat block diagram explain the operation of HDTV encoder. [8]

- Q9)** a) Explain the principle of magnetic recording & reproduction technique. State the relationship between gap-width, tape speed & frequency of audio signal. [8]
b) Discuss the MPEG audio compression formats/standards indicating the different specifications used. [8]

OR

Q10) a) What is the difference betⁿ CD & DVD player? Draw a neat block diagram of DVD player & explain function of each block. [8]

b) Explain in detail 5.1 sound system indicating the merits & demerits of the same. [8]

Q11) a) Define the following terms : [8]

- i) Reverberation.
- ii) Sound Reduction Index.
- iii) Echo.
- iv) Acoustic feedback.

b) Explain satellite radio receiver system with suitable block diagram. [8]

OR

Q12) a) State the requirements of a good auditorium for pleasant listening. Discuss the salient features of accoustical design for an auditorium. [8]

b) Write short notes on : [8]

- i) Graphic equalizer.
- ii) Cordless microphone.

* * *

Total No. of Questions : 12]

SEAT No. :

P1245

[Total No. of Pages : 2

[4164]-137

B.E. (E & TC)

SYSTEM PROGRAMMING AND OPERATING SYSTEMS

(2003 Pattern) (Elective - II) (Sem. - II)

Time :3 Hours]

[Max. Marks :100

Instructions to the candidates:

- 1) *Answer 3 questions from Section - I and 3 questions from Section - II.*
- 2) *Answers to the two sections should be written in separate answer books.*
- 3) *Neat diagrams must be drawn wherever necessary.*
- 4) *Figures to the right indicate full marks.*
- 5) *Use of logarithmic tables slide rule, Mollier charts, electronic pocket calculator and steam tables is allowed.*
- 6) *Assume suitable data, if necessary.*

SECTION - I

- Q1)** a) Draw a block diagram of structure of a compiler. Explain lexical and syntax analysis phase of compiler. [8]
- b) Explain the language processor development tools. [8]

OR

- Q2)** a) Explain the different components of system software. [8]
- b) Explain the following terms in detail : [8]
- i) Interpreter.
 - ii) Linker.
 - iii) System Software.
 - iv) Translator.

- Q3)** a) Explain data structures used for PASS-I Macroprocessor. [8]
- b) Describe Phase-I and Phase-II of assemblers design. [10]

OR

- Q4)** a) Explain the forward referencing with suitable example. [8]
- b) Define Macro and explain Macro expansion with suitable example of nested Macro. [10]

P.T.O.

- Q5)** a) What is Dynamic loader? Explain it in detail. [8]
b) Name the various types of loaders and enlist the function of each in brief. [8]

OR

- Q6)** a) What are the databases required during Pass-I and Pass-II of direct linking loader? Explain them. [8]
b) Write note on : [8]
i) Relocation loader.
ii) MS-DOS linker.

SECTION - II

- Q7)** a) Describe process synchronization in detail. Explain producer-consumer problem. [10]
b) Explain in brief different operating system. [8]

OR

- Q8)** a) What is scheduling? Differentiate between preemptive and non-preemptive scheduling. Explain one method of scheduling for each. [10]
b) What is deadlocks? Explain Banker's algorithm with suitable example. [8]

- Q9)** a) Explain virtual memory using segmentation. [8]
b) Compare contiguous and non-contiguous memory allocation. [8]

OR

- Q10)** a) Describe paging technique. Explain the steps of page fault handling in virtual memory system. [8]
b) Write note on : [8]
i) File Sharing.
ii) Network File System (N.F.S.)

- Q11)** a) Explain direct I/O with polling and interrupt driven I/O. [8]
b) Explain the single buffer and double buffer in case of I/O buffering. [8]

OR

- Q12)** Write short notes on : [16]
a) Device Drivers.
b) Serial and parallel port programming.
c) USB.
d) Physical IOCS

* * *

Total No. of Questions : 12]

SEAT No. :

P1246

[Total No. of Pages : 3

[4164]-143

B.E. (Instrumentation & Control)

DIGITAL CONTROL

(2003 Pattern) (Sem. - I)

Time : 3 Hours]

[Max. Marks : 100

Instructions to the candidates:

- 1) *Answer any three questions from each section.*
- 2) *Answer to the two sections should be written in separate books.*
- 3) *Neat diagrams must be drawn wherever necessary.*
- 4) *Assume suitable data, if necessary.*
- 5) *Use of electronic pocket calculator is allowed.*

SECTION - I

Q1) The discrete time system is described by the transfer function, [16]

$$G(z) = \frac{Y(z)}{R(z)} = \frac{0.05z}{z - 0.95}$$

Find the response $y(k)$ to the input,

- a) $r(k) = \delta(k)$
- b) $r(k) = \mu(k)$
- c) $r(k) = R_0 \cos(\Omega k)$

OR

Q2) a) Find the stability of the system using Jury's test if the system is having characteristic equation as, [6]

$$F(z) = z^4 - 1.2z^3 + 0.2z^2 + 0.05z - 0.001 = 0$$

- b) Derive the model of a zero order hold from the first principles. [6]
- c) Give the advantages of digital control over analog one. [4]

Q3) For the system shown in the figure design a dead beat controller. [16]

Assume $T = 1$ sec.

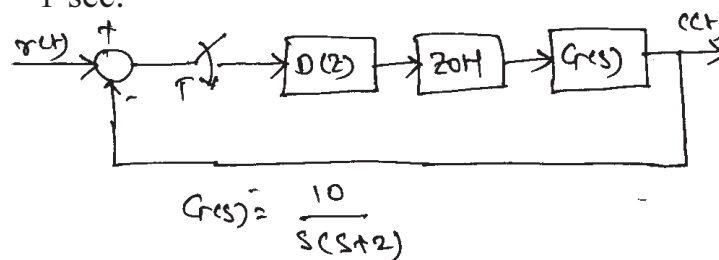

P.T.O.

OR

Q4) a) Explain the concept of ringing of poles? How ringing can be eliminated? [10]

b) What are the salient features of the dead beat controller? [6]

Q5) a) A LTI system with the state equation. [8]

$$\begin{bmatrix} x_1(k+1) \\ x_2(k+1) \end{bmatrix} = \begin{bmatrix} 0 & 1 \\ 0 & -2 \end{bmatrix} \begin{bmatrix} x_1(k) \\ x_2(k) \end{bmatrix}.$$

Compute the solution of the homogenous equation assuming the initial

state vector $x(0) = \begin{bmatrix} 1 \\ 0 \end{bmatrix}$.

b) Diagonalise the plant matrix for the system having the state equation as,

$$x(k+1) = \begin{bmatrix} 0 & 1 & 0 \\ 0 & 0 & 1 \\ 0 & 0.4 & 0.3 \end{bmatrix} x(k) + \begin{bmatrix} 0 \\ 0 \\ 1 \end{bmatrix} u(k). \text{ Find the diagonal matrix also.}$$

[10]

OR

Q6) a) For a system with the state equation $x(k+1) = Gx(k) + Hu(k)$ where

$$G = \begin{bmatrix} 0 & 0.81 \\ 1 & 0 \end{bmatrix} \text{ and } H = \begin{bmatrix} 0 \\ 1 \end{bmatrix}. \text{ Find the stability of the system using Liapunov's}$$

stability criteria. Find the Liapunov function also. [6]

b) Find the state model of the system with the pulse transfer function given below, [6]

$$\frac{Y(z)}{R(z)} = \frac{z^{-1} + 2z^{-2}}{1 + 0.7z^{-1} + 0.12z^{-2}}.$$

c) Derive the state transition matrix for the state model derived in part (b) [6]

SECTION - II

Q7) a) Define state controllability, state observability and output controllability. [6]

b) Find the state controllability, state observability and output controllability for the given system. [10]

$$x(k+1) = \begin{bmatrix} 0 & 1 \\ -25 & -6 \end{bmatrix} x(k) + \begin{bmatrix} 0 \\ 1 \end{bmatrix} u(k)$$

$$y(k) = [3 \quad 3]x(k).$$

OR

- Q8)** a) Write short notes on : **[8]**
i) State Observers.
ii) State Variable feedback gain matrix.
b) Find the state feedback gain matrix for the system so that it exhibits a deadbeat response, **[8]**

$$x(k+1) = Gx(k) + Hu(k)$$

$$G = \begin{bmatrix} 0 & 1 \\ -0.24 & -1 \end{bmatrix}, H = \begin{bmatrix} 1 \\ 1 \end{bmatrix}.$$

- Q9)** Write short notes on : **[18]**
a) Self Tuning Regulator.
b) Hybrid Control.
c) Adaptive Control.

OR

- Q10)** a) Explain in detail how the dead time is compensated using Smith's Predictor algorithm. **[9]**
b) Write short notes on : **[9]**
i) Model Predictive Control.
ii) Internal Model Controller.

- Q11)** Why system identification is necessary. List out various parametric and non-parametric methods for the system identification. Explain any one model with the help of equations. **[16]**

OR

- Q12)** For a system with the state equation as, **[16]**
 $x(k+1) = Gx(k) + Hu(k)$, determine the control sequence to minimize the given performance index. Also find J_{\min}

$$J = \frac{1}{2}[x(0)]^2 + \frac{1}{2}\sum[x^2(k) + u^2(k)]$$

$$G = 0.3679.$$

$$H = 0.6321.$$

$$x(0) = 1.$$

* * *

Total No. of Questions : 12]

SEAT No. :

P1247

[Total No. of Pages : 3

[4164]-144

B.E. (Instrumentation & Control)
BIOMEDICAL INSTRUMENTATION
(2003 Pattern) (Elective - I) (Sem. - I)

Time :3 Hours]

[Max. Marks :100

Instructions to the candidates:

- 1) *Answer three questions from each section.*
- 2) *Answer to the two sections should be written in separate books.*
- 3) *Neat diagrams must be drawn wherever necessary.*
- 4) *Figures to right indicate full marks.*
- 5) *Assume suitable data, if necessary.*

SECTION - I

- Q1)** a) Define Electrode offset potential? How effect of electrode offset potential is overcome. Explain the various properties that bio-electrode should possess. [8]
- b) Define bio electrode. Enlist various types of basic bio electrodes used for bioelectric potential measurements, explicate the necessity of microelectrode, Micropipette electrode. [8]

OR

- Q2)** a) What is a half cell potential? Draw and explain electrical equivalent circuit of electrode jelly and Tissue. [8]
- b) Define and discuss the term "Biosensors". [6]
- c) What are the important of use of Electrolytic Jelly at the skin - electrode interface? [2]

- Q3)** a) Enlighten in detail the pumping action of the heart and the genesis of ECG waveform. [8]
- b) Discuss the various ECG leads configuration in detail. [8]

OR

- Q4)** a) List out various bioelectric preamplifiers. Explain chopper amplifier in detail. [10]
- b) Draw and explain Heart Rate meter. [6]

P.T.O.

- Q5)** a) Discuss Doppler shift Ultrasonic blood flow measurement along with neat diagram. [8]
b) Explain electromagnetic blood flow measurement with neat diagram. [8]
c) Enlist the microphones used in phonocardiograph. [2]

OR

- Q6)** a) Enlist two important techniques used in sphygmomanometer BP measurement. Explain the same method of BP measurement along with its advantages and disadvantages. [10]
b) List out various methods used for cardiac output measurement. Explain indicator dilution method with dilution curve. [8]

SECTION - II

- Q7)** a) What is EEG? Explain the 10-20 Electrode placements. [10]
b) Explain the various types of EEG Electrodes. [6]

OR

- Q8)** a) Explain the functions of various lobes of cerebrum. Define cranium Nerves and enlist them. [8]
b) Draw and explicate the brain stem along with function of each part of it. [6]
c) Define Evoked response? [2]

- Q9)** a) Define a "Hearing threshold". Explain the Bekesy audiometer with the help of suitable block diagram. [10]
b) What are three main sections of Human auditory system? Explain the function performed by each section in human hearing phenomenon. [6]

OR

- Q10)** a) Explain the principles involved in intraocular pressure measurement of indentation and applanation tonometer. [10]
b) Clarify various errors in vision and their method of correction. [4]
c) Suggest suitable devices that are used to recover the percentage losses in EAR or EYE, if some residual capacity has been remain with these organs. [2]

- Q11) a) Define the followings: [10]**
Gross shock,
Let go Current,
Lung Compliance
Micro current shock,
Hold on current.
- b) Explain the various methods of accident prevention in medical equipments. [8]

OR

- Q12) a) What is Spiro gram? Draw & explain Wedge Spiro meter for respiratory measurement. [10]**
- b) Draw and explain infrared gas analyzer. [8]

* * *

Total No. of Questions : 12]

SEAT No. :

P1248

[Total No. of Pages : 2

[4164]-145

B.E. (Instrumentation & Control)

INSTRUMENTATION FOR ENVIRONMENTAL ENGINEERING

(2003 Pattern) (Elective - I) (Sem. - I)

Time :3 Hours]

[Max. Marks :100

Instructions to the candidates:

- 1) *Answer three questions from each section.*
- 2) *Answer to the two sections should be written in separate books.*
- 3) *Neat diagrams must be drawn wherever necessary.*
- 4) *Figures to right indicate full marks.*
- 5) *Assume suitable data, if necessary.*

SECTION - I

Q1) a) Explain Biochemical cycles in detail. [8]

b) Discuss on various sensors used for measurement of pollutions. [8]

OR

Q2) a) Discuss on online measurements and continuous monitoring environment. [8]

b) Explain importance of pollution control. [8]

Q3) a) Discuss on Salt Spray Environmental Testing. [8]

b) What is Threshold Limiting Value (TLV). Explain biological sampling and their measurements. [8]

OR

Q4) a) Explain Free-Fall Testing and Bump Testing. [8]

b) Write short note on ISO 14001 standards. [8]

Q5) a) Explain analysis of aerosols and monitoring of gaseous pollutants. [10]

b) Explain instrumentation setup for pollution analysis. [8]

OR

Q6) a) How to monitor suspended particulate matters and trace metal pollutants. [8]

b) Discuss on HVAC Controls. [10]

P.T.O.

SECTION - II

- Q7)** a) Explain different biological investigations waste water. [8]
b) Describe sequence of operations of sludge treatment. [8]

OR

- Q8)** a) Enlist Primary, Secondary and tertiary treatments of domestic effluents. [8]
b) Explain different physical examinations of water pollution analysis. [8]

- Q9)** Enlist different sensors used for noise measurements. Explain a typical noise control system. [16]

OR

- Q10)** a) What are effects of radiation pollution on nonliving things. [8]
b) Suggest different controls of radiation pollutants. [8]

- Q11)** a) Explain different pesticide analyses. [6]
b) Write short notes on : [12]
i) Analysis of micronutrients.
ii) Polorographic analysis.

OR

- Q12)** a) Explain a typical instrumentation setup of soil pollution reduction. [10]
b) Explain Environmental Impact Assessment. [8]

Total No. of Questions : 12]

SEAT No. :

P1249

[Total No. of Pages : 3

[4164]-146

B.E. (Instrumentation & Control)

LASER APPLICATIONS IN INSTRUMENTATION

(2003 Pattern) (Elective - I) (Sem. - I)

Time :3 Hours]

[Max. Marks :100

Instructions to the candidates:

- 1) *Answer three questions from section I and section II.*
- 2) *Answers to the two sections should be written in separate books.*
- 3) *Neat diagrams must be drawn wherever necessary.*
- 4) *Use of electronic pocket calculator is allowed.*
- 5) *Assume suitable data, if necessary.*

SECTION - I

- Q1)** a) Explain in detail the process of emission and absorption of radiation. [8]
b) Explain the importance of Einstein's equations in emissions of radiation. [8]

OR

- Q2)** a) State the different processes due to which the small gain coefficients of laser get affected. [8]
b) Write short notes on : [8]
i) Laser modes.
ii) Q switching.

- Q3)** a) What are different laser system features which are applicable to most commercial and industrial lasers? Explain each in short. [9]
b) Estimate the efficiency of a GaAs laser operating well above threshold. The refractive index of material is 3.5 and laser cavity length is 0.3 mm. the loss coefficient is 800 per metre length and the internal quantum efficiency is 0.7. [4]
c) What are the steps that should be followed in a safe laser laboratory operation? [5]

OR

P.T.O.

- Q4)** a) Explain the construction and working of GaAs homojunction semiconductor diode laser. [8]
b) How the laser products are classified for safety standards? [4]
c) Calculate the threshold pumping power of a Nd: Glass laser for critical population inversion of $9 \times 10^{21}/\text{m}^3$ and spontaneous life time of $250\mu\text{s}$. The upper level is at an energy of 1.3eV . [6]

- Q5)** a) Describe how Fabry-Perot interferometer is used with small coherent length source for displacement measurements. [8]
b) What is Speckle Pattern? Describe subjective and objective speckles. [8]

OR

- Q6)** a) Describe the dynamic tracking of speckle pattern for displacement measurements. [8]
b) What are the properties of speckle pattern? Describe each in short. [8]

SECTION - II

- Q7)** a) Explain the principle of operation of Laser velocimeter. [8]
b) What are the two options for the electronic processing of the Doppler signal? Compare it. [8]

OR

- Q8)** a) Explain the frequency domain processing of Doppler signal in detail. [8]
b) What are the performance parameters of operation of laser velocimeter? Discuss. [8]

- Q9)** a) What is Sagnac effect? Show how is the phase shift is proportional to the angular velocity. [8]
b) What are the components required for all fiber FOG configuration? Explain each in short. [8]

OR

- Q10)** a) Show that the frequency of the sagnac signal in RLG is proportional to the angular velocity of rotation. [8]
b) Explain in detail the closed loop configuration of Fiber Optic Gyroscope. [8]

- Q11)** a) Write a short note on Holographic Interferometer. [9]
b) What are different emulsions used to record the holograms? Mention the characteristics of it. [9]

OR

- Q12)** a) A thin strip of the hologram undergoing stress parallel to the x -axis is illuminated by a He-Ne laser. The fringes are localized in a plane having slope of 1.4 per unit length in x -direction and the fringe spacing is found to be 1 mm. Hence find the strain. [8]
b) List out the applications of holographic interferometer that you know. Explain any one in detail. [10]

* * *

Total No. of Questions : 12]

SEAT No. :

P1250

[Total No. of Pages : 4

[4164]-147

B.E. (Instrumentation & Control)
ADVANCED CONTROL SYSTEM
(2003 Pattern) (Elective - I) (Sem. - I)

Time :3 Hours]

[Max. Marks :100

Instructions to the candidates:

- 1) *Answer 3 questions from Section I and 3 questions from Section II.*
- 2) *Answers to the two sections should be written in separate books.*
- 3) *Neat diagrams must be drawn wherever necessary.*
- 4) *Figures to the right indicate full marks.*
- 5) *Your answers will be valued as a whole.*
- 6) *Use of logarithmic tables slide rule, Mollier charts, electronic pocket calculator and steam tables is allowed.*
- 7) *Assume suitable data, if necessary.*

SECTION - I

- Q1)** a) What are the different characteristics of Nonlinear system? [6]
b) Find the Describing function for the Nonlinear system having characteristic as shown in figure No.1 [12]

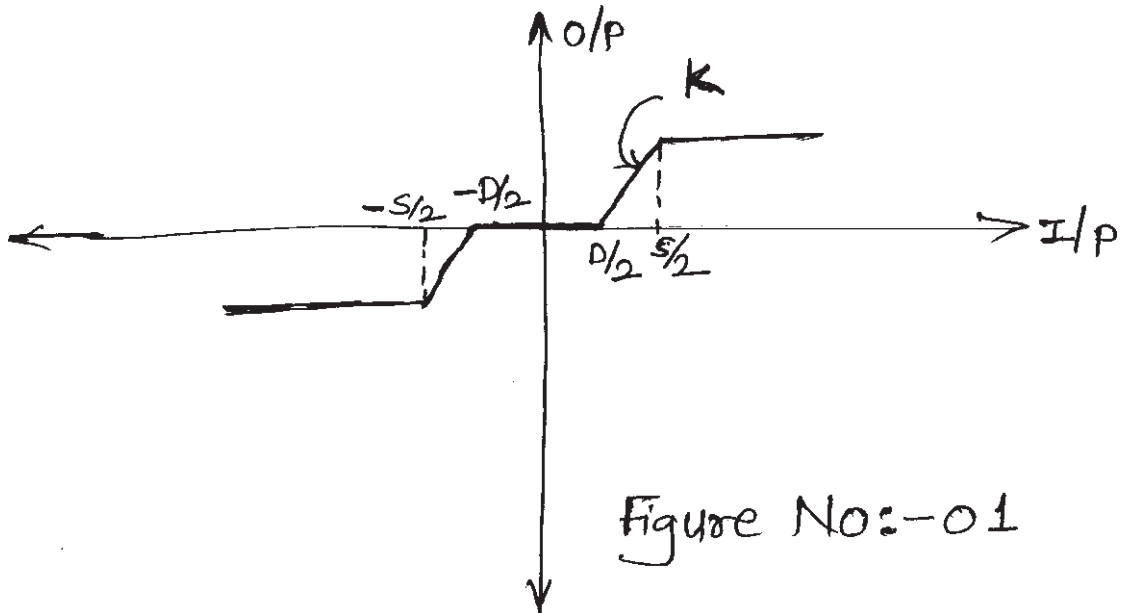

OR

P.T.O.

- Q2)** a) Compare characteristics of Linear & Nonlinear system. [6]
 b) Find the frequency and Amplitude of Limit Cycle(s) for the system as shown in figure No.2 [12]

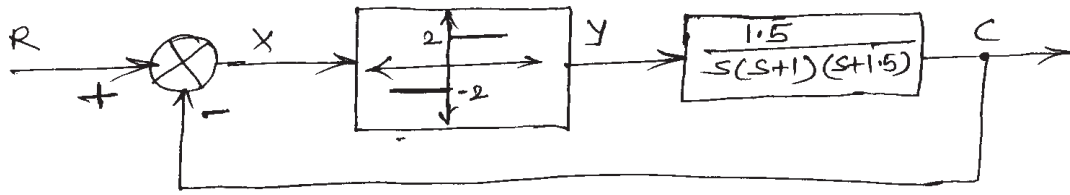

Figure No:- 02

- Q3)** An amplifier as shown in Figure No.3 drives a Two phase servomotor. The transfer function of the motor is $G(s) = \frac{Ke^{-0.1s}}{s(0.1s+1)}$. Investigate the stability of the system for $K = 0.1$. What is the largest value of 'K' for no limit cycles to exist? [16]

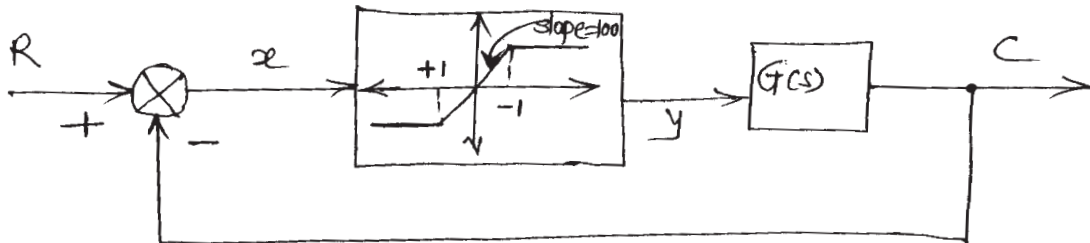

Figure No:- 3

OR

- Q4)** Consider the system as shown in figure No.4. Find the amplitude and frequency of limit cycles. Also comment on the nature of limit cycle(s) and stability of system? [16]

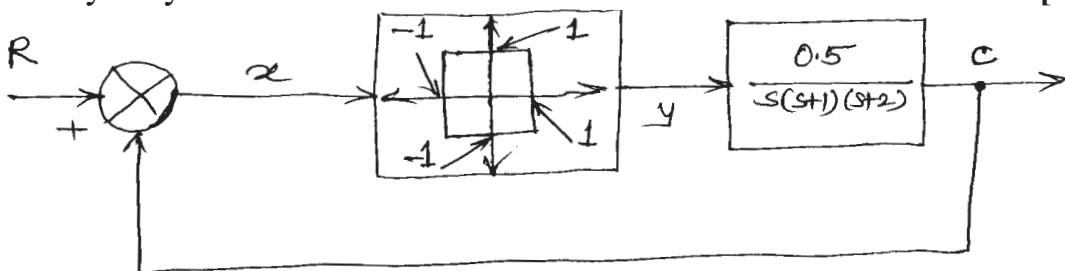

Figure No:- 4

- Q5)** a) What are the different components of Model reference adaptive systems? Explain each in short. [8]
 b) Explain Lyapunov approach for stability analysis of continuous nonlinear time system [8]

OR

- Q6)** a) Explain MIT Rule for Adaptive system. [6]
 b) Consider the Dynamic of Mass-Spring-damper system given by [10]

$$M \frac{d^2 y}{dt^2} + B \frac{dy}{dt} + Ky = u$$

where $M = B = K = 2$

$y =$ Output and $u =$ Input

Design Model Reference Adaptive Control (MRAC) system to follow the response of reference model given by

$$\frac{d^2 y_m}{dt^2} + 15.14 \frac{dy_m}{dt} + y_m = r$$

Select $r = 1$.

SECTION - II

- Q7)** a) Write short note on Indirect Self Tuning Regulator. [6]
 b) In Self Tuning Regulator (STR) following Input Output data has been obtained from real plant. [12]

Time (t)	Input data [$u(t)$]	Output data [$y(t)$]
1	2.0	0.0
2	1.0	4.0
3	2.0	-2.0
4	1.5	4.0
5	1.0	2.0

Use any regression method to fit a model with the structure $y(t) + ay(t-1) = bu(t-1) + e(t)$ where $e(t)$ is error signal.

OR

- Q8)** a) Write short note on : [12]
 i) Linear Quadratic Self Tuning Regulator.
 ii) Continuous time self tuners.
 b) With the help of neat diagram explain different elements of self tuning regulators. [6]
- Q9)** Explain the following industrial adaptive controllers with reference to parameter estimation, control design, prior information and industrial experiences. [16]
 a) EXACT: The Foxboro Adaptive Controller.
 b) DPR 900.

OR

Q10) a) Enlist the considerations of Robust Control System. [8]

b) Explain Feed Control of Distillation column using adaptive control Technique [8]

Q11) a) State equations are [8]

$$\begin{bmatrix} \dot{x}_1 \\ \dot{x}_2 \end{bmatrix} = \begin{bmatrix} -2 & -4 \\ 1 & -4 \end{bmatrix} \begin{bmatrix} x_1 \\ x_2 \end{bmatrix} + \begin{bmatrix} 0 \\ 2 \end{bmatrix} [4]$$

$y = [1 \ 0] \begin{bmatrix} x_1 \\ x_2 \end{bmatrix}$ determined feedback gain matrix for a system & desired pole locations at $-50, -50$.

b) Obtain control law that minimizes the performance Index [8]

$$J = \int_0^{\infty} (x_1^2 + u^2) dt \text{ for the system.}$$

$$\begin{bmatrix} \frac{dx_1}{dt} \\ \frac{dx_2}{dt} \end{bmatrix} = \begin{bmatrix} 0 & 0.1 \\ 0 & 0.1 \end{bmatrix} \begin{bmatrix} x_1 \\ x_2 \end{bmatrix} + \begin{bmatrix} 0 \\ 1 \end{bmatrix} u$$

using reduced matrix Ricatti equation.

OR

Q12) Consider the plant [16]

$$\begin{bmatrix} \frac{dx_1}{dt} \\ \frac{dx_2}{dt} \end{bmatrix} = \begin{bmatrix} 1 & 0 \\ -1 & 0.2 \end{bmatrix} \begin{bmatrix} x_1 \\ x_2 \end{bmatrix} + \begin{bmatrix} 1 \\ 0 \end{bmatrix} u$$

- Is the given system stable?
- Is the given system controllable?
- Select the values for matrices Q and R with the constraint that they are positive definite and design a controller for the plant so as to minimize

$$J = \frac{1}{2} \int_0^{\infty} (x^T Q x + u^T R u) dt$$

Check that the resulting overall system is stable.

* * *

Total No. of Questions : 12]

SEAT No. :

P1251

[Total No. of Pages : 2

[4164]-148

B.E. (Instrumentation & Control)

BUILDING AUTOMATION - I

(2003 Pattern) (Elective - I) (Sem. - I)

Time :3 Hours]

[Max. Marks :100

Instructions to the candidates:

- 1) *Answer to the two sections should be written in separate books.*
- 2) *Neat diagrams must be drawn wherever necessary.*
- 3) *Figures to the right indicate full marks.*
- 4) *Assume suitable data, if necessary.*
- 5) *All questions are compulsory.*

SECTION - I

- Q1)** a) What is Building Automation? Discuss its importance. [8]
b) Draw the block diagram of FAS and explain its working? [10]

OR

- Q2)** a) List various Fire detectors. Explain any one with suitable diagram. [10]
b) Describe intelligent fire alarm system. [8]
- Q3)** a) What are the guidelines for notification devices installation? [8]
b) Discuss various heat detectors with suitable application. [8]

OR

- Q4)** a) Explain dry pipe sprinkler system with suitable application. [8]
b) Discuss power supply requirement and battery calculations of FAS. [8]
- Q5)** a) What do you mean by zoning? Explain importance of zoning. [8]
b) Differentiate between addressable and conventional FAS. [8]

OR

- Q6)** a) List various notification appliances. State specifications of any one. [8]
b) Explain 2-wire & 4-wire smoke detector. [8]

P.T.O.

SECTION - II

- Q7)** a) Explain various components of access control systems. [8]
b) Define FAR & FRR in biometrics. List various biometrics used in Access Control System. Explain any one application of Biometrics. [10]

OR

- Q8)** a) Draw and explain block diagram of security system. [10]
b) Explain working of card reader. [8]

- Q9)** a) Explain automatic special sequential switching devices used in video processing devices. [8]
b) Describe image capture, store and transmission phenomenon in camera. [8]

OR

- Q10)** a) List types of cameras and their applications. [8]
b) Explain various image compression formats in CCTV system. [8]

- Q11)** a) Explain perimeter intrusion? State and explain importance of PIDS. [8]
b) Explain architecture of PIDS. [8]

OR

- Q12)** a) Explain PIDS for airport. [8]
b) Explain technologies used for perimeter intrusion system. [8]

Total No. of Questions : 12]

SEAT No. :

P1252

[Total No. of Pages : 3

[4164]-150

B.E. (Instrumentation & Control)
COMPUTER TECHNIQUES AND APPLICATIONS
(2003 Pattern) (Sem. - II)

Time :3 Hours]

[Max. Marks :100

Instructions to the candidates:

- 1) *Answer any three questions from each section.*
- 2) *Answers to the two sections should be written in separate books.*
- 3) *Neat diagrams must be drawn wherever necessary.*
- 4) *Figures to the right indicate full marks.*
- 5) *Use of logarithmic tables slide rule, Mollier charts, electronic pocket calculator and steam tables is allowed.*
- 6) *Assume suitable data, if necessary.*

SECTION - I

- Q1)** a) List and explain the five states through which a process may go during its execution. **[10]**
- b) Explain the different types of Operating Systems (any four) **[8]**

OR

- Q2)** a) Four processes (P1, P2, P3, P4) arrive at time 0, 2, 4, 5 with their CPU bursts of 7, 4, 1 and 4 respectively. For each of the following CPU scheduling algorithms, draw the Gantt chart and determine the average turn around time and average waiting time, showing all the calculations in detail. **[12]**
- i) First Come First Serve (FCFS)
 - ii) Shortest Job First (SJF) (non preemptive)
 - iii) Shortest Job First (SJF) (preemptive)
 - iv) Round Robin (RR) with a time quantum of 4 CPU bursts.
- b) With neat diagrams explain the following Disk scheduling algorithms. **[6]**
- i) SCAN.
 - ii) C-SCAN.
 - iii) C-LOOK.

P.T.O.

- Q3)** a) With neat diagrams, explain any two file allocation methods. [8]
 b) With the help of neat diagram, explain the concept of thrashing. [8]

OR

- Q4)** Write short notes on : [16]
 a) Demand Paging.
 b) Page Table structures.

- Q5)** a) Write a note on Systolic Arrays on the basis of following points:
 i) Functional block diagram. [4]
 ii) Working. [4]
 b) Design a Huffman code for a source that puts out symbols a1, a2, a3, a4 and a5 with their respective probabilities of occurrence as 0.2, 0.4, 0.2, 0.1 and 0.1 [8]

OR

- Q6)** a) The following figure is the precedence graph of Jobs J1 to J8. The number next to the name of each job is its execution time. The priorities are J1, J2, J3 J8, J1 being the highest priority job. All jobs are released at t = 0. Jobs are scheduled and executed on two processors, P1 and P2. All the jobs are preemptable .

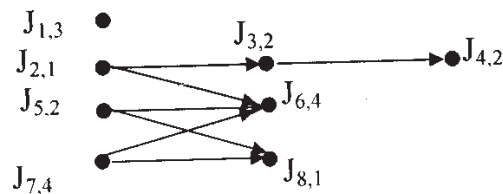

Show the schedule of jobs on P1 and P2 generated by the following priority algorithms :

- i) Preemptive. [4]
 ii) Non preemptive . [4]
 b) Compare the following with respect to parallel computers:
 i) Loosely Coupled and Tightly coupled systems. [4]
 ii) UMA and NUMA parallel computers. [4]

SECTION - II

- Q7)** a) Explain the Transmission Control Protocol/Internet Protocol and explain the tasks carried out at different layers. [8]
 b) Discuss the features and applications of Industrial Ethernet. [8]

OR

- Q8)** a) Explain LAN and LAN topologies. [8]
b) Write short note on IEEE 802.3 [8]

- Q9)** a) Discuss the technical details of IEEE 488. [8]
b) Discuss the architectural overview of ARM 922. [8]

OR

- Q10)** a) List and explain the basic operating modes of ARM processors. [8]
b) Discuss the technical details of IEEE 1394. [8]

- Q11)** Write short notes : [18]
a) Unit testing.
b) Integration testing.
c) Validation testing.

OR

- Q12)** a) Explain the five levels of SEI Capability Maturity Model. [10]
b) Explain in brief the Software Development Life Cycle. [8]

* * *

Total No. of Questions : 12]

SEAT No. :

P1253

[Total No. of Pages : 3

[4164]-151

B.E. (Instrumentation & Control)
INDUSTRIAL AUTOMATION
(2003 Pattern) (Sem. - II)

Time :3 Hours]

[Max. Marks :100

Instructions to the candidates:

- 1) *Answer three questions from Section - I and three questions from Section - II.*
- 2) *Answers to the two sections should be written in separate books.*
- 3) *Neat diagrams must be drawn wherever necessary.*
- 4) *Figures to the right indicate full marks.*
- 5) *Use of logarithmic tables slide rule, Mollier charts, electronic pocket calculator and steam tables is allowed.*
- 6) *Assume suitable data, if necessary.*

SECTION - I

- Q1)** a) Compare PLC, SCADA and DCS. [8]
b) Explain the various types of production system and its required automation system. [8]

OR

- Q2)** a) Explain the various types of production system and its required automation system. [8]
b) Explain the role of PLC in the SCADA system. [8]
- Q3)** a) With an example explain how PID control is implemented using PLC system. [8]
b) Explain the IEC 1131-3 standard. [8]

OR

- Q4)** a) With an example explain SFC Programming. [8]
b) Explain the difference between Master-Slave and Server-Client Communication. [8]

P.T.O.

- Q5)** a) With an example explain the multidrop Networking in HART Protocol. [8]
 b) With respect to OSI model compare HART and Foundation Fieldbus protocols. [10]

OR

- Q6)** a) With respect to OSI model compare HART and Foundation Fieldbus protocols. [10]
 b) Write short note on (any two) : [8]
 i) Device Net.
 ii) Control Net.
 iii) OPC.

SECTION - II

- Q7)** a) Figure 1 shows a cascade control loop, where LC is level controller and FC is Flow controller. Assume that both controllers are of PID controller. IN to LC is given by level transmitter and IN to FC is given by flow transmitter. Set point to LC is provided through operator interface (Faceplate). Write a program using FBD for a DCS system [Assume any make.]. Explain the configuration of each block. [12]
 b) List and explain any two the logical function blocks in the DCS system. [6]

OR

- Q8)** a) Figure 1 shows a cascade control loop, where LC is level controller and FC is Flow controller. Assume that both controllers are of PID controller. IN to LC is given by level transmitter and IN to FC is given by flow transmitter. Set point to LC is provided through operator interface (Faceplate). Write a program using FBD for a DCS system [Assume any make.]. Explain the configuration of each block. [12]

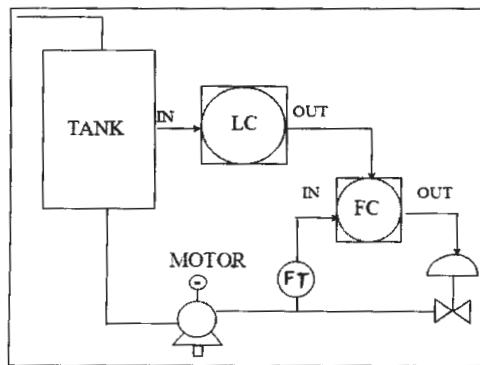

Figure 1: Cascade Control Loop

- b) List and explain any two advance control function blocks in the DCS system. [6]

- Q9)** a) Explain the different types of displays in a DCS system. [8]
b) Write a specifications of DCS system. [8]

OR

- Q10)** a) Why alarm management system is needed? and How a DCS system implements alarm management. [8]
b) What do u mean by user access management? Why it is necessary in DCS system. [8]

- Q11)** With the help of block diagram explain what are the different stages involved in developing the automation for continuous process. [16]

OR

- Q12)** What is meant by safety system? What are the different safety layers? How it is implemented for any industrial application? [16]

* * *

Total No. of Questions : 12]

SEAT No. :

P1254

[Total No. of Pages : 3

[4164]-154

B.E. (Instrumentation & Control)
FIBER OPTIC INSTRUMENTATION
(2003 Pattern) (Elective - II) (Sem. - II)

Time : 3 Hours]

[Max. Marks : 100

Instructions to the candidates:

- 1) *Answer 3 questions from Section I and 3 questions from Section II.*
- 2) *Answers to the two sections should be written in separate answer books.*
- 3) *Neat diagrams must be drawn wherever necessary.*
- 4) *Figures to the right indicate full marks.*
- 5) *Use of logarithmic tables slide rule, Mollier charts, electronic pocket calculator and steam tables is allowed.*

SECTION - I

- Q1)** a) Explain what is meant by a graded index optical fiber, giving an expression for the possible refractive index profile? Using simple ray theory concepts, discuss the transmission of light through the fiber. Indicate the major advantage of this type of fiber with regard to multimode propagation. **[10]**
- b) Briefly indicate with the aid of suitable diagrams the difference between meridional and skew ray paths in step index fibers. **[6]**

OR

- Q2)** a) An optical fiber has a numerical aperture of 0.20 and a cladding refractive index of 1.59. Determine: **[8]**
- i) The acceptance angle for the fiber in water which has a refractive index of 1.33;
 - ii) The critical angle at the core-cladding interface.
- b) Describe with the aid of simple ray diagram : **[8]**
- i) Multimode step index fiber.
 - ii) Single-mode step index fiber.

Compare the advantages and disadvantages of these two types of fiber for use as an optical channel.

P.T.O.

- Q3)** a) Discuss absorption losses in optical fibers, comparing and contrasting the intrinsic and extrinsic absorption mechanisms. [9]
- b) Briefly describe linear scattering losses in optical fibers with regard to : [8]
- i) Rayleigh scattering.
- ii) Mie scattering.

OR

- Q4)** a) Compare stimulated Brillouin and stimulated Raman scattering in optical fibers. [8]
- b) Explain Micro bending and Macro bending in optical fiber. Also explain what the critical bending radius for an optical fiber means. [9]
- Q5)** a) Briefly describe the processes by which light can be emitted from an atom. Discuss the requirements for population inversion in order that stimulated emission may dominate over spontaneous emission. Illustrate your answer with an energy level diagram of a common nonsemiconductor laser. [9]
- b) Compare P-I-N diode with avalanche photodiode. [8]

OR

- Q6)** a) Describe what is meant by the fusion splicing of optical fibers. Discuss the advantages and drawbacks of this jointing technique. [8]
- b) Discuss the principles of operation of the two major categories of demountable optical fiber connectors. Describe in detail a common technique for achieving a butt jointed fiber connector. [9]

SECTION - II

- Q7)** What are the advantages of Intensity Modulated Optical Sensors (IMOS)? Describe following techniques of sensing which is based on intensity modulation. Also enlist different parameters, which can be sensed by using these techniques. [18]
- a) Evanescent field.
- b) Coupling.
- c) Encoding based position sensors.

OR

- Q8)** a) What do you understand by intrinsic and extrinsic Optical Fiber Sensors? With the aid of suitable diagrams describe one Extrinsic Optical Fiber Sensor. How do you calibrate this sensor? [10]
- b) What are the advantages and drawbacks of Optical Fiber Sensors? [8]

- Q9)** a) Explain working of Fiber Bragg Grating. Also explain the manufacturing technique of Fiber Bragg Grating. [8]
b) Explain working of Distributed Optical Fiber stress-strain sensor. [8]

OR

- Q10)** a) What are the advantages and disadvantages of Distributed Optical Fiber Sensing? Explain role of Optical Time Domain Reflectometer (OTDR) in Distributed Optical Fiber Sensing. [8]
b) How different parameters are sensed by using Fiber Bragg Grating. [8]
- Q11)** a) Sketch the major elements of a fiber amplifier and describe the operation of the device. Indicate the benefits of fiber amplifier technology in comparison with that associated with silicon laser amplifiers (SLAs). [10]
b) Write a note on 'Integrated Optics'. [6]

OR

- Q12)** a) Give major reasons which have led to the development of optical amplifiers, outlining the attributes and application areas for these devices. [8]
b) Explain with the aid of suitable diagrams, following integrated optical devices : [8]
i) Beam splitter.
ii) Directional coupler.

* * *

Total No. of Questions : 6]

SEAT No. :

P1255

[Total No. of Pages : 3

[4164]-155

B.E. (Instrumentation & Control)
PROCESS MODELING & OPTIMIZATION
(2003 Pattern) (Elective - II) (Sem. - II)

Time :3 Hours]

[Max. Marks :100

Instructions to the candidates:

- 1) *Answer 3 questions from Section - I and 3 questions from Section - II.*
- 2) *Answers to the two sections should be written in separate books.*
- 3) *Neat diagrams must be drawn wherever necessary.*
- 4) *Figures to the right indicate full marks.*
- 5) *Use of logarithmic tables slide rule, Mollier charts, electronic pocket calculator and steam tables is allowed.*
- 6) *Assume suitable data, if necessary.*

SECTION - I

- Q1)** Find the model of system shown in Fig.1 assuming 'x' is output and 'f' is input. **[18]**

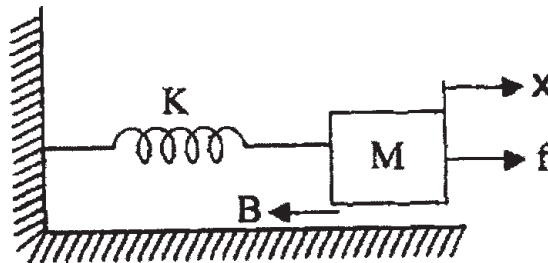

Also obtain the unit step response of the systems assuming all parameters value are unity.

OR

What are the different advantages of mathematical modeling in process industries? Explain principles of formulation of model and types of models.

- Q2)** Explain in short working of distillation column. Explain the important steps involved in modeling of the ideal distillation column. **[16]**

OR

Obtain the model of non isothermal continuous stirred tank reactor.

P.T.O.

Q3) Explain the following in system identification with suitable schematic diagram. **[16]**

- a) Pulse testing.
- b) Sine wave testing.

OR

Write short note on :

- a) ATV identification method.
- b) Off-line and On-line identification.

SECTION - II

Q4) Consider a system **[18]**

$$G(s) = \begin{bmatrix} \frac{0.126e^{-6s}}{60s+1} & \frac{-0.101e^{-12s}}{(48s+1)(45s+1)} \\ \frac{0.094e^{-8s}}{38s+1} & \frac{-0.12e^{-8s}}{35s+1} \end{bmatrix}$$

Find RGA and NI.

OR

Write short notes on :

- a) Resiliency and Morari resiliency index.
- b) Explain interaction and decoupler in multivariable processes.

Q5) Explain the following : **[16]**

- a) Convex functions and continuity of a function.
- b) Gradient of a function and Hessian matrix.

OR

Determine the optimum values of the following functions and state whether they are minimum or maximum.

a) $f(x) = 3x_1^2 - 4x_1x_2 + 2x_2.$

b) $f(x) = \frac{x_1^2}{4} + \frac{2}{x_1x_2} + 4x_2.$

Q6) Write short note on :

a) Scanning and bracketing for optimization. [8]

b) Polynomial approximation methods. [8]

OR

Explain in short the following methods for single variable optimization.

a) Newton.

b) Quasi-Newton.

c) Secant method.

* * *

Total No. of Questions : 12]

SEAT No. :

P1256

[Total No. of Pages : 3

[4164]-156

B.E. (Instrumentation & Control)
BUILDING AUTOMATION - II
(2003 Pattern) (Elective - II) (Sem. - II)

Time :3 Hours]

[Max. Marks :100

Instructions to the candidates:

- 1) *Answers to the two sections should be written in separate books.*
- 2) *Neat diagrams must be drawn wherever necessary.*
- 3) *Figures to the right indicate full marks.*
- 4) *Use of logarithmic tables slide rule, Mollier charts, electronic pocket calculator and steam tables is allowed.*
- 5) *Assume suitable data, if necessary.*

SECTION - I

- Q1)** a) Explain various specifications on Psychometric chart. **[10]**
b) Explain terms : **[8]**
i) Specific Heat
ii) Latent Heat.
iii) Sensible Heating.
iv) Sensible Cooling.

OR

- Q2)** a) Explain different factors affecting to Human comfort. Give classification of Human comfort. **[12]**
b) Explain Absolute Humidity & Relative Humidity. **[6]**
- Q3)** a) Explain various devices of Vapor Compression Cycle. **[8]**
b) Explain Air Handler Unit. **[8]**

OR

- Q4)** a) Explain Steam System. **[8]**
b) Explain Central FAN System. **[8]**

P.T.O.

- Q5)** a) Explain terms: [10]
i) Optimum start.
ii) Night Cycle.
iii) Night purge.
iv) Load Reset.
v) Power demand.

- b) List out different input & output field components of DDC. [6]

OR

- Q6)** a) What are building management functions in DDC. [8]

- b) Explain on-off control & Floating control. [8]

SECTION - II

- Q7)** a) Explain momentary start-stop circuit of MCC. [8]

- b) Explain LON Bus protocol. [8]

OR

- Q8)** a) Explain BACnet Protocol with following points : [10]

- i) Objective.
ii) Elements.
iii) System operation.
iv) Safety & Security.

- b) List various protocol used in HVAC. [6]

- Q9)** a) Draw various ASHARE symbols. [10]

- b) What do you mean Green Building? Explain the goals of Green Building. [8]

OR

- Q10)** a) Explain IBMS system with following points : [10]

- i) Objective
ii) Heart of system.
iii) Features.

- b) What do you mean energy management? Explain types of Energy Measurement Devices. [8]

- Q11)** a) Explain different features of IBMS & list benefits of IBMS. [8]
b) Explain BMS verticals. [8]

OR

- Q12)** a) Describe the IBMS architecture. [10]
b) Explain the role of Energy management in security & HVAC systems.[6]

* * *

Total No. of Questions : 12]

SEAT No. :

P1257

[Total No. of Pages : 2

[4164]-181
B.E. (Chemical)
PROCESS DYNAMICS AND CONTROL
(2003 Pattern) (Sem. - I)

Time :3 Hours]

[Max. Marks :100

Instructions to the candidates:

- 1) *Answers to the two sections should be written in separate books.*
- 2) *Neat diagrams must be drawn wherever necessary.*
- 3) *Figures to the right indicate full marks.*
- 4) *Assume suitable data, if necessary.*

SECTION - I

- Q1)** a) What are incentives for chemical process control? [8]
b) Discuss the design elements for control system. [8]

OR

- Q2)** a) Discuss the types of forcing functions. [8]
b) Focus on the history of process control. [8]

- Q3)** a) Derive the transfer function for response of Mercury thermometer. State the assumptions used. [10]
b) Explain the characteristics of underdamped response in second order system. [8]

OR

- Q4)** a) Derive the transfer function for Interacting Liquid Level system. State all the assumptions. [10]
b) Determine the ultimate value of response for following transfer function when subjected to unit step change in input. [8]

$$GP(s) = \frac{1}{(s+1)^2}$$

- Q5)** A first order process is controlled by P controller. Assuming servo problem and $\tau_p = k_p = 1$ & $G_m(s) = G_f(s) = 1$, determine; [16]
a) Closed loop transfer function.
b) Closed loop time constant & gain.

P.T.O.

- c) Order of response.
- d) Offset.

OR

- Q6)** Write short notes on : **[16]**
- a) On-Off controller.
 - b) Positive v/s Negative feedback system.
 - c) Poles and Zeros.
 - d) Transport Lag.

SECTION - II

- Q7)** a) Define stability and discuss the use of characteristic equation for stability analysis. **[8]**
- b) Discuss the steps to sketch a root-locus diagram with suitable example. **[8]**

OR

- Q8)** a) Sketch the Bode plot for PI controller. **[8]**
- b) Sketch the Nyquist plot for PI controller. **[8]**

- Q9)** Draw a neat diagram and explain the working of : **[18]**
- a) Cascade control system.
 - b) Selective control.

OR

- Q10)** Discuss in detail about the working of following : **[18]**
- a) Ratio control.
 - b) Split Range Control.

- Q11)** Draw an instrumentation diagram and discuss in detail about the functioning of all the elements for plantwide control for plants involving compressors. **[16]**

OR

- Q12)** Write short notes on : **[16]**
- a) Role of Digital computers in control.
 - b) Controller Tuning.
 - c) Z-transform.
 - d) Adaptive control.

Total No. of Questions : 12]

SEAT No. :

P1258

[Total No. of Pages : 3

[4164]-182

B.E. (Chemical Engineering)

CHEMICAL REACTION ENGINEERING - II

(2003 Pattern) (Sem. - I)

Time :3 Hours]

[Max. Marks :100

Instructions to the candidates:

- 1) *Answer three questions from each section.*
- 2) *Answers to the two sections should be written in separate books.*
- 3) *Neat diagrams must be drawn wherever necessary.*
- 4) *Figures to the right indicate full marks.*
- 5) *Use of logarithmic tables, slide rule, Mollier charts, electronic pocket calculator and steam tables is allowed.*
- 6) *Assume suitable data, if necessary.*

SECTION - I

- Q1)** a) What are the various factors responsible for determination of the rate controlling step in fluid-particle reaction. Explain each factor in detail. **[10]**
- b) For fluid particle reactions, derive the expression for time of complete conversion for small particles in stokes regime. **[8]**

OR

- Q2)** Two small samples of solids are introduced into a constant environment oven and kept there for 1/hr under these conditions the 4 mm particles are 58% converted, 2 mm particles are 87.5% converted. Find the rate controlling mechanism for the conversion of solids. Also find the time needed for complete conversion of 1 mm particles in this oven. **[18]**

- Q3)** a) A fluid-fluid reaction of type
 $A \text{ (From Gas)} + bB \text{ (Liquid)} \rightarrow \text{Product (Liquid)}$
takes place in reactor. A reaction is fast with (i) moderate C_B and (ii) High C_B . Derive the rate expression for both cases. **[8]**
- b) Derive the rate expression for slurry reaction kinetics. **[8]**

OR

P.T.O.

- Q4)** The concentration of an undesirable impurity, A in air is to be reduced from 0.1% to 0.02% by reactive liquid which contains a high concentration of reactant B, Find the height of the tower required for counter-current operation. Data Given: The reaction takes place in the liquid and is extremely rapid.

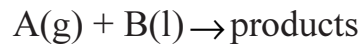

Assume that the diffusivities of A and B in reactive liquid are same, i.e.

$$k_{A1} = k_{B1} = k_1$$

$$k_{Ag} a = 32000 \text{ mol/hr.m}^3 \cdot \text{atm}$$

$$k_{A1} a = 0.1/\text{hr.}$$

$$H_A = 125 \times 10^{-6} \text{ atm.m}^3/\text{mol}$$

$$L \approx L' = 7 \times 10^5 \text{ mol/hr.m}^2$$

$$G \approx G' = 1 \times 10^5 \text{ mol/hr.m}^2$$

$$\pi = 1 \text{ atm}$$

[16]

- Q5)** a) Explain the types of adsorption in solid catalysed reactions. [6]
 b) Low temperature (-195.8°C) nitrogen adsorption data were obtained for an Fe-Al₂O₃ ammonia catalyst. The results for a 50.4 g sample were: [10]

Pressure in mm Hg	8	30	50	102	130	148	233	258	330	442	480	507	550
Volume Absorbed, cm ³ (0°C, 1 atm)	103	116	130	148	159	163	188	198	221	270	294	316	365

OR

- Q6)** a) Explain types of catalyst poisons in detail. [8]
 b) The following data were obtained at 70°C for the equilibrium adsorption of n-hexane on silica gel particles.

Partial pressure of C ₆ H ₁₄ in gas, atm	C ₆ H ₁₄ adsorbed, g mol/(g gel)
0.0020	10.5 × 10 ⁻⁵
0.0040	16.0 × 10 ⁻⁵
0.0080	27.2 × 10 ⁻⁵
0.0113	34.6 × 10 ⁻⁵
0.0156	43.0 × 10 ⁻⁵
0.0206	47.3 × 10 ⁻⁵

Determine the values of constants \bar{C}_m and K_c for Langmuir isotherm by least-square-analysis. [8]

SECTION - II

- Q7)** a) Explain diffusion in porous catalysts with the help of experimental procedure. [8]
b) Explain and derive an expression for effectiveness factor. [8]

OR

- Q8)** a) Write a short note on mass transfer with reaction with the help of effectiveness factor in catalytic reactions. [8]
b) Explain Diffusion in porous catalysts with the help of suitable sketch. [8]

- Q9)** The catalytic reaction $A \rightarrow 4R$ is studied in a plug flow reactor using various amounts of catalyst and 20 liter/hr. of pure A feed at 3.2 atm and 117°C the concentration of A in the effluent stream is recorded for the various runs as follows : [16]

Run	1	2	3	4	5
Catalyst Used, kg	0.020	0.040	0.080	0.120	0.160
$C_{A, out}$, mol/lit	0.074	0.060	0.044	0.035	0.029

- a) Find the rate equation for this reaction using integral method of analysis.
b) Find the rate equation using differential method of analysis.

OR

- Q10)** Write a short note on :

- a) Construction and operation of fixed bed reactor. [8]
b) Recycle Reactor. [8]

- Q11)** Write a short note on :

- a) Heat Effects in a packed bed reactor. [9]
b) Mixed Flow reactor. [9]

OR

- Q12)** a) Explain in detail design of fluidized bed reactor. [10]
b) Explain Michaelis-Menton Kinetics with its model parameters. [8]

Total No. of Questions : 12]

SEAT No. :

P1259

[Total No. of Pages : 2

[4164]-183
B.E. (Chemical)
CHEMICAL PROCESS SYNTHESIS
(2003 Pattern) (Sem. - I)

Time :3 Hours]

[Max. Marks :100

Instructions to the candidates:

- 1) *Answers to the two sections should be written in separate answer books.*
- 2) *Neat diagrams must be drawn wherever necessary.*
- 3) *Figures to the right indicate full marks.*
- 4) *Use of logarithmic tables slide rule, Mollier charts, electronic pocket calculator and steam tables is allowed.*
- 5) *Assume suitable data, if necessary.*

SECTION - I

- Q1)** a) Synthesize a detailed process for acetone production from isopropanol with hydrogen as a byproduct, considering : **[12]**
- i) Formulation of design problem.
 - ii) Hierarchy and approach to process design.
- b) Explain grassroot design. **[4]**

OR

- Q2)** a) Mention different types of reaction systems and discuss any two with suitable example. **[8]**
- b) Discuss Onion model for process design. **[8]**
- Q3)** a) Explain idealized reactor model for ideal batch reactor, mixed and plug flow reactor. **[10]**
- b) Derive the correlation to explain the effect of temperature on selectivity and reactor volume. **[6]**

OR

- Q4)** a) Explain four possible arrangements for fixed bed reactors. **[8]**
- b) Discuss the effect of reactor pressure on the selectivity and reactor volume. **[8]**

P.T.O.

- Q5)** a) Explain the behaviour of mixtures during azeotropic distillation. [10]
b) Explain the concept of degrees of freedom in the design of evaporator. [8]

OR

- Q6)** Write short notes on : [18]
a) Practical reactors.
b) Fluidized bed catalytic reactor.
c) Absorption.

SECTION - II

- Q7)** a) Explain heat integration in sequencing of simple distillation column. [8]
b) Discuss thermal coupling for direct and indirect distillation sequencing. [8]

OR

- Q8)** a) Discuss heuristics used for the sequence selection for simple distillation column. [8]
b) What is optimization of a reducible structure. [8]

- Q9)** a) Explain heat recovery problem with one hot stream and one cold stream with suitable illustrative example. [8]
b) What is simple furnace method. [8]

OR

- Q10)** a) Explain graphically heat recovery pinch. [8]
b) Explain criteria for utility selection. [8]

- Q11)** a) Explain the intensification of hazardous materials. [10]
b) Explain schematically servo reaction system. [8]

OR

- Q12)** Write short notes on : [18]
a) Safety and health considerations.
b) Unconfined vapour cloud explosion.
c) Integration of refrigeration cycle.

Total No. of Questions : 12]

SEAT No. :

P1260

[Total No. of Pages : 2

[4164]-190

B.E. (Chemical)

ADVANCED SEPARATION PROCESSES

(2003 Pattern) (Elective - I) (Sem. - I)

Time :3 Hours]

[Max. Marks :100

Instructions to the candidates:

- 1) Answer 3 questions from Section I and 3 questions from Section II.
- 2) Answers to the two sections should be written in separate books.
- 3) Neat diagrams must be drawn wherever necessary.

SECTION - I

Q1) Define Adsorption and discuss about Temperature Swing Adsorption and Pressure Swing Adsorption with neat sketches. [16]

OR

Q2) a) Explain the basic concept of liquid chromatography process. [4]

b) Give the details of chromatographic column design and filling? [6]

c) Give the application of chromatography. [6]

Q3) a) Find the flux equation in dialysis process. [8]

b) Explain in detail 'Membrane configurations'. [8]

OR

Q4) a) What is the 'Osmotic Pressure'? Explain the mechanism of Reverse osmosis in detail with neat diagram. [8]

b) Explain pervaporation process with schematic diagram. [8]

Q5) Explain in detail 'separation based on reversible chemical complexation'. [18]

OR

Q6) Write short notes : [18]

a) Reactive distillation.

b) Reactive crystallization.

c) Reactive Extraction.

P.T.O.

SECTION - II

- Q7)** a) Explain design and development of flotation equipment. [8]
b) Explain the team formation with collapse and drainage phenomena. [8]

OR

- Q8)** a) Give the flotation application to protein and enzyme separation. [8]
b) Explain the principle and working of Froth Flotation. [8]

- Q9)** a) What is adductive crystallization? Give the classification of adductive crystallization. [12]
b) Explain 'Clathrates' & 'Adducts'. [4]

OR

- Q10)** Explain in detail 'Zone Electrophoresis' and 'Zone refining'. [16]

- Q11)** a) Give the example of 'Ring oven Technology'. [6]
b) What is the Recoil Method? and explain in detail. [12]

OR

- Q12)** Explain the following term : [18]
a) Molecular Sieves and its application.
b) Ultra Centrifugation Process.

Total No. of Questions : 12]

SEAT No. :

P1261

[Total No. of Pages : 2

[4164]-185
B.E. (Chemical Engineering)
ENVIRONMENTAL ENGINEERING
(2003 Pattern) (Elective - I) (Sem. - I)

Time :3 Hours]

[Max. Marks :100

Instructions to the candidates:

- 1) *Answer any three questions from each section.*
- 2) *Answers to the two sections should be written in separate books.*
- 3) *Neat diagrams must be drawn wherever necessary.*
- 4) *Figures to the right indicate full marks.*
- 5) *Use of logarithmic tables slide rule, Mollier charts, electronic pocket calculator and steam tables is allowed.*
- 6) *Assume suitable data, if necessary.*

SECTION - I

- Q1)** a) What are the adverse effects of population growth on environment. Discuss in detail.
b) Discuss the environmental impact of thermal, hydro and nuclear energy. [16]

OR

- Q2)** a) Discuss about clean development mechanism in detail.
b) Write in detail about Kyoto protocol. [16]

- Q3)** a) What are the different particulate emission control techniques.
b) With neat sketch explain working principle and equation of efficiency for
i) Cyclone separator.
ii) ESP. [18]

OR

- Q4)** a) What are the sources and standards for sox pollution.
b) Discuss how to control sox emission. [18]

P.T.O.

Q5) Discuss the operating principle of spray tower & centrifugal scrubber, with neat diagram. [16]

OR

Q6) Discuss with neat figure the operating principle of removal of SO₂ by absorption column. Give the equation involved in it. [16]

SECTION - II

Q7) a) What is least square method? How it is used to calculate BOD constants for wastewater?
b) Compute the reaction constant K and ultimate first stage BOD using least square method for the following results on a sample of untreated wastewater at 20°C.

<i>t</i> (days)	2	4	6	8	10
Bob (mg/lit)	11	18	22	24	26

[18]

OR

Q8) a) Draw a labelled diagram of Activated sludge process.
b) Explain :
i) Volumetric loading rate.
ii) Hydraulic retention time.
iii) Recycle ratio.

[18]

Q9) Write short notes on :

[16]

- Oxygen sag curve.
- Photo catalytic reactors.

OR

Q10) a) Explain advanced wastewater treatment in detail.
b) Discuss about Ion-Exchange method.

[16]

Q11) a) What are the sources & classification of solid waste.
b) Explain sanitary land filling.

[16]

OR

Q12) a) Write in brief about Nitrification & de Nitrification.
b) Discuss in detail about composting.

[16]

* * *

Total No. of Questions : 12]

SEAT No. :

P1262

[Total No. of Pages : 3

[4164]-192
B.E. (Chemical)
PROJECT COSTING AND APPRAISAL
(2003 Pattern) (Sem. - II)

Time :3 Hours]

[Max. Marks :100

Instructions to the candidates:

- 1) *Answer three questions from each section.*
- 2) *Answers to the two sections should be written in separate books.*
- 3) *Neat diagrams must be drawn wherever necessary.*
- 4) *Figures to the right indicate full marks.*
- 5) *Use of logarithmic tables, slide ruler, Mollier charts, electronic pocket calculator and steam tables is allowed.*
- 6) *Assume suitable data if necessary.*

SECTION - I

- Q1)** a) Explain the concept of market survey and compare it with market research. **[8]**
- b) What is meant by project evaluation? **[8]**

OR

- Q2)** Explain the terms in detail : **[16]**
- a) Supply and demand.
 - b) Concept of cost.
 - c) Margin.
 - d) Profit.

- Q3)** a) Discuss the statement of income and expenditure in detail. **[8]**
- b) The annual direct production costs for a plant operating at 70 percent capacity are Rs. 2,80,000 while the sum of the annual fixed charges, overhead costs, and general expenses is Rs. 2,00,000.

What is the break-even point in units of production per year if total annual sales are Rs. 5,60,000 and the product sells at Rs. 40 per unit?

P.T.O.

What were the annual gross earnings and net profit for this plant at 100 percent capacity when corporate income taxes required a 15 percent tax on the first Rs. 50,000 of annual gross earnings.

25 percent on annual gross earnings of Rs. 50,000 to Rs. 75,000.

34 percent on annual gross earnings above Rs. 75,000, and 5 percent on gross earnings from Rs. 1,00,000 to Rs. 3,35,000. [8]

OR

Q4) a) Discuss with example the concept of journal and ledger entries. [8]

b) Explain the balance sheet with detailed analysis. [8]

Q5) a) What are the basic factors involved in equipment costing? [8]

b) Explain the terms : [10]

i) Basic concept of cost.

ii) Prime cost.

OR

Q6) a) Calculate in detail the cost of any heat exchanger of your choice giving details about technical specifications and costing of the equipment. [8]

b) Explain how the allocation of over heads of various cost elements is worked out. [10]

SECTION - II

Q7) a) Write in detail about various methods for raising the finance. [8]

b) Explain the terms : [8]

i) Fixed Capital.

ii) Working Capital.

OR

Q8) It is desired to borrow Rs. 1,000 to meet a financial obligation. This money can be borrowed from a loan agency at a monthly interest rate of 2 percent. Determine the following : [16]

a) The total amount of principal plus simple interest due after 2 years if no intermediate payments are made.

b) The total amount of principal plus compounded interest due after 2 years if no intermediate payments are made.

c) The nominal interest rate when the interest is compounded monthly.

d) The effective interest rate when the interest is compounded monthly.

- Q9)** a) Explain in detail cash flow diagram. [8]
b) Explain the concept of taxes and their types. [8]

OR

- Q10)** Explain the terms : [16]
a) Cash flow statement.
b) Discount cash flow.
c) Need for expansion & diversification.
d) Capitalized cost.

- Q11)** a) Define depreciation and discuss its need and significance with limitations. [8]
b) Discuss various methods of determining depreciation charge. [10]

OR

Q12) The original value of a piece of equipment is Rs. 22,000 completely installed and ready for use.

Its salvage value is estimated to be Rs. 2,000 at the end of a service life estimated to be 10 years.

Determine the asset (or book) value of the equipment at the end of each year using : [18]

- a) Straight-line method.
b) Textbook declining-balance method.

* * *

Total No. of Questions : 12]

SEAT No. :

P1263

[Total No. of Pages : 2

[4164]-193
B.E. (Chemical)
CHEMICAL PLANT ENGINEERING
(2003 Pattern) (Sem. - II)

Time :3 Hours]

[Max. Marks :100

Instructions to the candidates:

- 1) Answer any three questions from each section.*
- 2) Answers to the two sections should be written in separate books.*
- 3) Neat diagrams must be drawn wherever necessary.*
- 4) Figures to the right indicate full marks.*
- 5) Use of logarithmic tables, slide rule, Mollier charts, electronic pocket calculator and steam tables is allowed.*
- 6) Assume suitable data, if necessary.*

SECTION - I

- Q1)** a) What is process flow diagram?
b) Explain the importance of flow sheeting in a chemical process industry. **[16]**

OR

- Q2)** a) What is the importance of laboratory data?
b) What are the scale up methods? Explain. **[16]**
- Q3)** Discuss in detail the techno economic feasibility report of a petrochemical industry. **[18]**

OR

- Q4)** a) Discuss the various factors affecting the site location.
b) What is thermodynamic feasibility and kinetic feasibility? Explain with example. **[18]**
- Q5)** What are the primary and secondary process utilities required for chemical industry? **[16]**

OR

- Q6)** Explain Primary, Secondary and Tertiary wastewater treatment in detail, with neat sketch. **[16]**

P.T.O.

SECTION - II

- Q7)** a) What is normal pipe size?
b) Explain the details of colour codes for piping. **[16]**

OR

- Q8)** Write short notes on : **[16]**
a) Pipe routing.
b) Pipe expansion & contraction.

- Q9)** a) Give the classification of pumps and explain the principle, construction and working of centrifugal pump. **[10]**
b) Describe the performance curve for centrifugal pump. **[8]**

OR

- Q10)** a) Explain single acting & double acting reciprocating pump with neat diagram. **[10]**
b) Explain the routine & preventive maintenance of a chemical plant during shut down. **[8]**

- Q11)** Write short notes on : **[16]**
a) CPM.
b) PERT.

OR

- Q12)** Write short notes on : **[16]**
a) HAZOP.
b) Risk Analysis.

Total No. of Questions : 12]

SEAT No. :

P1264

[Total No. of Pages : 2

[4164]-194
B.E. (Chemical)
PROCESS MODELING & SIMULATION
(2003 Pattern) (Sem. - II)

Time : 3 Hours]

[Max. Marks : 100

Instructions to the candidates:

- 1) *Answer any three questions from each section.*
- 2) *Answers to the two sections should be written in separate books.*
- 3) *Neat diagrams must be drawn wherever necessary.*
- 4) *Figures to the right indicate full marks.*
- 5) *Use of logarithmic tables, slide rule, Mollier charts, electronic pocket calculator and steam tables is allowed.*
- 6) *Assume suitable data if necessary.*

SECTION - I

- Q1)** a) What is model? What is process model?
b) Write the classification of models? **[16]**

OR

- Q2)** a) What are linear & nonlinear models? Explain with suitable examples.
b) What is the key difference between the independent variable and the dependent variable? **[16]**

- Q3)** a) Is it possible to obtain the steady state model from the given dynamic model of process? If yes, how?
b) What is the main difference between the lumped parameter model and the distributed parameter model? Explain with proper examples. **[16]**

OR

- Q4)** The following equation shows a material balance around a chemical reactor

$$0 = \frac{F}{V} C_{in} - \frac{F}{V} C - KC^3$$

where $\frac{F}{V} = 0.1 \text{ min}^{-1}$, $C_{in} = 1.0 \text{ kg mol/m}^3$,

$$K = 0.05 \text{ m}^6 / \text{kg mol}^2 \cdot \text{min}.$$

P.T.O.

- a) How many steady state solutions are there?
b) Write two different direct substitution methods & assess the convergence of each. [16]

Q5) Develop a process model for double pipe heat exchanger. [18]

OR

Q6) Develop a model for shell & tube heat exchanger. Take suitable assumptions. [18]

SECTION - II

Q7) Develop a mathematical model for an ideal binary distillation column considering two partially vaporized feed streams. One is fed on 5th tray and other is introduced on 10th tray. The same assumptions and equipment configurations, should be match. [18]

OR

Q8) Develop a mathematical model for multicomponent distillation column, assume suitable assumption. [18]

Q9) Develop a mathematical model for plug flow reactor. Write assumptions. [16]

OR

Q10) Develop mathematical model for Bioreactor. [16]

Q11) a) Write the applications of modeling & simulation in distillation.
b) What are the types of simulation? Explain. [16]

OR

Q12) Write different process simulation softwares, and discuss ASPEN PLUS in detail. [16]

* * *

Total No. of Questions : 12]

SEAT No. :

P1265

[Total No. of Pages : 3

[4164]-200

B.E. (Chemical)

FUEL CELL TECHNOLOGY

(2003 Pattern) (Elective - II) (Sem. - II)

Time :3 Hours]

[Max. Marks :100

Instructions to the candidates:

- 1) Answer 3 questions from Section - I and 3 questions from Section - II.
- 2) Answers to the two sections should be written in separate books.
- 3) Neat diagrams must be drawn wherever necessary.
- 4) Use of logarithmic tables, slide rule, Mollier charts, electronic pocket calculator and steam tables is allowed.
- 5) Assume suitable data, if necessary.

SECTION - I

- Q1)** a) Describe the Molten carbonate fuel cell with respect to processing, catalyst and fuel. [9]
- b) Describe the Solid oxide fuel cell with respect to processing, catalyst and fuel. [9]

OR

- Q2)** a) Discuss the advantages and limitations of fuel cell operating at low and high temperature respectively, taking the example of PEM and SOFC. [9]
- b) Explain the feasibility of application of fuel cell vehicles vs battery operated vehicles in transportation. [9]

- Q3)** Gibbs free energy for the formation of water vapor is -55.14 cal/mol at STP. In the typical SOFC, pure methane is fed at the pressure of 3 atm. Total pressure of gases on anodic side of fuel cell is observed to be 3.5 atm. Air is supplied at 1.2 atm. Fuel and air are supplied at the same operating temperature of 900 C. $\Delta G = 96486$ J/mol. Calculate [16]

- a) Standard open circuit potentials.
- b) Open circuit potential at the operating condition.
- c) What will be the effect if the operating temperature is increased to 1000C?

OR

P.T.O.

- Q4)** a) A current density of 15 A/m^2 is obtained when pure hydrogen is fed to SOFC at the pressure of 1.8 atm. Total pressure of gases at anodic side is observed to be 2.5 atm. Air is supplied at 1.8 atm. The cell is operated at 1000°C . The diffusion factors for hydrogen, oxygen and water vapor are 95, 70 and $55 \text{ C/s.m}^2 \text{ atm}$, respectively. Calculate concentration overpotentials across anode and cathode. [8]
- b) Calculate the fuel utilization factor, air ratio, power output and fuel efficiency of SOFC using the following data : [8]
- Average current density = 15 A/m^2
 Active anode surface area = 0.4 m^2
 Fuel flow rate = 25 mol/h
 Fuel composition = H_2 : 70% and CO: 30%
 Air flow rate = 20 mol/h
 Output potential = 230 V
 Lower heating value of the fuel = 250000 kcal/kg .

- Q5)** Derive the Nernst equation for calculating open circuit potential of SOFC using air as an oxidizer for the following conditions. [16]
- a) Pure butanol as fuel.
 b) H_2 as a fuel.

OR

- Q6)** Calculate material balance for SOFC generating 400 kW power at 80% CHP efficiency, using methane as fuel and 40% theoretical excess air as an oxidizer. [16]

SECTION - II

- Q7)** a) Discuss in detail defects in materials. Frenkel defects, Schottky defects. [8]
 b) Explain the defect equilibrium in solid structures. [8]

OR

- Q8)** a) Explain the mechanism of charge transfer in TPB. [8]
 b) What is steam reforming? What is its importance in SOFC? [8]

- Q9)** a) Design a tubular SOFC stack to generate 500 kW power for methane as a fuel. Single tube has anodic diameter of 18 mm and active length of 1.5 m. [8]
 b) Derive correlation to calculate defect mole fraction for pure solids at thermal equilibrium. [8]

OR

- Q10)** a) Derive the Butler-Volmer form of the charge transfer rates. [8]
b) Explain the mechanism of Direct oxidation of hydrocarbons in fuel cell. [8]

Q11) Develop a mathematical model for SOFC system using the anodic system of Ni, H₂-H₂O/YSZ. Hydrogen is used as a fuel and air as an oxidizer. Explain the: [18]

- a) Approach.
- b) Assumption
- c) Flow chart and
- d) Reaction.

OR

- Q12)** a) Explain the required characteristics of materials of construction of electrode, electrolyte and interconnect for SOFC. [9]
b) Design a planar SOFC to generate 300 kW power for ethanol as fuel. [9]

* * *

Total No. of Questions : 12]

SEAT No. :

P1266

[Total No. of Pages : 2

[4164]-200A
B.E. (Chemical)
PETROCHEMICAL ENGINEERING
(2003 Pattern) (Elective - II) (Sem. - II)

Time :3 Hours]

[Max. Marks :100

Instructions to the candidates:

- 1) Answers to the two sections should be written in separate books.*
- 2) Neat diagrams must be drawn wherever necessary.*
- 3) Figures to the right indicate full marks.*
- 4) Use of logarithmic tables, slide rule, Mollier charts, electronic pocket calculator and steam tables is allowed.*

SECTION - I

Q1) Discuss in detail about the main building blocks of Petrochemical Industry. **[16]**

OR

Q2) What are various types of crude oil distillation. Draw neat process diagram for synthesizing naphtha, diesel oil and lubricants. **[16]**

Q3) What are hydrocarbons. Write down the classification of hydrocarbons. **[18]**

OR

Q4) Write in details about various methods of production of aromatics. **[18]**

Q5) a) What is cracking. What are the different types of cracking. **[8]**

b) What are the effects of operating variables on thermal cracking. **[8]**

OR

Q6) Write in details about various separation and purification techniques used in petrochemical processes. **[16]**

P.T.O.

SECTION - II

Q7) With suitable flow diagrams, explain the production of amines. **[18]**

OR

Q8) a) What are the different available processes for glycol manufacture. Explain ethylene glycol manufacture. **[12]**

b) Explain the production method for dimethyl Ketone using propylene as the starting material. **[6]**

Q9) Write short notes on various types of polymerization processes. **[16]**

OR

Q10) Discuss polymer synthesis and monomer purification in detail. **[16]**

Q11) Discuss in detail various safety aspects in petrochemical plants. **[16]**

OR

Q12) a) Explain one case study for control of pollution in petrochemical complex. **[10]**

b) Discuss various pollution control norms for petrochemical plant. **[6]**

* * *

Total No. of Questions : 10]

SEAT No. :

P1267

[Total No. of Pages : 3

[4164]-202
B.E. (Petroleum Engineering)
PETROLEUM EXPLORATION
(2003 Pattern) (Sem. - I)

Time :3 Hours]

[Max. Marks :100

Instructions to the candidates:

- 1) *Answers to the two sections should be written in separate books.*
- 2) *Neat diagrams must be drawn wherever necessary.*
- 3) *Figures to the right indicate full marks.*
- 4) *Assume suitable data, if necessary.*

SECTION - I

Q1) Answer any two questions of the following : **[20]**

- a) What is a gravimeter? What are the types of gravimeter? Explain the construction of Lactose Romberg Gravimeter.
- b) Calculate the Bouger Anomaly for following data collected during the gravity survey along a line in an area (1° is a base station)
Given : Tidal Correction: 0.01 mgal, Terrain Correction: 0.031 mgal
 $\rho = 2.75$ gm/cc constant in a region. The Latitude of a line is 23°39'40"

Station	Time in hrs.	g obs mgal	Elevation in meter
1°	9.01	98136891	0
2	9.10	98136903	150
3	9.21	98136925	175
4	9.40	98136950	125
5	9.50	98136930	100
1°	10.07	98136899	0

- c) Explain the construction and working of flux gate magnetometer.
- d) Draw and discuss the effects produced by following conditions in gravity and magnetic survey.
 - i) A buried sphere of uniform radius 'r' at a depth 'z' with density higher than surrounding.
 - ii) A faulted horizontal sheet with thickness 't', occurring at a depth Z_1 and Z_2 , (where $Z_1 > Z_2$), with density higher than surrounding and angle of faulting $\theta = 45^\circ$ and also $\theta = 90^\circ$.

P.T.O.

- Q2)** a) Draw and explain Schlumberger arrangement of electrical resistivity survey. [6]
b) How is apparent resistivity different from true resistivity? [4]
c) Explain the “Expanding Spread Traverse” using Schlumberger method. [5]

OR

- Q3)** a) Explain the working principle of Geiger Muller Counter. [9]
b) The Nickel isotope ${}^{65}_{28}\text{Ni}$ decays by beta decay to the non-radioactive isotope of copper ${}^{65}_{29}\text{Cu}$. The half-life of the nickel isotope is 2.52h. An initially pure sample of ${}^{65}\text{Ni}$ contains 5.27×10^{20} atoms. How much time will pass until 8.37×10^{19} atoms of ${}^{65}\text{Cu}$ have been created? [6]

- Q4)** a) How is geochemical method effectively used as an exploration tool in new areas? [6]
b) Give different modes of transport of hydrocarbons through the seal of the reservoir to the surface. [9]

OR

- Q5)** Write short notes on : [15]
a) Geochemical Correlation Methods.
b) Weathering processes of Petroleum Seepages.

SECTION - II

- Q6)** Write short notes on (any two) : [20]
a) Normal Move out and Dip move out.
b) Time lapse seismic.
c) AVO,
d) Data noise in reflection survey.

OR

- Q7)** a) Explain the CDP method of seismic reflection survey using suitable diagram. [10]
b) To evaluate the prospect for hydrocarbons in a sedimentary basin, seismic reflection survey was conducted using a split spread arrangement record. Calculate the dip moveout for a dipping reflector using following data generated during the survey. Draw the relevant graph of Distance in (m) Vs Time in ms. [10]

Given:

- i) Velocity : 1800 m/s,
- ii) Thickness : 35 m,
- iii) Dip amount : 12°

Geophone	Distance m	Time in ms	Geophone	Distance m	Time in ms
12	36	49.09	05	15	42.18
11	33	47.91	04	12	41.49
10	30	46.79	03	9	40.88
09	27	45.73	02	6	40.36
08	24	44.74	01	3	39.94
07	21	43.81	Source	0	39.61
06	18	42.96			

- Q8)** a) What are “Seismic facies”? How are they mapped? [10]
b) Explain deterministic and probabilistic approach in risk analysis. [5]

OR

- Q9)** Five independent prospects are recognized in the leased area. Explain the interdependency between source, migration, trap, seal and reservoir parameters required in the understanding of risk analysis? [15]

- Q10)** How one may proceed for exploration of hydrocarbons taking into consideration basin classification and history of occurrence of hydrocarbons? [15]

* * *

Total No. of Questions : 9]

SEAT No. :

P1268

[Total No. of Pages : 2

[4164]-203

B.E. (Petroleum Engineering)

PETROLEUM FORMATION EVALUATION

(2003 Pattern) (Sem. - I)

Time :3 Hours]

[Max. Marks :100

Instructions to the candidates:

- 1) *Answers to the questions of both the sections should be written in separate answer books.*
- 2) *All questions are compulsory.*
- 3) *Draw neat diagrams wherever necessary.*

SECTION - I

Q1) Answer the following in brief :

- a) List five petrophysical data sources. [3]
- b) Distinguish between static and dynamic model of a reservoir. [2]
- c) What is mud logging? [3]
- d) What are the data sources in mud logging? [2]
- e) List the information obtained from conventional core analysis for the benefit of (i) petrophysicist (ii) geologist (iii) reservoir engineer (iv) production engineer. [4]
- f) Distinguish between wireline logging and LWD. [2]
- g) List four important applications of cased hole logging. [2]
- h) List the methods to study changes in Petrophysical parameters over time, used for reservoir monitoring. [2]

Q2) Describe borehole environment. What is invasion profile? Explain empirical relationship between different zones and fluids. Which logs are influenced most by the nature of invasion profile? [15]

OR

Q3) Explain important electrical logging methods with the help of neat sketches. [15]

P.T.O.

- Q4)** Write notes on any two of the following : **[15]**
- a) Logs used for evaluation of cementation,
 - b) MWD,
 - c) Radioactivity logs,
 - d) Sonic log.

SECTION - II

- Q5)** Outline the procedure for determination of water saturation using logs. **[20]**

OR

- Q6)** Write notes on any four of the following : **[20]**
- a) Applications of dipmeter logging,
 - b) Waxman and Smit Model,
 - c) Origin of over pressure,
 - d) Recognition of fractured reservoir,
 - e) Bullet Perforation
 - f) Density Log.

- Q7)** What is production logging? Explain important production logging methods. **[15]**

OR

- Q8)** Explain the importance core analysis. Explain 'special core analysis'. How does it help in formation evaluation? **[15]**
- Q9)** How will you recognize various depositional environments using logs? Explain with appropriate sketches. Draw sketches to explain. **[15]**

Total No. of Questions : 8]

SEAT No. :

P1269

[Total No. of Pages : 2

[4164]-205

B.E. (Petroleum Engineering)

REFINING AND PETROCHEMICAL TECHNOLOGY

(2003 Pattern) (Elective - I) (Sem. - I)

Time :3 Hours]

[Max. Marks :100

Instructions to the candidates:

- 1) *Answer any three questions from each section.*
- 2) *Answers to the two sections should be written in separate books.*
- 3) *Neat diagrams must be drawn wherever necessary.*
- 4) *Figures to the right indicate full marks.*

SECTION - I

- Q1)** a) Describe with flow sheet the dehydrogenation process for conversion of isopropanol to acetone. [12]
b) Write a note on composition of petroleum. [6]
- Q2)** a) Describe with flow sheet the process of catalytic hydrodesulfurization.[10]
b) Write a note on catalytic reforming. [6]
- Q3)** a) Describe with flow sheet any one process for manufacturing isopropyl alcohol. [10]
b) Mention end uses of ethylene glycol, methanol and acetone. [6]
- Q4)** a) Describe with flow sheet the process for preparation of ethylene oxide from ethylene and oxygen. [10]
b) Write a note on petroleum coke. [6]

SECTION - II

- Q5)** a) Describe with flow sheet the absorption method for production of LPG. [12]
b) Mention health and handling precautions and applications of acetic acid.[6]

P.T.O.

- Q6)** a) Describe with flow sheet the process for conversion of ethyl benzene to styrene. [10]
b) Explain with significance : [6]
i) API gravity.
ii) Cloud point.
- Q7)** a) Describe with flow sheet the process for conversion of methanol to acetic acid by carbonylation. [10]
b) Explain the terms pour point and smoke point along with significance. [6]
- Q8)** a) Write a note on catalytic cracking. [6]
b) Write a note on solvent dewaxing and ketone dewaxing of crude oil. [5]
c) Explain the process of bitumen blowing. [5]

* * *

Total No. of Questions : 10]

SEAT No.:

P1270

[Total No. of Pages : 2

[4164]-207

B.E. (Petroleum Engineering)

**ENVIRONMENTAL TECHNOLOGY IN PETROLEUM INDUSTRY
(2003 Pattern) (Elective - I) (Sem. - I)**

Time : 3 Hours]

[Max. Marks : 100

Instructions to the candidates:

- 1) Answers 3 questions from each section.*
- 2) Question 5 and question 10 are compulsory.*
- 3) Answers to the two sections should be written in separate books.*
- 4) Neat diagrams must be drawn wherever necessary.*
- 5) Figures to the right indicate full marks.*
- 6) Use of non programmable electronic pocket calculator is allowed.*
- 7) Assume suitable data, if necessary.*

SECTION - I

- Q1)** a) Discuss how petroleum industry contributes for Air Pollution. [4]
b) Why gas flaring is done? How it creates impact on environment? How it contributes to GHG emission? [6]
c) How man had impacted on environment with respect to Land, water and Air Pollution? [6]

OR

- Q2)** a) What are the methods used for treatment of hazardous material created because of petroleum industry? [8]
b) How pollution creates effects in overall Ecosystem? Discuss it with help of examples. [8]
- Q3)** a) Discuss the nature of common discharges from offshore and on shore petroleum rigs. [8]
b) What are physical principles used in following equipment plate condensers, Gas/Air filtration units, hydro cyclones, skim pipes. [8]

OR

- Q4)** a) What are the potential impacts found because of off shore and on shore discharge on environment? [8]
b) How Accidental discharges of petroleum fields creates impact on to environment? [8]

P.T.O.

- Q5)** a) Design skimmer TPI std. tank followed by DGF and (20 mg/lit) skim pile.
 Input = 50,000 bbl/day
 Maximum = 2% oil
 Oil = 40° API and 20° API
 Water salinity = 35,000 ppm
 Rainfall = 2 inch/hr
 Deck area = 1000m²
 (Finding d_m is discretionary) [10]
- b) What are the Indian standards for discharge of effluent in offshore and on shore site? [8]

SECTION - II

- Q6)** a) Write details on ISO 14000. [8]
 b) Write in details about well plugging with neat sketches. [8]

OR

- Q7)** a) Discuss the procedure of well abandonment in details. [8]
 b) Write merits and demerits of FMEA, JSA, what-if analysis? [8]
- Q8)** a) Elaborate on various safety aspects during drilling, logging, production, transportation, handling etc at onshore and offshore sites. [10]
 b) Discuss the various models of HSE management. [6]

OR

- Q9)** a) Elaborate on salient provisions in the oil mines regulation act in India related to management, drilling, production and transport. [10]
 b) Discuss in details about Emergency Response Plan. [6]
- Q10)** a) What are limitations of BOD test? Can we determine BOD of wastewater if we know the COD? What are the conditions needs to follow. [8]
 b) Discuss the any one case study on accident in petroleum industry because of insufficient care of HSE rules. [10]



Total No. of Questions : 6]

SEAT No.:

P1271

[Total No. of Pages : 7

[4164]-211
B.E. (Petroleum Engineering)
PETROLEUM ECONOMICS
(2003 Pattern) (Elective - II) (Sem. - II)

Time : 3 Hours]

[Max. Marks : 100

Instructions to the candidates:

- 1) *Answers to the two sections should be written in separate books.*
- 2) *Question. 1 and 6 are compulsory. Attempt any one question from other questions each from section I and II.*
- 3) *Use of graph paper is allowed.*
- 4) *Figures to the right indicate marks.*
- 5) *Assume additional data, if necessary.*

SECTION - I

Q1) a) Details of production profile and expenditure required are given in the following table for a field under consideration for procurement. **[15]**

YEAR	Oil production, Million barrel/year	E and D cost, \$ Million	Production cost, \$ Million
1		25.3	
2		25.3	
3		25.3	
4		25.3	
5		250.6	
6	4.562	250.6	27.4
7	6.843		41.5
8	9.122		54.3
9	9.123		54.3
10	9.124		54.3
11	9.126		54.3
12	9.126		54.3
13	9.126		54.3
14	9.126		54.3
15	7.698		46.7
16	6.495		38.5
17	5.479		32.2
18	4.623		27.8
19	3.905		23.9
20	3.292	60	19.4

P.T.O.

Plot the available production data on semi log paper and find out graphically and also numerically the pattern of declining in production. What is the OOIP if original recovery of oil was 23%? If additional 8% recovery is anticipated then what is the value of reservoir to be recovered?

b) Write a note on production and demand of hydrocarbons in India. [10]

Q2) a) Current oil price in international market is \$ 80.25. It is anticipated that the price will increase at a rate of general inflation, which is forecast to be at the rate of 6.30% per year for first three years and then drop to an annual rate of 4.75% thereafter.

The producible in the block has lower API than that brand oil along with higher sulphur and TAN content, thus leading to a price differential of 10.25% with respect to the oil price quoted above.

Develop a forecast for oil price for brand oil and the oil under consideration for a span of eight years. [9]

b) Write notes on Any Two of the following : [16]

i) Resource classification system recommended by SPE.

ii) Factors controlling oil pricing in international market.

iii) Reserves auditing.

iv) Reserves accretion and discovery of field size scenario in past 20 years.

- Q3) a)** Figure given below shows that the well has produced at a constant rate of 200 BOPD for 4 years. The production then declined exponentially over the next 16 years to an economic limit of 5 BOPD. The company demands a minimum ROR of 10% and oil from this field is \$ 3.15/bbl. net after local taxes, royalty and operating expenses. **[15]**

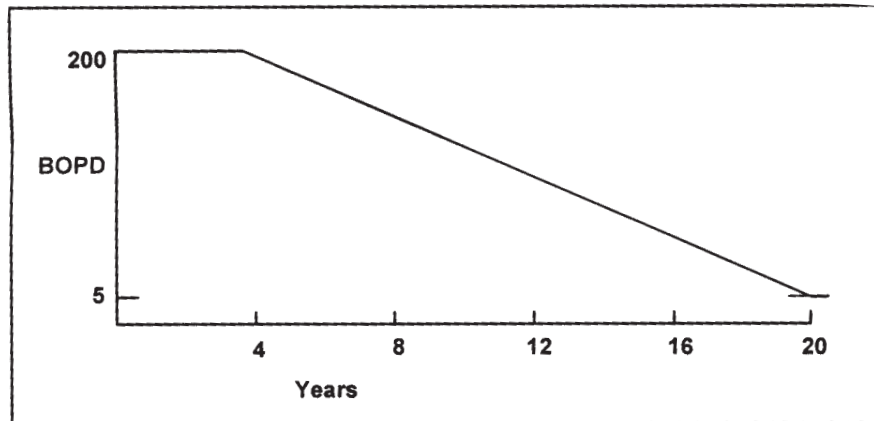

Calculate a composite NPV of a barrel of oil using annual compounding. Assume that NPV of decline production, as of start of decline, is \$ 4,50,000.00.

- b) Write notes on Any Two of the following : **[10]**
- i) Incremental Investment Analysis.
 - ii) Investment Yardsticks.
 - iii) Sensitivity Analysis.
 - iv) Oil price elasticity.
 - v) Reserves to Production ratio (R/P).

SECTION - II

- Q4)** a) A wildcat well is being considered in a relatively unknown but highly promising area. Available data indicates that three separate horizons independent from one another would most possibly be producing.

Create a decision tree for the success and failure for the horizons (X, Y, and Z) to illustrate the probability of occurrence of these events with possible outcome of events. **[15]**

- b) Company A owns complete Working Interest (W.I.) for a petroliferous basin. For some reason A leases its land for oil and gas development to D, retaining its 1/8 royalty interest. In order to hedge against non-productive development A sells 1/4th of its royalty to B and 1/8th of its royalty to C. D, the original lessee, then conveys the lease to E, retaining 1/16th of 7/8 Overriding Royalty Interest (ORI). To support D with its development and operating cost, E now sells one-fourth of its interest in the lease to F.

A, B, C, D, E and F, thus, become the royalty owners for the hydrocarbon development project.

Calculate the Overriding Royalty Interest (ORI) and Working Interest (W.I.) for each of them. **[10]**

- Q5)** a) Write notes on Any Two of the following : **[10]**
- i) Profitability in projects and equivalence of field size in different countries within the framework of production Fiscal System.
 - ii) Petroleum Accounting System.
 - iii) Risk analysis applied to petroleum field development.
 - iv) Variation in technical costs of exploration and production of oil and gas as a function of water depth and geographic location.

- b) The management of an oil and gas company is analysing a drilling prospect from a known hydrocarbon area. However the most important aspect in the discussion is finding of hydrocarbon reserves. The field has a history of occurrence of reserves of gas of 2 BCF in 40% wells, 3 BCF in 30% wells, 4 BCF in 20% and 5 BCF in 10% wells.

The probability of finding of gas is 0.30 and if gas is encountered then probability of finding of reserves of 2 BCF, 3 BCF, 4 BCF and 5 BCF is identical to that of success ratio encountered in the field. Monetary profits for each level of reserves if encountered are given for two available alternatives, drilling or farm out.

Reserves	NPV, if drilled	NPV profit, if farmed out
2 BCF	\$ + 40,000	\$ + 9,000
3 BCF	\$ + 90,000	\$ + 12,500
4 BCF	\$ + 1,30,000	\$ + 15,000
5 BCF	\$ + 2,00,000	\$ + 18,000

What is the best choice in this prospect based on maximizing EMV? What is the minimum probability of finding gas required to justify even the risk of drilling?

Draw a graph of EMV and probability of finding gas and show the intersecting point where the decision is reversed. Show all calculations.

Construct decision tree at a suitable step, show all calculations and take decisions with proper justification. [15]

Q6) a) Use data given in question 1.A. to solve this question. **[20]**

Prepare a tabular form of the data, given in question I, giving details of annual production, cumulative production, gross cash flow, royalty, net cash flow BFIT and AFIT, government share and contractor share, NPV for contractor BFIT and AFIT.

Following are the assumptions for the preparation of spreadsheet and further calculations :

- i) Oil price is \$ 80 per barrel and will remain constant throughout the project tenure.
- ii) Royalty is 10% of annual revenue/annual production.
- iii) Time value of money is 10%
- iv) Cost recovery is 60%, and remaining cost is allowed to carry forward for next year.
- v) Profit petroleum is shared between government and contractor at 60:40 proportions respectively.
- vi) Income tax is 30%.

Calculate the contractors NPV before tax and after tax.

Show how one barrel of oil or \$ 80 is distributed using the assumptions given above?

How much is the profit for contractor in one barrel and what is the total revenue generation for government in the calculation of one barrel?

- b) An oil company has mapped a prospect and concluded that the resources may be as high as 50 million barrels and the probability of success (POS) is estimated to be 10%. **[5]**

The data acquired, the interpretations and the cost of the exploration well will amount to 20 million USD. If a discovery is made, the NPV will be 90 million USD.

- i) Calculate the expected monetary value.
- ii) Find the break even POS.



Total No. of Questions : 10]

SEAT No.:

P1272

[Total No. of Pages : 3

[4164]-224
B.E. (Petrochemical)
PROCESS DYNAMICS AND CONTROL
(2003 Pattern) (Sem. - I)

Time : 3 Hours]

[Max. Marks : 100

Instructions to the candidates:

- 1) *Answer any 3 questions from each section.*
- 2) *Answers to the two sections should be written in separate books.*
- 3) *Figures to the right indicate full marks.*
- 4) *Use of logarithmic tables, slide rule, Mollier Charts, electronic pocket calculator and steam table is allowed.*
- 5) *Assume suitable data, if necessary.*

SECTION - I

- Q1)** a) What are incentives of Chemical Process Control? Explain with help of suitable example. **[8]**
- b) Develop the mathematical expressions of two non-interacting tanks placed in series. Discuss the dynamics of the system. **[8]**

- Q2)** Dynamics of a system can be represented by following set of equations : **[16]**

$$\frac{dx_1}{dt} = x_1 + 3.9x_2 \quad \text{with } x_1(0) = 0$$

$$\frac{dx_2}{dt} = 2x_1 + x_2 + 3.8 \quad \text{with } x_2(0) = 0$$

- a) Obtain corresponding algebraic equations using Laplace Transform.
 - b) Solve obtained algebraic equations using Cramer's rule.
 - c) Use Heaviside expansions for the roots and subsequently report the solutions in time domain.
- Q3)** a) Define following with help of neat diagrams : **[10]**
Decay Ratio, Damping Factor, Rise Time, Response Time, Gain.
- b) With help of neat sketch explain the proportional, derivative and integral modes of a PID controller. **[8]**

P.T.O.

- Q4)** a) Discuss Servo and Regulatory control problems with diagrams. [8]
 b) Find the overall transfer function of the following system : [8]

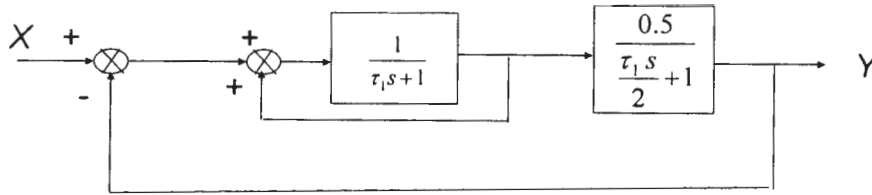

- Q5)** a) Derive the mathematical expression of a simple U-tube manometer. Comment on dynamics of the system. Obtain the transfer function as well. [8]

- b) Density of an ideal gas is function of pressure and temperature and can be represented by : $\rho = \frac{M p(t)}{RT(t)}$, where symbols have their usual

significances.

- Derive the overall linearized function for density (ρ).
- If $M = 98$, $T = 376$ K, $p = 211.3$ kPa and $R = 8.314$ (kPa.m³)/(kmol.K), obtain the density.
- Calculate density of the gas at 104.2 kPa and 120°C temperature with help of derived linearized equation. [8]

SECTION - II

- Q6)** a) What are different time - integral performance criteria generally used for Controller Tuning? Explain in brief. [6]
 b) Explain PLC based control and cite its advantages. [6]
 c) With help of suitable example explain the application of Feedforward in the Petrochemical Complex. [6]

- Q7)** a) Plot the root locus diagram for the following process : [8]

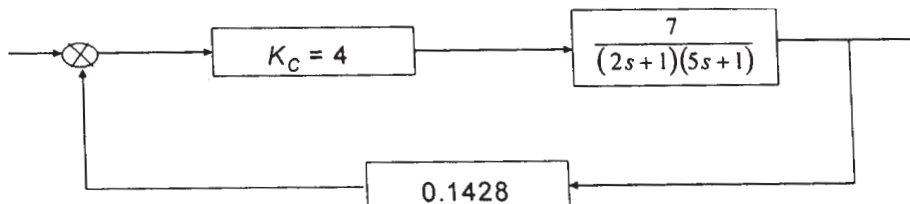

b) Consider a feedback control system having the characteristic equation.

$$s^3 + 2s^2 + (2 + K_c)s + \frac{K_c}{\tau_I} = 0$$

- i) Derive condition of stability for the system with help of Routh-Hurwitz Criterion.
- ii) If $K_c = 38$ and $\tau_I = 0.3$, comment on stability. [8]

- Q8)** a) What type of feedback controller should be used to control a given process? [4]
- b) What are the performance criteria to be used for selection and tuning of the controllers? [4]
- c) With help of neat diagram explain cascade control on distillation column. [8]

- Q9)** a) Calculate Amplitude Ratio and Phase Angle for overdamped 2nd order system with transfer function : $G(s) = \frac{4}{(0.8s+1)(2s+1)}$. [8]

b) Draw Bode plots for an open-loop process, whose dynamics can be represented by : [8]

$$G_{OL} = 25K_c \left(\frac{1}{11s+1} \right) \left(\frac{1}{5s+1} \right)$$

The value of Gain K_c can be assumed to be 0.6.

Q10) Write short notes on (Any Four) : [16]

- a) Principles of Digital Control.
- b) Plant-wide Control System.
- c) Field Bus Technology.
- d) Z - Transform and its Utility.
- e) Split Range Control.
- f) SCADA operation in Modern Refinery Complex.



Total No. of Questions : 10]

SEAT No.:

P1273

[Total No. of Pages : 2

[4164]-225
B.E. (Petrochemical Engineering)
ENVIRONMENTAL ENGINEERING
(2003 Pattern) (Elective - I) (Sem. - I)

Time : 3 Hours]

[Max. Marks : 100

Instructions to the candidates:

- 1) *Answers any 3 questions from each section.*
- 2) *Answers to the two sections should be written in separate books.*
- 3) *Neat diagrams must be drawn, wherever necessary.*
- 4) *Figures to the right indicate full marks.*
- 5) *Use of electronic pocket calculator is allowed.*
- 6) *Assume suitable data, if necessary.*

SECTION - I

- Q1)** a) How man had impacted on environment with respect to Land, water and air pollution? [8]
b) How Gas flaring affects the environment? [6]
c) Discuss the types of biomedical waste. What are the methods of segregation of biomedical waste. [2]
- Q2)** a) What are the impacts of global warming on climatic change? [6]
b) Discuss the method of sanitary land filling and incineration with respect to solid waste management. [6]
c) Discuss any one wet collector along with its advantages and disadvantages. [6]
- Q3)** a) Elaborate on “Source correction methods for air pollution control”. [8]
b) How pollution creates effects in overall Ecosystem? Discuss it with help of examples. [8]
- Q4)** a) Discuss the construction and working of wet collectors and specifically for Ventury Scrubber. [8]
b) Discuss the impacts of Green House Effects. [4]

P.T.O.

- c) A high efficiency cyclone with diameter one meter handles $3\text{m}^3/\text{s}$ of standard air carrying particles with a density of $2000\text{kg}/\text{m}^3$. For effective number of turns $(N_e) = 6$, determine the cut size. What will be the cut size for a conventional cyclone? The viscosity of gas $(\mu_g) = 1.81 \times 10^{-5}\text{kg}/(\text{m}\cdot\text{s})$ the density of the gas. [4]

- Q5)** a) Discuss the construction, working, advantages and disadvantages of fabric filter and cyclone separator with respect to air pollution control. [8]
b) How H_2S is removed from sour gas is removed in petroleum industry. [4]
c) What are different factors on which selection of air pollution control equipment depends? [4]

SECTION - II

- Q6)** a) Write the detailed classification of solids found in waste water. [4]
b) Discuss about permanent and temporary hardness. How Temporary hardness can be removed? [8]
c) Discuss the sources of waste water. [6]

- Q7)** a) Discuss the various primary treatments available for waste water. [6]
b) Discuss the principle, construction and working of rotating biological contactors. [10]

- Q8)** a) Discuss how waste from fertilizer industry is treated. [8]
b) Discuss in detail about how liquid effluent from petrochemical complex is treated. [8]

- Q9)** a) Discuss the difference between aerobic and anaerobic digestion systems for wastewater treatment. [8]
b) Elaborate on difference between suspended growth and attached growth process. [8]

Q10) Write short note on following (Any Four) : [16]

- a) Role of adsorption in advanced waste water treatment.
b) Sludge treatment and disposal.
c) Biochemical Oxygen Demand.
d) Trickling filter.
e) Sludge volume index (with formula).



Total No. of Questions : 12]

SEAT No.:

P1274

[Total No. of Pages : 3

[4164]-230 - A
B.E. (Petrochemical)
CATALYSIS TECHNOLOGY AND FLUIDIZATION ENGINEERING
(2003 Pattern) (Elective - II) (Sem. - II)

Time : 3 Hours]

[Max. Marks : 100

Instructions to the candidates:

- 1) *Answer 3 questions from each section.*
- 2) *Answers to the two sections should be written in separate books.*
- 3) *Neat diagrams must be drawn, wherever necessary.*
- 4) *Figures to the right indicate full marks.*
- 5) *Use of logarithmic tables, slide rule, Mollier Charts, electronic pocket calculator and steam table is allowed.*
- 6) *Assume suitable data, if necessary.*

SECTION - I

- Q1)** a) Define and explain : Catalyst Selectivity, Turnover Number, Negative Catalyst. [6]
- b) Name various means and ways by which a catalyst can be deactivated - discuss all of them. [6]
- c) Write a short note on homogeneous catalysis. [4]

OR

- Q2)** a) With the help of neat sketch explain how catalyst changes reaction pathways. [8]
- b) Write a short note on Catalytic Adsorption, discuss various types of adsorption. In this context highlight importance of adsorption isotherm. With neat diagram explain hysteresis in adsorption. [8]
- Q3)** a) What is BET equation? Discuss its usefulness. Derive BET Isotherm with help of the important assumptions. [8]
- b) For the catalytic gas phase reaction : $X + Y \rightarrow Z$, derive the rate expression considering Langmuir-Hinshelwood mechanism in terms of partial pressure of the respective components. [10]

Note that all the reactants and products are adsorbed appreciably. If some inert gas Helium is also present, this is also strongly adsorbed on the surface, write down the modified rate expression.

P.T.O.

OR

Q4) The reaction $\text{CO} + \text{H}_2\text{O} \leftrightarrow \text{CO}_2 + \text{H}_2$ is carried out in an adiabatic fixed bed catalytic reactor. The composition of gas stream at entry is : CO 7.9%, CO_2 4.8%, H_2 34.4%, N_2 13.5% and H_2O 39.4% (all in molar basis).

The total flow rate is 8983 kmol/h and the diameter of the catalyst bed is 4m. Tests have shown that diffusion from bulk gas to the surface of the catalyst pellets does not limit the reaction rate. The reaction rate can be expressed in the form :

$$-r'_{\text{CO}} = A (f(T))^* (y_{\text{CO}} * y_{\text{H}_2\text{O}} - y_{\text{CO}_2} * y_{\text{H}_2} / K(T))$$

$$\text{where } f(T) = \exp(15.95 - (4900/T))$$

$$K(T) = \exp(-4.33 + (4578/T))$$

$A = 0.17$ kmol per hr. per m^3 of catalyst bed at the proposed operating pressure of 25.3 bar absolute.

Inlet temperature of reactor is 616.5 K.

- If isothermal conditions are maintained in the catalyst bed ($T = 616.5\text{K}$), calculate (dz/dX_{CO}) at points where the conversion of the CO in the bed (X_{CO}) is 0.0, 0.2, 0.4, 0.6 and 0.8 (z is the axial distance from the entry point of the bed).
- In the above isothermal situation calculate the bed depth required to achieve 80% conversion of the CO entering the bed. What fraction of the total depth is required to increase the conversion from 70% to 80%.

[18]

- Q5)** a) With help of suitable example explain acid-base catalyst. Discuss its mode of action. Provide industrial relevance of the same. [8]
- b) Discuss impregnation method of catalyst manufacture in details. [8]

OR

Q6) Write short notes on (Any Four) : [16]

- Dual Site Catalyst.
- Massive Metallic Catalysis.
- Characterization of Catalyst.
- Poisoning of Metal Catalysts.
- Industrial importance of Zeolite Catalyst.
- Catalysis for Pollution Abatement.

SECTION - II

- Q7)** a) With help of neat sketches explain liquid like behavior of a Fluidized Bed. [6]
b) Compare Fluidization with various other modes of contacting. [6]
c) Write a short note on quality of fluidization. [6]

OR

- Q8)** a) Differentiate between group of particles as classified by Geldart. Provide appropriate examples of each group. [10]
b) Compare advantages and Disadvantages of Fluidized Bed. [8]
- Q9)** a) With help of neat diagram discuss various types of gas distributor for fluidized bed - Compare their performances. [8]
b) Write short notes on Sintering and Agglomeration in Fluidized Bed. [8]

OR

- Q10)** a) In a fluidized bed, mixing is combined effort of plug flow and mixed flow mode-Explain with help of neat diagram. [8]
b) Explain the principle of immersed tube fluidized bed heat transfer medium. Discuss its advantages and disadvantages. [8]
- Q11)** a) Write down important assumptions of Kuni-Levenspiel model and discuss the model qualitatively. [8]
b) With help of schematic diagrams explain operations of various types of fluidized bed driers. [8]

OR

- Q12)** Write short notes on (Any Four) : [16]
- a) Fluidized bed Reactor for Polymerization.
 - b) Acrylonitrile Synthesis Reactor.
 - c) Bubble Movement through Fluidized Bed.
 - d) FCC Reactor.
 - e) Densed Bed Fluidization.
 - f) Pneumatic Conveying.



Total No. of Questions : 8]

SEAT No.:

P1275

[Total No. of Pages : 2

[4164]-230-B
B.E. (Petrochemical Engineering)
BIOCHEMICAL ENGINEERING
(2003 Pattern) (Elective - II) (Sem. - II)

Time : 3 Hours]

[Max. Marks : 100

Instructions to the candidates:

- 1) Answer any three questions from each section.*
- 2) Answers to the two sections should be written in separate books.*
- 3) Neat diagrams must be drawn, wherever necessary.*
- 4) Figures to the right indicate full marks.*

SECTION - I

- Q1)** a) What are carbohydrates? Mention about their classification and functions. **[10]**
b) What is enzyme technology? Mention important industrial applications of enzymes. **[8]**
- Q2)** a) Explain primary, secondary and tertiary structure of proteins. **[10]**
b) Explain the concept of biotechnology tree. **[6]**
- Q3)** a) Write notes on : **[15]**
i) Immobilization of enzymes.
ii) Lipids.
iii) Types of cells.
b) Define the term biotechnology. **[1]**
- Q4)** a) Differentiate between ribonucleic acid and deoxyribonucleic acid. Explain the terms nucleosides and nucleotides. **[10]**
b) Mention importance of microbiology in biochemical processes. **[6]**

SECTION - II

- Q5)** a) Discuss heat and mass transfer issues in fermenter design. **[8]**
b) Write a note on separation challenges in bioprocess engineering. **[8]**

P.T.O.

- Q6)** a) Discuss fermenter power requirement calculations. [8]
b) Write a note on monod kinetics. [8]

- Q7)** a) Discuss kinetic aspects of competitive and noncompetitive inhibition. [10]
b) Write a note on fermenter scale up. [6]

- Q8)** Substrate B and enzyme E flow through a CSTR having volume of 8.0 liters. From the inlet (C_{B0}) and exit (C_B) concentrations and flow rates given below, find a rate equation to represent the action of enzyme on substrate. [18]

C_{B0} mol/lit	C_B mol/lit	C_{E0} mol/lit	V lit/mol
0.3	0.06	0.03	4.5
0.45	0.23	0.015	6.0
1.04	0.9	0.002	1.8



Total No. of Questions : 12]

SEAT No.:

P1276

[Total No. of Pages : 3

[4164]-231
B.E. (Polymer)
POLYMER STRUCTURE AND PROPERTY RELATIONSHIP
(2003 Pattern) (Sem. - I)

Time : 3 Hours]

[Max. Marks : 100

Instructions to the candidates:

- 1) *Answers to section-I and section-II should be written on separate answer book.*
- 2) *Solve 3 questions from section-I and 3 questions from section-II.*
- 3) *Neat diagrams should be drawn, wherever necessary.*
- 4) *Figures to the right indicate full marks.*
- 5) *Assume suitable data, if necessary.*
- 6) *Use of electronic pocket calculator is allowed.*

SECTION - I

- Q1)** a) Comment on the Silicon atom and the bonds it forms with other atoms. [6]
b) Explain the effect of aliphatic and aromatic carbon-hydrogen bonds on the polymer properties. [6]
c) Comment on the factors those cause flexibility in elastomers. [6]

OR

- Q2)** a) Comment on the various bonds formed by Oxygen atom with other atoms. [6]
b) With suitable examples explain the effect of isocyanate linkage on the polymer properties. [4]
c) C-F bond is more polar than C-Cl bond. True or False? Justify your answer. [4]
d) Which bond imparts moisture absorption in Nylons? Explain its effect on properties of Nylon. [4]

- Q3)** a) Explain the importance of polarity in determining polymer properties. [6]
b) Why Tg of PTFE is very high? [4]
c) Secondary bonds like Hydrogen bonds affect thermal properties of polymer. Justify. [6]

OR

P.T.O.

- Q4)** a) With suitable examples explain how strengths of various bonds on affect polymer properties. [6]
 b) What are the factors those affect adhesion properties of given polymer? [6]
 c) Why isotactic PP has better mechanical properties compared to atactic polymers? [4]
- Q5)** a) Explain the significance of MW and MWD in determining polymer properties. [8]
 b) Why is it necessary to use various additives in polymer before converting into final product? Enlist various additives used in polymer formulation. [8]

OR

- Q6)** a) Enlist the factors which affect dielectric properties. [6]
 b) Explain the following terms - Dielectric constant, Dielectric loss, Dissipation factor, Surface resistivity, Volume resistivity. [10]

SECTION - II

- Q7)** a) Show that the free volume associated with polymer below its T_g is 2.5% of the total volume. [4]
 b) Processing conditions affect spherulite growth in PP, thereby, affecting properties. True or False. Justify your answer. [5]
 c) Explain Fringed Micelle Theory. [6]
 d) What do you understand by freedom of rotation of bonds? [3]

OR

- Q8)** a) Explain in detail how molecular flexibility affects polymer properties. Give suitable examples. [9]
 b) What do you understand by 1st and 2nd order transitions? Explain with neat sketches. [6]
 c) Explain what is meant by super-cooled state. [3]
- Q9)** a) Explain in detail the effect of kinetic factors on crystallinity. [8]
 b) Crystallinity affects the optical properties of polymers. Justify the statement. [5]
 c) Explain the role of symmetry on crystallinity. [3]

OR

- Q10)** a) Explain detail the effect of thermodynamic factors on crystallinity. [8]
 b) Orientation affects the polymer properties. Justify the statement with suitable examples. [8]

- Q11)** a) Explain the concept of Time-Temperature superposition in understanding polymer properties. [8]
- b) What is Intermolecular bonding? What are the various intermolecular bonds present in polymer? Explain any one in details. [8]

OR

- Q12)** a) What is WLF equation? Explain the various terms in the equation as well as their relevance. [8]
- b) Intermolecular bonds affect polymer properties. With suitable examples justify the given statement. [8]



Total No. of Questions : 12]

SEAT No.:

P1277

[Total No. of Pages : 2

[4164]-233
B.E. (Polymer Engineering)
POLYMER COMPOSITES AND BLENDS
(2003 Pattern) (Sem. - I)

Time : 3 Hours]

[Max. Marks : 100

Instructions to the candidates:

- 1) *Answers to the two sections should be written in separate books.*
- 2) *Draw neat diagrams wherever necessary.*
- 3) *Numbers to the right indicate full marks.*
- 4) *Assume suitable data, if necessary.*
- 5) *Use of logarithmic table, electronic pocket calculators is allowed.*

SECTION - I

- Q1)** a) Explain the terms : Polymer Blends, Polymer Alloy, Immiscible Polymer Blends, and Miscible Polymer Blends. **[8]**
- b) Explain different Polymeric Modifier used to improve the following properties such as Impact Strength, Chemical Resistance, Heat Deflection Temperature, Flame Resistance and barrier properties. **[8]**
- c) Discuss the importance of polymer blends. **[2]**

OR

- Q2)** a) Discuss the advantages and disadvantages of the following engineering polymeric modifier :
- i) Polycarbonate.
 - ii) Acrylonitrile Butadiene Styrene (ABS). **[8]**
- b) Discuss any two methods of preparation of polymer blends with examples. **[10]**
- Q3)** a) Explain the terms : Compatibilizer and Compatibilization. **[8]**
- b) Discuss with necessary diagram the effect of temperature on the Phase Stability. **[8]**

OR

- Q4)** a) Discuss the importance of Maleated Polymers in Polymer Blend Technology. **[8]**
- b) Discuss the role of critical molecular weight to achieve thermodynamic miscibility. **[8]**

P.T.O.

- Q5)** a) Explain the how to use known model system to predict rheology of immiscible polymer blends. [8]
b) Discuss the method of Interpenetrating Polymer Network with suitable examples. [8]

OR

- Q6)** Write a note on : [16]
a) Blends of Polystyrene (PS).
b) Blends of high density polyethylene (HDPE).
c) Toughened Polymer blend systems.
d) Rheological classifications of Polymer Blends.

SECTION - II

- Q7)** a) What is Reinforcement and list the different types and forms of the reinforcing materials? Compare the Aramide Fiber reinforcements with Boron Fiber Reinforcements. [10]
b) What are the selection criteria's used for Epoxy resin used in composites and list the various commercial grades of the same and brief about diluents used in epoxy resins. [8]

OR

- Q8)** a) Explain the role of Role of Mold release agent and Adhesion Promoters in composites. [8]
b) Write a note on "Curing Systems" used for polyester and epoxy resin based composites. [10]

- Q9)** a) Explain the process of Pultrusion in short. Discuss the effect of different process parameters on end properties of a Pultruded product. [8]
b) Explain with neat sketch filament winding process. State and explain effect of process parameter on quality of filament winding process. [8]

OR

- Q10)** a) Explain the process of vacuum bag molding. [8]
b) Explain the process of resin transfer molding. [8]

- Q11)** a) State the applications of FRP. [8]
b) What are nanocomposites? How are they prepared? Give its commercial applications. [8]

OR

- Q12)** a) Explain how FRP products are repaired. [8]
b) List the advantages and disadvantages of nanocomposites. List the different types of nanofillers. [8]



Total No. of Questions : 10]

P1278

SEAT No.:

[Total No. of Pages : 3

[4164]-234
B.E. (Polymer)
MOULD AND DIE DESIGN
(2003 Pattern) (Sem. - I)

Time : 4 Hours]

[Max. Marks : 100

Instructions to the candidates:

- 1) Answer any three questions from each section.
- 2) Answers to the two sections should be written in separate answer books.
- 3) Neat diagrams must be drawn wherever necessary.
- 4) Figures to the right indicate full marks.
- 5) Use of logarithmic tables slide rule, Mollier charts, electronic pocket calculator and steam tables is allowed.
- 6) Assume suitable data, if necessary.

SECTION - I

- Q1) a) Design and draw a 2 cavity 2 plate mold for the component shown in Fig.1 Draw at least 2 views with one sectional side view to bring out details of feed, ejection and cooling system. [35]

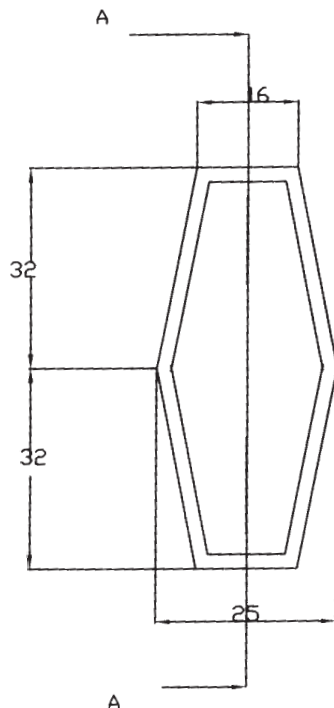

Sec A-A



All dimensions in mm

overall thk 2 mm

Matl: ABS
cavity pr. 200kg/cm²

Fig 1

P.T.O.

- b) Write down the bill of materials for the mold designed in Q. 1a. [5]

OR

- Q2)** a) Design and draw a 2 cavity 2 plate mold for component shown in Fig.2. Draw at least 2 views with one sectional view to bring out details of feed cooling and ejection system. [35]

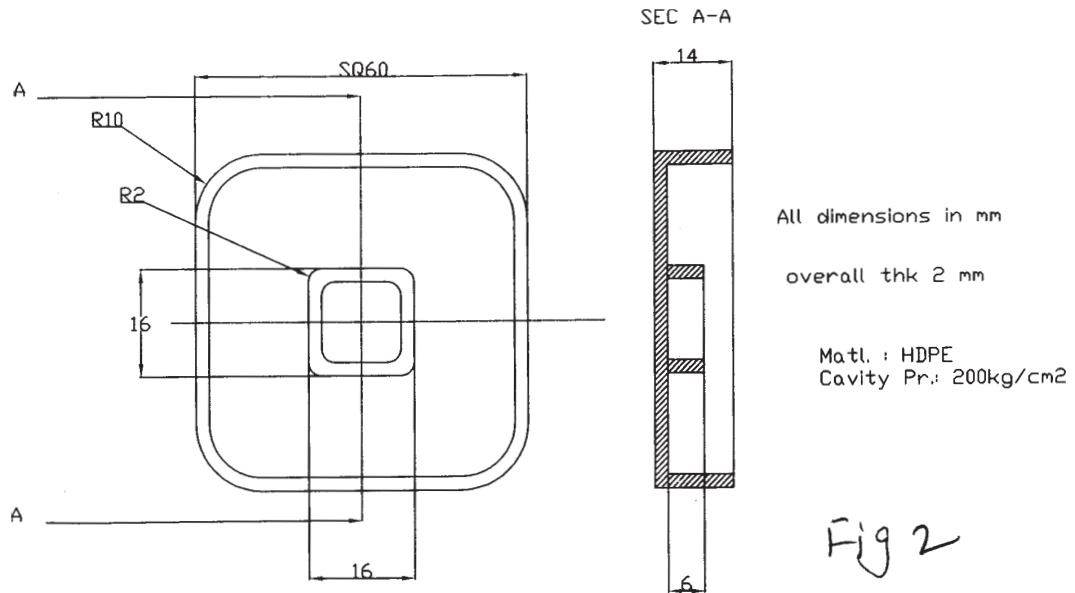

- b) Calculate the size of runner and gate used in mold designed in Q.2.a.[5]

- Q3)** List various methods for actuation of angled lifted splits. Explain any one in details. [10]

OR

- Q4)** List various split safety methods. Explain any one in details. [10]

SECTION - II

- Q5)** a) Write a process sheet for the core clamping plate and cavity clamping plate. Assume the drawing and details. [10]
b) Explain mold polishing operations. [6]

OR

- Q6)** a) Discuss mold maintenance practices. [8]
b) Explain the process of electrode EDM. [8]

- Q7)** a) List the various types of secondary nozzles used in hot runner molds. Explain any one. [10]
b) List merits and demerits of hot runner molds. [6]

OR

- Q8)** a) A manifold block of 250mm × 250mm × 50mm is to be heated by 4 cartridge heaters. If the loading value is 2W/cm³, calculate wattage of a single cartridge heater. [8]
- b) Explain with neat sketch (Any One): [8]
- Rectangular manifold block.
 - Manifold block cylindrical.

Q9) Draw a neat sketch and explain in short functions of the major parts of :

- Side fed blown film die.
- Centre fed blown film die. [18]

OR

- Q10)** a) Draw a neat proportionate sketch of in line pipe die and write in short about its major parts. [10]
- b) Write down stepwise procedure for design of a rod die. Mention the relevant design formulae. [8]

XXXX

Total No. of Questions : 12]

SEAT No.:

P1279

[Total No. of Pages : 2

[4164]-235
B.E. (Polymer Engineering)
POLYMER REACTION ENGINEERING
(2003 Pattern) (Elective - I) (Sem. - I)

Time : 3 Hours]

[Max. Marks : 100

Instructions to the candidates:

- 1) *Answers to the two sections should be written in separate books.*
- 2) *Draw neat diagrams wherever necessary.*
- 3) *Numbers to the right indicate full marks.*
- 4) *Assume suitable data, if necessary.*
- 5) *Use of logarithmic table, electronic pocket calculators is allowed.*

SECTION - I

- Q1)** a) Explain the role of residence time distribution and the concentration history in Polymerization reaction. **[8]**
b) Discuss the various parameters that affect the properties of any polymeric material. **[8]**

OR

- Q2)** a) Explain the importance of polymerization reaction engineering. **[8]**
b) Discuss the distinction between chain polymerization Vs Step Polymerization based on kinetics. **[8]**

- Q3)** a) Explain with the help of general polymerization reactions the general mechanism for the Free-Radical Polymerization. **[6]**
b) Derive the necessary design equation of Batch Reactor on Instantaneous Number Degree of Polymerization for carrying out Free-Radical Polymerization. **[12]**

OR

- Q4)** a) Discuss in detail Molecular weight distribution obtained via step growth polymerization. **[10]**
b) Derive the relationship giving average molecular weight of polymer obtained via chain polymerization. **[8]**

P.T.O.

Q5) Discuss the necessary equation for the steady state population balance equation for the particles having 'n' radicals in the Emulsion Polymerization. [16]

OR

Q6) Estimate a model for predicting rate of propagation in irreversible step growth polymerization at high conversion level where diffusion effect is predominates. [16]

SECTION - II

Q7) a) Describe in detail the synthesis of Polyvinylchloride via suspension polymerization technique. [9]
b) Discuss Liquid Flow Reactor and Recirculated Coil Reactor for the synthesis of Polystyrene. [9]

OR

Q8) Write a short note on reactor systems used for PET, Nylon 66 polymers. [18]

Q9) a) Discuss the MWD and reactor choice in polymerization process. [8]
b) Write a note on gel effect in step growth polymerization. [8]

OR

Q10) a) Discuss the conclusion from kinetics studies in free radical polymerization. [8]
b) Write a note on gel effect in chain growth polymerization. [8]

Q11) a) Write a short note on Reactor Selection for carrying out polymerization reaction. [8]
b) Explain with neat diagram the effect of different polymerization process variables on end-use properties. [8]

OR

Q12) a) Distinguish between batch and continuous polymerization process. [8]
b) Write a short note on Polymerization Techniques. [8]



Total No. of Questions : 12]

SEAT No.:

P1280

[Total No. of Pages : 4

[4164]-241
B.E. (Polymer)
INDUSTRIAL MANAGEMENT AND PROCESS ECONOMICS
(2003 Pattern) (Sem. - II)

Time : 3 Hours]

[Max. Marks : 100

Instructions to the candidates:

- 1) *Answers to section-I and section-II should be written on separate answer book.*
- 2) *Solve 3 questions from section-I and 3 questions from section-II.*
- 3) *Neat diagrams should be drawn whenever necessary.*
- 4) *Figures to right indicate full marks.*
- 5) *Assume suitable data, if necessary.*
- 6) *Use of electronic pocket calculator is allowed.*

SECTION - I

- Q1)** a) Enlist the limitations as well as uses of Breakeven Charts. [7]
b) Write a short note on Direct and Indirect Costs. [8]
c) Explain Marginal Cost. [3]

OR

- Q2)** a) Explain in detail various types of overheads. [7]
b) A limited company has sales of Rs.1,00,000. The variable cost was Rs.60,000 while the fixed cost was Rs.30,000. Find out the breakeven point and margin of safety. [6]
c) Define and explain the objectives of good plant layout. [5]

- Q3)** a) Explain the difference between Equity Shares and Preference Shares. [6]
b) What are the limitations of Capital Budgeting? [5]
c) Original cost of a machine is Rs.80,000 and its book value is Rs.50,000. Assuming the normal tax rate to be 50% and capital gain tax to be 40%, find out the net cash inflow if the machine can be sold for Rs.90,000. [5]

OR

- Q4)** a) A project needs an outlay of Rs.100,000 and earns the annual cash inflows of Rs.35000, Rs.40000, Rs.30000 and Rs.50000. Calculate the profitability index assuming the discount rate of 15%. [8]
b) What do you understand by Working Capital? Explain about its sources. [5]
c) Explain the concept Net Present Value. [3]

P.T.O.

- Q5)** a) Enlist and explain the main causes for depreciation. [8]
 b) The original investment for an asset was Rs.14,000 and the asset was assumed to have service life of 12 years with Rs.2,000 average value at the end of service life. After the asset has been in use for 5 years, the remaining service life and final salvage value are estimated of 10 years and Rs.1,000 resp. Under these conditions, what is the depreciation cost during sixth year of the total life if straight line depreciation method is used? [8]

OR

- Q6)** a) Write a short note on Joint Factor Rate method for Depreciation. [8]
 b) A company produces and sells 100 units per month at Rs.20 each. Marginal cost per unit is Rs.12 and fixed cost is Rs.300 per month. It is proposed to reduce price by 20%. Find the additional sales required to earn the same amount of profit as before. [8]

SECTION - II

- Q7)** a) Following table shows the machine time (in hours) for 5 jobs to be processed on two different machines. [9]

Job	1	2	3	4	5
Machine A	3	7	4	5	7
Machine B	6	2	7	3	4

Passing is not allowed. Find the optimal sequence in which jobs should be processed.

- b) Solve the following transportation problem : [9]

Suppliers → Consumers ↓	A	B	C	Available
I	6	8	4	14
II	4	9	8	12
III	1	2	6	5
Required	6	10	15	31

OR

- Q8)** a) Use the simplex technique to solve the following linear programming problem. [9]

$$\text{Maximize } Z = 3x_1 + 5x_2 + 4x_3$$

Subject to the constraints,

$$2x_1 + 3x_2 \leq 8$$

$$2x_2 + 5x_3 \leq 10$$

$$3x_1 + 2x_2 + 4x_3 \leq 15$$

$$x_1, x_2, x_3 \geq 0$$

- b) A firm plans to start production of 3-new products on its 3-plants. The unit cost of producing 'i' at plant 'j' is as given below. Find out the assignment that minimizes the total unit cost. [9]

Plant →		1	2	3
Product ↓				
1		10	8	12
2		18	6	14
3		6	4	2

- Q9)** a) A company manufactures guaranteed item-cricket bat. About 10% of the pieces are defective at present. The defective piece leaving factory costs 50 Paise to company to honour its guarantee. The company can conduct a test that always correctly identifies good as well as faulty pieces at the cost of 10 Paise per piece. Assuming all the defective pieces are returned, determine a decision tree as well as the optimal course of action and its expected cost. Also, at what test cost should the company be indifferent to testing? [8]
- b) Determine the optimal strategies for both the firms and the value of the game for the following payoff matrix for firm A. [8]

		Firm B				
		3	- 1	4	6	7
Firm A		- 1	8	2	4	12
		16	8	6	14	12
		1	11	- 4	2	1

OR

- Q10)** a) Under an employment promotion program, it is proposed to allow sale of newspaper on the buses during off-peak hours. The vendor can purchase the newspaper at special concessional rate of 25 Paise per copy against selling price of 40 Paise. Unsold copies are considered to be dead loss. How many copies the vendor should order so as to have maximum profit for which he has estimated following probability distribution for the number of copies demanded. [8]

No. of copies demanded	15	16	17	18	19	20
Probability	0.04	0.19	0.33	0.25	0.11	0.07

- b) A project schedule has the following characteristics. Construct the PERT network and find critical path and time duration of the project. [8]

Activity	Time	Activity	Time
(1 - 2)	2	4 - 8	8
(1 - 4)	2	5 - 6	4
(1 - 7)	1	6 - 9	3
(2 - 3)	4	7 - 8	3
(3 - 6)	1	8 - 9	5
(4 - 5)	5		

Q11) a) Perform ABC analysis on the following sample of items in an inventory given below : **[8]**

Item Name	Annual Consumption	Price per Unit (in Paise)
A	300	10
B	2800	15
C	30	10
D	1100	5
E	40	5
F	220	100
G	1500	5
H	800	5
I	600	15
J	80	10

b) The demand of an item is uniform at a rate of 25 units per month. The fixed cost is Rs.15 occurring for the each production run. The inventory cost is 30 Paise per month while the production cost is Rs.1 per item. Determine the size as well as frequency of production runs if the shortage cost is Rs.1.50 per item per month. **[8]**

OR

Q12) a) Write a short note on 'Always Better Control (ABC) Analysis. **[8]**

b) A manufacturing company uses Economic Order Quantity approach in planning the production of gears. Determine the economic lot size, number of production runs per year and total inventory costs using following available data - cost of each gear is Rs.250, annual demand of 60,000 gears, set-up Cost Rs.4,000 per set-up, the inventory carrying cost is established at 2% of average inventory value. The company works only for 300 days per year and the production rate is 400 gears per day. **[8]**



Total No. of Questions : 12]

SEAT No.:

P1281

[Total No. of Pages : 4

[4164]-244
B.E. (Polymer)
MECHANICS OF COMPOSITES
(2003 Pattern) (Elective - II) (Sem. - II)

Time : 3 Hours]

[Max. Marks : 100

Instructions to the candidates:

- 1) *Answer Q. No. 1 or 2, Q. No. 3 or 4 and Q. No. 5 or 6 from Section-I. Answer Q. No. 7 or 8, Q. No. 9 or 10 and Q. No. 11 or 12 from Section-II.*
- 2) *Answers to the two sections should be written in separate answer books.*
- 3) *Figures to the right indicate full marks.*
- 4) *Use of scientific calculator, log-log paper is allowed.*
- 5) *Assume suitable design data, if required.*

SECTION - I

- Q1)** a) Discuss polyester as a matrix used in fiber reinforced composites and state the effect of styrene content and effect of unsaturation level on the properties of polyester as a matrix material. [6]
- b) Write advantages and disadvantages of filament winding process. [6]
- c) Explain polar winding. [4]

OR

- Q2)** a) Discuss at least two variations of resin transfer moulding process. [6]
- b) Write advantages and disadvantages of pultrusion process. [6]
- c) Compare E glass and S glass fibers with reference to strength and applications. [4]

- Q3)** a) What is an transversely isotropic lamina? Write compliance matrix for it in terms of engineering constants. [4]
- b) Draw failure envelope for Tsai-Hill failure theory and write failure expression for each quadrant. [6]
- c) For an orthotropic lamina, prove that reduced transformed stiffness matrix is given by $[\bar{Q}] = [T]^{-1} [Q] [T]^T$
where $[Q]$ = Reduced stiffness matrix
 $[T]$ = transformation matrix. [8]

OR

P.T.O.

Q4) a) Give generalised statement of Tsai-Wn tensor failure theory and reduce it to plane stress condition. Give experimental procedure to determine second order as well as forth order strength tensors. [8]

b) Prove that apparent engineering constant for an orthotropic lamina stressed in non-principle x - y co-ordinate is given by

$$\frac{1}{E_x} = \frac{\cos^4 \theta}{E_1} + \left[\frac{1}{G_{12}} - \frac{2\nu_{12}}{E_1} \right] \sin^2 \theta \cos^2 \theta + \frac{\sin^4 \theta}{E_2}$$

$$\frac{1}{E_y} = \frac{\sin^4 \theta}{E_1} + \left[\frac{1}{G_{12}} - \frac{2\nu_{12}}{E_1} \right] \sin^2 \theta \cos^2 \theta + \frac{\cos^4 \theta}{E_2}$$

where E_1 , E_2 , G_{12} and ν_{12} are usual engineering constants in principle material directions. [8]

c) Define Chentsov coefficient, [2]

$$\mu_{ij,kl}$$

Q5) a) Obtain an expression for minimum volume fraction of fibers after which the strengthening effect of fibers is observed in composites. [6]

b) Give expressions for calculating E , G and ν (Poisson's ratio) in case of randomly oriented discontinuous fiber lamina. [4]

c) Give expressions for calculating following engineering constants in case of unidirectional discontinuous fiber 0° lamina. [6]

i) E_{11} .

ii) E_{22} .

iii) G_{12} .

iv) ν_{12}

OR

Q6) a) Derive an expression for obtaining major Poisson's ratio, ν_{12} for unidirectionally oriented fiber reinforced lamina. [7]

b) Derive an expression for transverse young's modulus, E_2 for unidirectionally oriented fiber reinforced lamina. [7]

c) State the lower bound on apparent young's modulus in terms of matrix and fiber modulus. [2]

SECTION - II

- Q7)** a) Give strain gauge rosette arrangement used in $\pm 45^\circ$ shear test. Explain test arrangement and explain how modulus can be measured. [8]
- b) Write short notes on : [8]
- i) Flexural Fatigue.
 - ii) Torsional Fatigue.

OR

- Q8)** a) Explain test procedure and limitations of torsion tube test for testing composite lamina. [5]
- b) How will you determine true tensile modulus from tensile testing of an off axis specimen. [6]
- c) Explain sandwich edgewise compression test. [5]
- Q9)** a) Discuss the type of laminate from the laminate codes given below with reasons. Explain which of the elements of [A], [B] and [D] matrix are zero. [12]
- i) $[\pm 45 / \pm 45]$.
 - ii) $[30 / -45 / -30 / 45]$.
 - iii) $[\pm \theta]$.
 - iv) $[0 / 90 / 0 / 90]$.
- b) Discuss anti-symmetric laminates. [6]

OR

- Q10)** a) Calculate [A], [B] and [D] for a $[0 / \pm 45]$ laminate from following data assuming each ply thickness to be 1mm.
- $E_{11} = 145 \text{ GPa}$ $E_{22} = 10.5 \text{ GPa}$
- $G_{12} = 7.5 \text{ GPa}$ $\nu_{12} = 0.28$
- Assume same matrix and reinforcement. [14]
- b) Write down force and moment resultants for a single layered an isotropic laminate. [4]

- Q11) a)** A steel beam with bending stiffness 30 kN-m^2 is to be replaced by a hybrid beam with 2 layers of E glass-epoxy and 3 layers of boron-epoxy. Fibers in the composite are parallel to the beam axis. Assuming both boron and E-glass plies are of 0.2mm thickness, determine the number of plies required for each fiber type. **[10]**

Given :

$$E_{\text{boron}} = 207 \text{ GPa}$$

$$E_{\text{glass}} = 39 \text{ GPa}$$

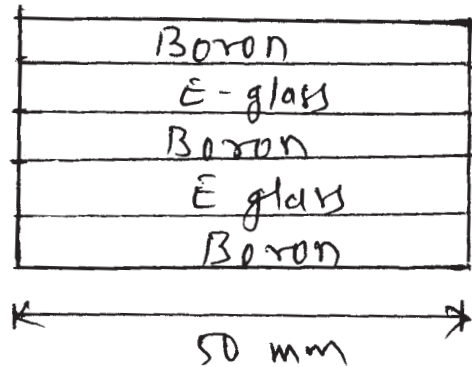

- b) Derive an expression for the buckling of a simply supported beam with a symmetric lay up. **[6]**

OR

- Q12) a)** Write short note on design procedure for designing a fiber reinforced pipe. **[6]**
- b) Write in detail about basic restrictions, assumptions made and consequences there of laminated plate theory. **[10]**



Total No. of Questions : 12]

SEAT No. :

P1282

[Total No. of Pages : 3

[4164]-256
B.E. (Computer Engineering)
ADVANCED DATABASES
(2003 Pattern) (Elective - I) (Sem. - I)

Time :3 Hours]

[Max. Marks :100

Instructions to the candidates:

- 1) *Answers to the two sections should be written in separate answer books.*
- 2) *Neat diagrams must be drawn wherever necessary.*
- 3) *Figures to the right indicate full marks.*
- 4) *Assume suitable data, if necessary.*

SECTION - I

- Q1)** a) Why some parallel database systems store an extra copy of each data item on disks attached to a different processor? Explain. [6]
- b) Explain any two partitioning techniques with respect to parallel database system. [10]

OR

- Q2)** a) Explain the following partitioning techniques. [10]
- i) Range.
 - ii) Round Robin.
- b) Explain pipelined parallelism in detail. [6]
- Q3)** a) Explain the following with respect to distributed databases. [12]
- i) Dead Lock Handling.
 - ii) Availability.
 - iii) Data transparency.
- b) What is Data Fragmentation? Explain. [6]

OR

- Q4)** a) Explain the following terms with respect to distributed databases. [12]
- i) Majority Protocol.
 - ii) Single Lock Manager.
 - iii) Based Protocol.
 - iv) Quorum Consensus.
- b) Explain any three system failure modes in distributed transaction mode.[6]

P.T.O.

- Q5)** a) Explain the different tiers in 3-tier architecture? [8]
b) Explain the following terms : [8]
i) SOAP.
ii) Xpath.

OR

- Q6)** a) What are cookies and how does a browser handle cookies? [6]
b) Explain with suitable example XML document. [10]

SECTION - II

- Q7)** a) Explain ETL process in Data Warehouse. [5]
b) One of the advantages of Data Warehouse is that we can use it to track how the contents of a relation change over time; in contrast, we have only the current snapshot of a relation in a regular DBMS. Discuss how you would maintain history of a relation R; taking into account that 'old' information must somehow be purged to make space for new information. [5]
c) Design snowflake and starflake Schemas for sales product system. [7]

OR

- Q8)** a) Describe Kimball's nine steps for Data Warehouse design. [7]
b) Write short notes on : [10]
i) OLAP cube.
ii) Data cleaning.

- Q9)** a) Explain the splitting criteria and pruning process. For decision tree construction with suitable example. [7]
b) Write short notes on : [10]
i) Outlier analysis.
ii) Text Mining.

OR

- Q10)** a) Explain preprocessing step in data mining. [7]
b) Describe different types of clustering techniques with suitable example. [5]
c) Write short note on Bayesian classifier. [5]

- Q11)** a) Explain any two techniques that support the evaluation of Boolean and Ranked queries. [8]
- b) Explain the relevance ranking in information retrieval system. [8]

OR

- Q12)** a) Define Information Retrieval System. How it is differ from database system. [8]
- b) Explain the different approaches used for indexing of documents. [8]

* * *

Total No. of Questions : 12]

SEAT No.:

P1283

[Total No. of Pages : 2

[4164]-257
B.E. (Computer Engg.)
ARTIFICIAL INTELLIGENCE
(2003 Pattern) (Sem. - I) (Elective - I)

Time : 3 Hours]

[Max. Marks : 100

Instructions to the candidates:

- 1) *Attempt three questions from section-I and three questions from section-II.*
- 2) *Answers to the two sections should be written in separate books.*
- 3) *Neat diagrams must be drawn wherever necessary.*
- 4) *Assume suitable data, if necessary.*

SECTION - I

- Q1)** a) What are intelligent agents? Explain the architecture of any agent with an example. [8]
b) What are the various applications of AI? [8]

OR

- Q2)** a) Explain forward and backward reasoning with an example. [8]
b) Explain production system and what are the characteristics of a good search strategy? [8]
- Q3)** a) Define Heuristics. Explain the A* algorithm with an example. [10]
b) Apply constraint satisfaction method to solve the following crypt arithmetic problem : [8]

SEND + MORE = MONEY

OR

- Q4)** a) Explain Hill Climbing algorithm. Explain plateau, ridge, local maxima and global maxima. [8]
b) Explain alpha beta cut off for an example and state its advantages. [10]
- Q5)** a) Explain the Unification Algorithm. [8]
b) Write a script of going to a Restaurant. [8]

OR

P.T.O.

- Q6)** a) Explain semantic networks and frames. [8]
b) Represent the following sentences in conceptual dependency : [8]
i) John Ran.
ii) John gave Marry the AI book.
iii) John ate ice cream with a spoon.
iv) John pushed the door.

SECTION - II

- Q7)** a) What are the different components of a planning system? [8]
b) What is Non-Linear Planning? Explain the steps in Non-Linear Planning with an example. [10]

OR

- Q8)** a) Explain how Waltz's algorithm can be used for labeling trihedral figures. [8]
b) Explain Goal Stack Planning with a suitable example. [10]

- Q9)** a) What is NLP? Explain in brief the various steps in natural language processing. [8]
b) Explain RTN with an example. [8]

OR

- Q10)** a) Explain the Robot architecture. [8]
b) Explain how ATN can be used to understand natural language sentence. [8]

- Q11)** a) Give detailed architecture of Expert System and explain its components. [8]
b) Explain in detail artificial neural network architecture and its components. [8]

OR

- Q12)** a) Give any two applications of neural network. [8]
b) Comment on why Prolog is used to design Expert Systems. [8]



Total No. of Questions : 12]

SEAT No.:

P1284

[Total No. of Pages : 2

[4164]-259
B.E. (Computer Engg.)
NETWORKS AND INFORMATION SECURITY
(2003 Pattern) (Sem. - II)

Time : 3 Hours]

[Max. Marks : 100

Instructions to the candidates:

- 1) *Answer any three questions from each section.*
- 2) *Answers to the two sections should be written in separate books.*
- 3) *Neat diagrams must be drawn wherever necessary.*
- 4) *Assume suitable data, if necessary.*

SECTION - I

- Q1)** a) What are attacks in Computer Network? Enlist and explain different types of active attacks. [10]
b) Describe general model for N/W security with suitable diagram. [8]

OR

- Q2)** a) What is brute force attack? Explain it with suitable example. Enlist other attack on encrypted messages. [10]
b) Differentiate worms, viruses and Trojans with suitable examples. [8]
- Q3)** a) Explain Euler's totient function with suitable example which is used in public key cryptography. [8]
b) In a public key system using RSA, you intercept the ciphertext $c = 10$ sent user whose public key is $e = 5$ and $n = 35$. What is plain text m ? [8]

OR

- Q4)** a) Explain Diffie-Hellman algorithm. What is man in middle attack in DH-algorithm? [8]
b) How internal and external error control is done by using message authentication? Discuss each control with suitable diagram. [8]
- Q5)** a) How keys are generated in DES algorithm? Discuss it in detail. [8]
b) Explain triple DES algorithm with suitable example. [8]

OR

P.T.O.

- Q6)** a) How many parameters are considered to design the AES algorithm? Enlist and discuss each in detail. [8]
b) What is public announcement and public available directory techniques for key distribution? Explain each with suitable diagram and example. [8]

SECTION - II

- Q7)** a) What is tunneling? Discuss any two tunneling protocols in detail. [10]
b) What is Authentication Header? How it is used in authentication and integrity checking. [8]

OR

- Q8)** a) What is VPN? What are the needs of VPN? Discuss each in brief? [8]
b) Enlist and discuss types of pay loads of ISAKMP. What is the purpose of each. [10]

- Q9)** a) What are characteristics of firewall? [8]
b) Define packet filtering router. What informations are used in packet filtering? [8]

OR

- Q10)** a) What IDS and IPS? Differentiate IDS and IPS. [8]
b) Define WEP. How do WEP works? Give the benefits of WEP. [8]

- Q11)** a) Discuss SSL protocol stack with suitable diagram. [8]
b) What is SET? Give and explain key features of SET in detail. [8]

OR

Q12) Write short notes on following : [4 × 4 = 16]

- a) Kerberos.
- b) S/MIME.
- c) PGP.
- d) E-Cache.



Total No. of Questions : 12]

SEAT No.:

P1285

[Total No. of Pages : 3

[4164]-263
B.E. (Computer/IT)
SOFTWARE ARCHITECTURE
(2003 Pattern) (Elective - II) (Sem. - II)

Time : 3 Hours]

[Max. Marks : 100

Instructions to the candidates:

- 1) *Figures to the right indicate full marks.*
- 2) *Answers to the two sections should be written in separate answer books.*
- 3) *From Section-I, Answer (Q 1 OR Q 2) and (Q 3 OR Q 4) and (Q 5 OR Q 6).*
- 4) *From Section-II, Answer (Q 7 OR Q 8) and (Q 9 OR Q 10) and (Q 11 OR Q 12).*
- 5) *Make suitable assumptions wherever relevant and appropriate.*

SECTION - I

- Q1)** a) What do you mean by robust software architecture? **[4]**
b) Software architecture is often compared with building architecture. What are the strengths and weaknesses of this comparison? **[8]**
c) “Object Inheritance is white box reuse”. Justify. **[6]**

OR

- Q2)** a) What documentation would you need to do performance analysis of an architecture? **[4]**
b) Explain with suitable example : **[8]**
i) Architecture is high-level design.
ii) Architecture is the overall structure of the system.
iii) Behavior of each software element is part of the architecture.
iv) Architecture has components and connectors.
c) Explain : Architecture is the vehicle for stakeholder communication. **[6]**

- Q3)** Explain and illustrate the following concepts (in context of quality attributes) with examples : **[16]**
a) Following concern in context of modifiability : “When is a change made and who makes it”.
b) Any one quality attribute scenario for performance.

P.T.O.

- c) Measuring and specifying performance for a web site.
- d) Usability aspects observed by you in a typical MS WINDOWS desktop software. (Hint : MS WORD/IE7).

OR

- Q4)** a) Draw a neat diagram to depict “Availability” general scenario. How does one measure availability (formula). Write in brief the tactic “Transaction” as a fault prevention tactic. [8]
- b) In brief write about tactics. [8]
- i) Defer binding time.
 - ii) Checkpoint rollback.
- Q5)** a) What is the difference between Abstract Factory pattern and Factory pattern? Explain with suitable example. [8]
- b) Give the structure diagram for FACADE pattern. Explain the structure with example. [8]

OR

- Q6)** a) What can a Mediator pattern do for us, illustrate with an example. [4]
- b) Which design pattern will you choose to “Ensure a single instance of a class in memory for the application, “How can one achieve/implement this in C++.” [6]
- c) Write short note on Design Pattern “PROXY”. [6]

SECTION - II

- Q7)** a) What is JDBC? What are stored procedures? What are the steps required to execute a query in JDBC? What is cold backup, hot backup, warm backup recovery? [8]
- b) Write short note on : [8]
- i) JAVA on client side.
 - ii) JXTA.

OR

- Q8)** a) Why is Java said to be platform independent and portable, explain. [6]
- b) In context of EJB what do you understand by [6]
- i) Session beans.
 - ii) Message beans.
- c) In context of Java what do you understand by the terms RMI registry, remote object and serialisability. [4]

- Q9)** a) What kind of responsibilities does a Server side have in a web application? [4]
b) Explain following web concepts through simple examples. [12]
i) DOM tree.
ii) Authentication.
iii) http.
iv) Load balancing.

OR

- Q10)** a) What kind of responsibilities does a web client have? How can one make web client more dynamic. [4]
b) Explain with example : [12]
i) CGI.
ii) Application Server.
iii) Legacy Application.
iv) Web Server.

- Q11)** a) What are the life cycle methods of Applet? Explain them? [4]
b) Write short note (Any Two) : [8]
i) DLL services.
ii) COM/DCOM.
iii) Distributed Object.
c) Discuss concept : [6]
i) Windows Registry.
ii) Query Interface.

OR

- Q12)** a) Compare .NET and J2EE. [6]
b) Write short note on Distributed Objects. [6]
c) Write briefly about : common language runtime and C#, two of the features of .NET platform. [6]

XXXX

Total No. of Questions : 12]

SEAT No.:

P1286

[Total No. of Pages : 2

[4164]-265
B.E. (Computer)
HIGH PERFORMANCE NETWORKS
(2003 Pattern) (Elective - II) (Sem. - II)

Time : 3 Hours]

[Max. Marks : 100

Instructions to the candidates:

- 1) *Solve Q. 1 or Q. 2, Q. 3 or Q. 4, Q. 5 or Q. 6 from section-I and solve Q. 7 or Q. 8, Q. 9 or Q. 10, Q. 11 or Q. 12 from section-II.*
- 2) *Answer any three questions from each section.*
- 3) *Answers to the two sections should be written in separate books.*
- 4) *Neat diagrams must be drawn wherever necessary.*
- 5) *Figures to the right indicate full marks.*
- 6) *Assume suitable data, if necessary.*

SECTION - I

- Q1)** a) Describe the significance of Carrier Extension in Gigabit Ethernet MAC Operation. [8]
b) Differentiate Ethernet, Fast Ethernet and Gigabit Ethernet based on MAC characteristics. [8]

OR

- Q2)** a) Differentiate between Gigabit Ethernet and ATM as LAN Technology choices (at least 6 points). [8]
b) Discuss in short about 1000 BASE - X Family with suitable applications. [8]

- Q3)** a) Define the terms CIR, Bc, Be. What are their significance in congestion control? [6]
b) An organization has decided to provide Internet Facility through ISDN to all its users. Draw and explain the topology of this network including appropriate required components to fulfil this requirement. [6]
c) Define the terms FECN, BECN and DLCI along with their significance. [6]

OR

- Q4)** a) Comment on the Frame relay Congestion Control. [6]
b) Draw and explain the LAPD Frame structure. What is the significance of SAPI and TEI fields? [6]
c) Differentiate between Frame relay and ATM. [6]

P.T.O.

- Q5)** a) Explain the need of ATM Adaptation layer. Describe in short the AAL Type 5 along with its suitable application. [8]
b) Comment on B-ISDN user network Interface? What type of Services can be offered by B-ISDN? [8]

OR

- Q6)** a) Draw and explain cell Delineation State Diagram. [8]
b) Comment on the various ATM service categories. The classification is based on which attributes. [8]

SECTION - II

- Q7)** a) List and explain various xDSL types (At least 4 points). [8]
b) Explain the operation of ADSL using DMT (Discrete Multitone). [8]

OR

- Q8)** a) Draw and explain a typical ADSL equipment configuration. [8]
b) What is a POTS Splitter? [4]
c) Comment on DSLAM (Digital Subscriber Line Access Multiplexer). [4]

- Q9)** a) Explain the significance and working of RSVP. [8]
b) Explain the working of MPLS with suitable diagram. [8]

OR

- Q10)** a) What is the role of LDP in MPLS? Also explain the various LDP message Exchanges. [8]
b) Describe in short expedited forwarding and assured forwarding concepts. [8]

- Q11)** a) Comment on the various aspects of 802.11a standard including frequency band, data rate supported etc. [6]
b) Differentiate between 802.11a and 802.11g standards. [6]
c) Explain the various steps required to setup and configure Infrastructure Wireless Network. [6]

OR

- Q12)** a) Differentiate between 802.16 and 802.11 standards. [6]
b) Explain the following terms : [6]
1> Time Division Duplexing (TDD).
2> Frequency Division Duplexing (FDD).
c) Draw and explain 802.16 protocol stack. [6]

☒☒☒☒

Total No. of Questions : 12]

SEAT No.:

P1287

[Total No. of Pages : 3

[4164]-272
B.E. (Information Technology)
ADVANCED DATABASE MANAGEMENT
(2003 Pattern) (Sem. - I)

Time : 3 Hours]

[Max. Marks : 100

Instructions to the candidates:

- 1) *Answers to the two section should be written in separate books.*
- 2) *Neat diagrams must be drawn wherever necessary.*
- 3) *Assume suitable data, if necessary.*
- 4) *Section-I : Q. 1 or Q. 2, Q. 3 or Q. 4, Q. 5 or Q. 6.*
- 5) *Section-II : Q. 7 or Q. 8, Q. 9 or Q. 10, Q. 11 or Q. 12.*

SECTION - I

- Q1)** a) Explain different types of skew in parallel databases. Describe any two methods to handle skew. [5]
b) Explain Parallel Join Algorithms. [6]
c) Explain speed-up and scale-up with suitable example. [6]

OR

- Q2)** a) Explain Parallel Database Architectural Models. [5]
b) Describe Implementation issues in Parallel query evaluation. [6]
c) Describe parallel database system design issues with suitable database application. [6]

- Q3)** a) State different types of failures in distributed systems and explain failure handling in distributed database using 2Phase Commit protocol and 3 Phase Commit protocol. [7]
b) Write a short note on Bully Algorithm. [5]
c) Explain types of fragmentation in distributed databases. State advantages of fragmentation. [5]

OR

- Q4)** a) Explain different possible query processing strategies in distributed databases. [7]
b) Describe centralized approach to handle deadlock in distributed databases. [5]
c) Explain distributed locking protocol and majority based protocol for Distributed Concurrency Control. [5]

P.T.O.

- Q5)** a) Describe XML query algebra operation. Describe the use of XQuery for Path Expression and FLWR expression in web-DBMS. [8]
b) Write a short note on : [8]
i) URL and HTTP.
ii) DTD.

OR

- Q6)** a) Describe the various FACETS used in XML validation with suitable examples. [8]
b) Write a short note on : [8]
i) Web services and SOAP.
ii) XML Schemas.

SECTION - II

- Q7)** a) Explain ETL process in data warehouse. [6]
b) State advantages and disadvantages of star, snowflake and starflake schemas. [6]
c) Discuss the importance of managing meta data and how this relates to the integration of the data warehouse. [5]

OR

- Q8)** a) Identify the major issues associated with designing a data warehouse and explain in brief. [6]
b) Explain any two preprocessing techniques in data warehouse. [6]
c) Discuss how OLTP differ from data warehousing? [5]

- Q9)** a) Define classification. Explain decision tree classification approach in data mining with suitable example. [9]
b) Define clustering. Explain different types of clustering in data mining with suitable example. [8]

OR

- Q10)** a) Explain Apriori Algorithm with suitable example. [9]
b) Write a short note on : [8]
i) Outlier Analysis.
ii) Navie Bayes.

- Q11)** a) Define Information Retrieval System. Describe Vector Space Model. [6]
b) Write short notes on : [10]
i) Signature File.
ii) Web crawler.

OR

- Q12)** a) Explain any two techniques that support the evaluation of Boolean and Ranked queries. [6]
- b) Explain different factors for relevance ranking in information retrieval system. [5]
- c) Describe distinct ways a user can find information on the web. [5]



Total No. of Questions : 11]

SEAT No.:

P1288

[Total No. of Pages : 2

[4164]-273

B.E. (IT)

SOFTWARE TESTING AND QUALITY ASSURANCE

(2003 Pattern) (Sem. - I)

Time : 3 Hours]

[Max. Marks : 100

Instructions to the candidates:

- 1) *Answer question number 1 or 2, 3 or 4, 5 or 6 from section-I.*
- 2) *Answer question number 7 or 8, 9 or 10, 11 from section-II.*
- 3) *Answers to the two sections should be written in separate answer books.*
- 4) *Neat diagrams must be drawn wherever necessary.*
- 5) *Figures to the right indicate full marks.*
- 6) *Assume suitable data, if necessary.*

SECTION - I

- Q1)** a) What are different levels of testing? Which software components are most suitable for unit testing and why? [8]
- b) Explain in short any four methods of System Level Testing. [8]

OR

- Q2)** a) What type of skills do you believe should be required of a person being hired as a test specialist? [8]
- b) Differentiate between white box testing and black box testing. [8]

- Q3)** a) Explain unit test planning in detail. [8]
- b) Explain in detail different functions (responsibilities) to be handled in a testing life cycle or process. [8]

OR

- Q4)** a) Describe software defect life cycle. [8]
- b) Explain what is test case database, defect repository and configuration management repository in context of test infrastructure management. [8]

- Q5)** a) Write a note on Control Flow structures. Also focus on sequencing and nesting of flow graphs. [8]
- b) Explain with examples following in-process quality metrics. [10]
- i) Defect arrival pattern during machine testing.
 - ii) Defect removal effectiveness.

P.T.O.

OR

- Q6)** a) Explain the importance of the metric - *percentage delinquent fixes* in context with software maintenance. Also calculate percent delinquent fixes (pdf) if number of fixes delivered in a specified time are 40 and the number of fixes that exceeded the response time criteria by severity level are 80. [10]
- b) Explain GQM technique in detail. Draw a GQM tree for the quality goal of achieving better software usability. [8]

SECTION - II

- Q7)** a) What is meant by software quality control? Explain the method of measuring software reliability as a software quality attribute. [8]
- b) Enumerate Ishikawa's seven basic quality tools. Explain any two in detail. [8]

OR

- Q8)** a) Illustrate with examples the use of following techniques in improving quality : [8]
- i) Code inspection.
- ii) Project Planning.
- b) What are the different components of costs for quality software? Explain in detail. [8]
- Q9)** a) Explain the role of effective software configuration management in software quality. [8]
- b) Draw a neatly labeled cleanroom process. Explain how step wise refinement process helps in improving the quality. [8]

OR

- Q10)** a) How does the ISO 9000:9001 standard ensure in producing a good quality software? [8]
- b) How is defect prevention and process change management brought into practice? [8]

- Q11)** Write short notes on Any Three : [18]
- a) Importance of code review in software security testing.
- b) Functional testing of Web-site.
- c) Client-Server Testing techniques.
- d) Class testing.



Total No. of Questions : 10]

SEAT No.:

P1289

[Total No. of Pages : 2

[4164]-277

B.E. (IT)

**ORGANISATIONAL BEHAVIOUR AND MANAGEMENT CONCEPTS
(2003 Pattern) (Sem. - I) (Elective - I)**

Time : 3 Hours]

[Max. Marks : 100

Instructions to the candidates:

- 1) *Q. 5 and Q. 10 are compulsory.*
- 2) *Solve any two from remaining each section.*
- 3) *Both the sections should be written in a separate answer books.*

SECTION - I

- Q1)** Define the term organisational behaviour. Elaborate any two models, in detail. **[16]**
- Q2)** Critically evaluation the different types of groups with its advantages. **[16]**
- Q3)** “Conflict management skills are key to organisational success”. Discuss. **[16]**
- Q4)** Compare and contrast Maslow’s theory of hierarchy needs, with suitable examples. **[16]**
- Q5)** Write short notes on (Any Three) : **[18]**
- a) *Morale Indicators.*
 - b) *Organisational Culture.*
 - c) *Concepts of OB.*
 - d) *Theory X and Theory Y.*
 - e) *Perception.*

SECTION - II

- Q6)** Which strategies would you recommend to reduce resistance to change in an organisational setting? **[16]**
- Q7)** Critically analyse the role of the managerial grid in the leadership literature. **[16]**
- Q8)** Discuss down-sizing as one of the essential tasks of modern managers. **[16]**

P.T.O.

Q9) Define stress management. What are the causes of stress? Give suitable examples. **[16]**

Q10) Write short notes on (Any Three) : **[18]**

- a) Re-engineering.
- b) Characteristics of a leader.
- c) Defence mechanism.
- d) Organisational Effectiveness.
- e) Ill-effects of Stress.



Total No. of Questions : 12]

SEAT No.:

P1290

[Total No. of Pages : 2

[4164]-279
B.E. (Information Technology)
DISTRIBUTED SYSTEMS
(2003 Pattern) (Sem. - II)

Time : 3 Hours]

[Max. Marks : 100

Instructions to the candidates:

- 1) *Answer Question 1 or 2, 3 or 4, and 5 or 6 from section-I and Question 7 or 8, 9 or 10, and 11 or 12 from section-II.*
- 2) *Answers to the two sections should be written in separate answer sheet.*
- 3) *Neat diagrams must be drawn wherever necessary.*
- 4) *Figures to the right indicate full marks.*
- 5) *Assume suitable data, if necessary.*

SECTION - I

- Q1)** a) Describe fundamental of Models of distributed systems. **[8]**
b) Give five types of hardware resource and five types of data or software resource that can be usefully shared. Give examples of their sharing as it occurs in distributed systems. **[8]**

OR

- Q2)** a) What is marshaling? What are the different approaches of external data representation? **[8]**
b) List and explain advantages and disadvantages of distributed systems over centralized system and personal computers. **[8]**

- Q3)** a) What is RMI? Explain types of RMI invocation semantics. **[8]**
b) What is Call Back RPC? How does a server handle Call Back to the client? **[8]**

OR

- Q4)** a) What is group communication? Explain different types of group communication. **[8]**
b) How does RPC Exchange Protocol work in client server communication? **[8]**

P.T.O.

- Q5)** a) Draw and explain simple auto-mounting for NFS? [10]
b) Discuss desirable features of good distributed file system. List the functions of distributed file system. [8]

OR

- Q6)** a) What is file sharing? Explain different types of file sharing semantics. [10]
b) With respect to CODA file system explain caching and replication. [8]

SECTION - II

- Q7)** a) What is a distributed Deadlock? What are the necessary conditions for deadlock to occur in distributed environment? [8]
b) Enumerate the various issues in clock synchronization. [8]

OR

- Q8)** a) Discuss vector clock algorithm. [8]
b) List and explain uses of election algorithm? What is Bully algorithm? [8]

- Q9)** a) What is message ordering? Explain FIFO order and causally ordered multicast. [8]
b) What is check pointing? Explain independent check pointing and coordinated check pointing. [8]

OR

- Q10)** a) What is Fault tolerance? Explain different types of failures. [8]
b) Explain Byzantine general problems. [8]

- Q11)** a) Explain in brief the steps to build CORBA application. [10]
b) Discuss following : [8]
i) OBV,
ii) CCM,
iii) GIOP,
iv) DDS.

OR

- Q12)** a) What is Cluster? Explain different types of clusters with example. [10]
b) Draw and explain CORBA ORB architecture. [8]



Total No. of Questions : 11]

SEAT No. :

P1489

[Total No. of Pages : 2

[4164]-282

B.E. (Biotechnology)

ENZYME & FERMENTATION ENGINEERING

(2003 Pattern) (Sem. - I)

Time :3 Hours]

[Max. Marks :100

Instructions to the candidates:

- 1) Answer three questions from Section - I and three questions from Section - II.
- 2) Answers to the two sections should be written in separate answer books.
- 3) Neat diagrams should be drawn wherever necessary.
- 4) Figures to the right indicate full marks.

SECTION - I

- Q1)** a) Explain the mechanisms of catalysis of enzyme acting on two substrates. How are the kinetics determined in these cases? [8]
- b) What is dilution rate? Discuss the effect of dilution rate on biomass and substrate concentration. [8]

OR

- Q2)** a) An inhibitor (I) is added to the enzymatic reaction at a level of 1 gram/lit. The following data was obtained for $K_m = 9.2$ gram S/lit. Is the inhibitor competitive or non-competitive? [8]

V g/l-min	0.909	0.658	0.493	0.4	0.33	0.289	0.227
S g/l	20	10	6.67	5	4	3.33	2.5

- b) How does the kinetics of enzyme change if it is acting in a heterogeneous system? Elaborate. [8]
- Q3)** a) Explain the fed batch mode of fermenter operation in detail. [8]
- b) What is solid state fermentation? Enlist its salient features and also advantages and disadvantages. [8]

OR

- Q4)** Discuss in detail the various types of bioreactors used for submerged liquid fermentation. [16]

P.T.O.

- Q5)** a) How does sparger design affect the fermentation process? Explain the different types of spargers in brief. [9]
b) What are the different factors which affect oxygen transfer in fermenter? [9]

OR

- Q6)** a) Classify the fermentation broths based on rheology giving example of each type. [8]
b) Explain the procedure for calculating power consumed by an agitator considering different flow regimes. [10]

SECTION - II

- Q7)** a) Write a note on thermal death kinetics of microorganisms. [8]
b) Explain the different configurations used for continuous steam sterilization along with their temperature-time profiles. [8]

OR

- Q8)** Write notes on : [16]
a) Inoculum development for scale up.
b) Process parameters for scale up.

- Q9)** a) What is microencapsulation of enzymes and how is it done? [8]
b) What is effectiveness factor and its significance in immobilized enzyme kinetics? [8]

OR

- Q10)** a) Derive the expression for predicting kinetics for enzyme immobilized on internal surface of a support. [8]
b) Explain the medical applications of immobilized enzymes. [8]

- Q11)** Write short notes on (any three) : [18]
a) Advantages of semisynthetic process.
b) Microfermentation.
c) Animal cell reactor technology.
d) Hollow fibre bioreactor.
e) Applications of disposable fermenters.

* * *

Total No. of Questions : 12]

SEAT No. :

P1520

[Total No. of Pages : 3

[4164] - 70

B.E. Prod. (Production Sandwich)

DIE AND MOULD DESIGN

(Sem. - I) (2003 Pattern) (Elective - I)

Time :3 Hours]

[Max. Marks :100

Instructions to the candidates:-

- 1) *From Section I Solve Q.1 or Q.2, Q.3 or Q.4, Q.5 or Q.6 and from Section II Solve Q.7 or Q.8, Q.9 or Q.10, Q.11 or Q.12.*
- 2) *Answers to the two sections should be written in separate answer books.*
- 3) *Neat diagrams must be drawn wherever necessary.*
- 4) *Figures to the right indicate full marks.*
- 5) *Use of electronic pocket calculator is allowed.*
- 6) *Assume suitable data, if necessary.*

SECTION - I

Unit - I

- Q1)** a) Explain with neat sketch the rolling mills used for first break down of ingot into bloom and slab. [6]
b) Explain the difference between forward and backward extrusion. [6]
c) Explain with neat sketch the different zone of wire draw die. [4]

OR

- Q2)** Write short note on any three. [16]
a) Defects in rolling.
b) CCD and Shape factor.
c) Stock preparation in wire drawing.
d) Von Mises criterion.

Unit - II

- Q3)** a) Explain the principal of metal cutting and effect of clearance in press working. [8]
b) What is compound die explain with suitable example. [8]

OR

- Q4)** a) What is OBI? Explain its advantages, limitations and application. [8]
b) How presses are classified on the basis of actuation of slide explain with neat sketch? [8]

P.T.O.

Unit - III

Q5) Design simple die for the component shown in fig. 1

[18]

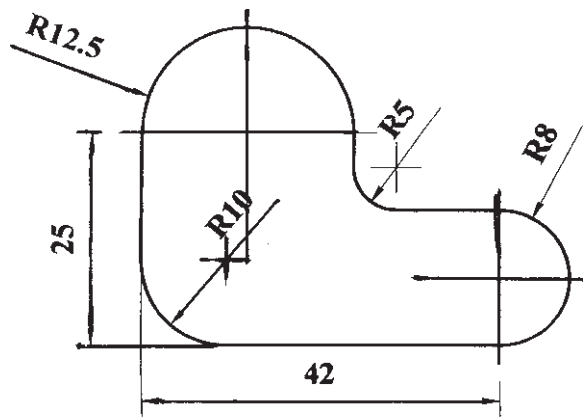

Fig. 1: Structural steel 1.4mm thick

OR

Q6) Progressive die desing.

- Draw assembly drawing with locating element of a progressive die for the component shown in fig 2. [8]
- Draw strip layout and find out material utilization. [5]
- Find out cutting force at each station and press tonnage with staggering and full shear. [5]

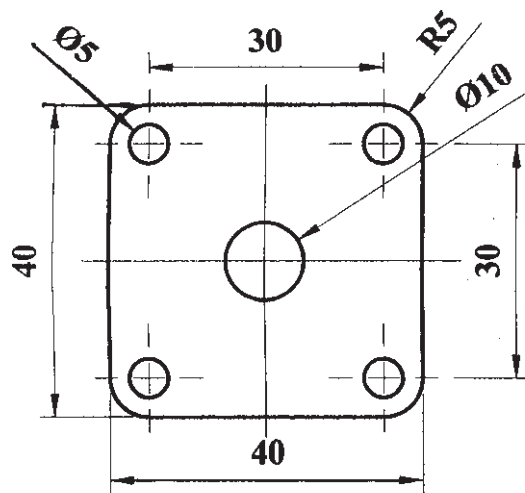

Fig. 2: Structural steel 1mm thick

SECTION - II

Unit - IV

- Q7) a) Explain the working of board drop hammer and give its advantages and disadvantages. [8]
- b) What are the differences between open die and close die forging? [8]

OR

- Q8)** Write short note on any three. [16]
- PM forging.
 - Rotary swaging.
 - Forging defects.
 - Forgability.

Unit - V

- Q9)** a) How injection moulding machines are specified? [8]
 b) What are the two types of plastics give differences. [8]

OR

- Q10)** Explain with limitations and applications following processes. [16]
- Compression moulding.
 - Blow moulding.
 - Injection moulding.

Unit - VI

- Q11)** Design a single impression injection mould to produce **any one** of the component shown in fig. 7a and fig. 7b. The component is to be manufacture in high impact polystyrene. The drawing should include a plan view of the moving half and side sectional view of both halves. Following point should be considered while designing. [18]

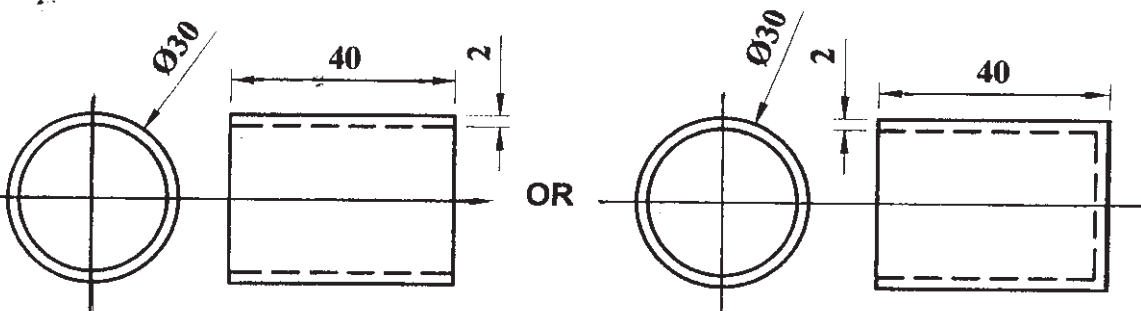

Fig. 7a

Fig. 7b

OR

- Q12)** a) Explain injection mould for thermo set. [6]
 b) Explain various types of gates used in injection mould. [6]
 c) Explain cooling systems in injection mould. [6]



Total No. of Questions : 12]

SEAT No. :

P1521

[Total No. of Pages : 4

[4164] - 92

B.E. (Electrical)

DIGITAL CONTROL SYSTEMS

(2003 Pattern) (Sem. - II)

Time :3 Hours]

[Max. Marks :100

Instructions to the candidates:

- 1) *Answer any one question from each pair of questions Q1 & Q2, Q3 & Q4, Q5 & Q6, Q7 & Q8, Q9 & Q10, Q11 & Q12.*
- 2) *Answer to the two sections should be written in separate answer books.*
- 3) *Neat diagrams must be drawn wherever necessary.*
- 4) *Figures to the right indicate full marks.*
- 5) *Use of electronic unprogrammable pocket calculator is allowed.*
- 6) *Assume suitable data, if necessary.*

SECTION - I

- Q1)** a) Draw basic digital control scheme in block diagram form & explain the function of each block. [8]
- b) A discrete system is given as: [8]
 $y(n) = x(-n + 2)$ check whether the system is
- i) Static or Dynamic
 - ii) Linear or Non linear
 - iii) Shift Invariant or variant
 - iv) Causal or Non causal.

OR

- Q2)** a) State and explain sampling theorem. Also describe the reconstruction process. [8]
- b) For a given sequence $x(n) = \{5, -4, \frac{2}{3}, -3, 2\}$ [8]
- i) Delay the sequence by 2 samples.
 - ii) Compress the sequence by time scale 2.
 - iii) Attenuate the sequence by amplitude scale 2.
 - iv) Fold and advance the sequence by one sample.
- Q3)** a) Discuss the various methods of obtaining the convolution of discrete time system. [8]
- b) Draw a neat sketch of digital temperature control and explain its working. [8]

P.T.O.

OR

- Q4) a)** Explain with neat diagrams the Direct form - I and Direct form - II representations of discrete time system. [8]
- b)** Obtain linear convolution of following sequences by multiplication method & then verify the result by Tabulation method. [8]
- $$x(n) = \{1, 4, 2, 1\}; h(n) = \{2, 1, -2, 1\}$$

- Q5) a)** State & prove important properties of Z-transform. [6]
- b)** Find the Z-transform of the sequence: [12]
- i) $X(t) = \sin wt$ ii) $X(s) = \frac{1}{s(s+1)}$

OR

- Q6) a)** Explain any two methods of obtaining Inverse Z-transform. [6]
- b)** Evaluate the inverse Z-transform of: [12]

- i) $X(z) = \frac{1 - \frac{1}{2}z^{-1}}{1 - \frac{1}{4}z^{-2}}; |z| > \frac{1}{2}$ by Partial Fraction.
- ii) $X(z) = \frac{1}{(z-1)(z-3)}$; by Cauchy Residue Method.

SECTION - II

- Q7) a)** Define and explain the state transition matrix. State its important properties. [6]
- b)** The discrete - time system is represented in state - space form; [10]

$$x(k+1) = \begin{bmatrix} 0 & -0.16 \\ 1 & -1 \end{bmatrix} x(k) + \begin{bmatrix} 0 \\ 1 \end{bmatrix} u(k)$$

- i) Find the state transition matrix $\phi(k)$.
- ii) Obtain the solution of state equation, $x(k)$ if initial conditions $x_1(0) = x_2(0) = 1$.

OR

Q8) a) Derive the expression for Z-transfer function from discrete time state space representation with usual notations; [6]

$$x(k+1) = Gx(k) + Hu(k); Y(k) = Cx(k) + Du(k).$$

b) Draw the state variable diagram in phase variable canonical form and obtain the state variable model using direct decomposition method for system having [10]

$$T(z) = \frac{Y(z)}{U(z)} = \frac{z[z+0.5]}{z^3 - 0.7z^2 - 0.25z + 0.05}$$

Q9) a) Derive the ‘Pulse Transfer Function’ for error sampled unity feedback closed loop control system with forward path linear transfer function G(s). [6]

b) Explain relationship between ‘S’ - plane & ‘Z’ - plane stability. [4]

c) Explain Schurcohn stability criterion for stability of system. [6]

OR

Q10)a) Explain ‘Jury’s stability Test for discrete time system Investigate the stability of system given by:

$$F(z) = z^4 - 1.375z^3 + 0.35z^2 + 0.06z + 0.03 \quad [8]$$

b) Describe the testing of stability of discrete - time control system using Bilinear Transformation. [8]

Apply Bilinear transformation method to find stability of system:

$$F(z) = z^3 - 1.5z^2 - 0.06z + 0.35 = 0.$$

Q11)a) Define the concepts ‘Controllability’ and ‘Observability’ of discrete time control system. Explain Controllability & Observability tests. [4]

b) Investigate the Controllability & Observability of system:- [8]

$$x(k+1) = \begin{bmatrix} 0 & 1 & 0 \\ 0 & 0 & 1 \\ -0.01 & +0.21 & +0.8 \end{bmatrix} x(k) + \begin{bmatrix} 0 \\ 0 \\ 1 \end{bmatrix} u(k); y(k) = [001] x(k)$$

- c) Define the eigen values and obtain the same for the following discrete - time system. [6]

$$x(k+1) = \begin{bmatrix} 0 & 1 & 0 \\ 0 & 0 & 1 \\ 0 & -0.4 & 1.2 \end{bmatrix} x(k) + \begin{bmatrix} 1 \\ 0 \\ 1 \end{bmatrix} u(k)$$

Comment on the stability of the system.

OR

- Q12)a)** Draw appropriate block diagram and explain the PID controller for a digital control system. How to select the constants of digital PID controller? [8]
- b) Derive the transfer function of a digital phase - lead compensating network. [5]
- c) Define the terms, Eigen values, Eigen vectors and Vander Monde Matrix in case of discrete - time system. [5]



Total No. of Questions : 12]

SEAT No. :

P1522

[Total No. of Pages : 3

[4164] - 141

B.E. (Instrumentation & Control)

PROCESS INSTRUMENTATION - I

(2003 Pattern) (Sem. - I)

Time :3 Hours]

[Max. Marks :100

Instructions to the candidates:-

- 1) *Answer three questions from section-I and three questions from section-II.*
- 2) *Answers to the two sections should be written in separate books.*
- 3) *Neat diagrams must be drawn wherever necessary.*
- 4) *Figures to the right indicate full marks.*
- 5) *Use of logarithmic tables, slide rule, Mollier charts, electronic pocket calculator and steam tables is allowed.*
- 6) *Assume suitable data, if necessary.*

SECTION - I

- Q1)** a) Explain the effect of Cavitation and Flashing. Explain the remedial measures to minimize it. [8]
- b) A control valve is used for regulating the liquid flow from a tank. The water level is to be controlled in this tank at a height of 25 feet by regulating the outflow. The measured inflow varies from 0 to 120 gallons per minute. Calculate the C_v and suggest a suitable valve for this application. Instead of the valve discharging to the atmosphere, if it discharges into a second tank with a head of 15 feet and the maximum flow through is 120 gpm. Calculate the C_v and suggest a suitable valve for this application. [8]

OR

- Q2)** a) State various factors considered in testing capacity of a control valve by ISA 75.02. Explain any two factors in detail. [8]
- b) Comment on high temperature and high pressure valves with reference to its applicability. [8]
- Q3)** a) Compare Single Capacity and Multi Capacity Processes. [9]
- b) With a suitable example, explain why dead time dominant processes are difficult to control? [9]

P.T.O.

OR

- Q4)** a) Explain: [9]
- Natural period of oscillation.
 - Time constant.
 - Dead band.
- b) Derive an expression for finding time constant of a level control system. [9]
- Q5)** a) With a suitable application explain the working of a Feed forward Control? What are its limitations? [8]
- b) What is Dual mode Control? Explain with a suitable example. [8]

OR

- Q6)** a) Comment on Selective Control strategy with reference to protection of equipment. [8]
- b) List various methods used for parameter estimation in Adaptive Controller. Explain any one method in detail. [8]

SECTION - II

- Q7)** a) What are the various configurable parameters of MLPC? Explain the significance of each parameter indicating appropriate example. [9]
- b) With the help of necessary equations explain the analysis of a typical Flow Loop. [9]

OR

- Q8)** a) Compare SLPC and MLPC. [9]
- b) Explain the role of 'Scaling'? Explain the various steps involved in scaling in Flow Ratio Control. [9]
- Q9)** a) What is 'MRAC'? Explain with a suitable application how is it applied to a First order system. [8]
- b) Compare Conventional Controllers and Intelligent Controller. [8]

OR

- Q10)**a) What is Predictive Control? Explain its use for improving performance of process. What are its limitations? [8]
- b) Explain the advantages, disadvantages and applications of a Self Tuning Controller. [8]

- Q11)**a) With the help of block schematic, explain the working of Model Predictive Control. [8]
- b) Explain the use of artificial neural network in Process Control considering any typical application. [8]

OR

- Q12)** Write short notes on: [16]
- a) SPC applications.
- b) Fuzzy logic based Controller.



Total No. of Questions : 12]

SEAT No. :

P1523

[Total No. of Pages : 3

[4164] - 195

B.E. (Chemical)

COMPUTER AIDED PROCESS CONTROL

(2003 Pattern) (Elective - II) (Sem. - II)

Time : 3 Hours]

[Max. Marks : 100

Instructions to the candidates:-

- 1) *Answer any 3 questions from each section.*
- 2) *Answers to the two sections should be written in separate books.*
- 3) *Neat diagrams must be drawn wherever necessary.*
- 4) *Figures to the right indicate full marks.*
- 5) *Use of logarithmic tables, slide rule, Mollier charts, electronic pocket calculator and steam tables is allowed.*
- 6) *Assume suitable data, if necessary.*

SECTION - I

- Q1)** a) With neat block diagram, explain basic components of computer control system. [8]
b) Explain centralized and distributed control systems. [8]

OR

- Q2)** a) Explain importance of MMI in computer aided process control systems. [8]
b) Distinguish between DDC & DCS control systems. [8]

- Q3)** a) Define RGA for a 3×3 process having inputs u_1, u_2, u_3 and outputs y_1, y_2, y_3 . State properties of RGA and explain rules for pairing of variables. [8]
b) Define controllability and observability of closed - loop systems. State mathematical conditions for testing controllability and observability. [8]

OR

- Q4)** a) Calculate RGA for the system having open-loop gain matrix. $K = \begin{bmatrix} 12 & -15 \\ 6 & -19 \end{bmatrix}$ Recommend the best pairing of variables. [8]

P.T.O.

- b) A 2×2 system is represented by state space model

$$\dot{X} = AX + Bu \text{ \& } Y = CX,$$

$$\text{Where } A = \begin{bmatrix} 4 & -1 \\ 5 & -2 \end{bmatrix} B = \begin{bmatrix} 1 & 0 \\ 0 & 2 \end{bmatrix} C = \begin{bmatrix} 1 & 0 \\ 0 & 1 \end{bmatrix}.$$

Derive the transfer function model of the system and find its poles and zeros. [8]

- Q5)** a) Explain the function of hold elements in digital control systems. What are ZOH and FOH elements? [6]
b) Explain role of Z-transform in digital control systems. Derive the relationship between Laplace transform and Z-transform. [6]
c) Find inverse Z-transform of the function [6]

$$\hat{Y}(z) = \frac{0.39z^{-1}}{(1-z^{-1})(1-0.61z^{-1})}$$

Using partial fraction method.

OR

- Q6)** Write short notes on the following: [18]
a) Digital PID - controller algorithm.
b) Self tuning digital control systems.
c) Discretization of continuous - time systems.

SECTION - II

- Q7)** a) Explain types of interfaces used in computer process control systems. [8]
b) Explain the components of process control software. [8]

OR

- Q8)** a) Explain various layers used in networking process control systems. [8]
b) Explain communication heirarchy used in computer - aided process control systems. [8]

- Q9)** a) With neat sketch explain basic components of DCS system. [8]
b) Explain PLC architecture. [8]

OR

- Q10)** a) Explain supervisory control systems. [8]
b) Describe I/O systems and modules used in PLC. [8]

Q11) Write short notes on the following: [18]

- a) Temporal hierarchy of control structure.
b) Process control Design Procedure.
c) Control of 2-product distillation column.

OR

Q12) Write short notes on the following:

- a) Heat exchanger control system. [8]
b) Control of jacketed packed bed reactor. [10]



Total No. of Questions : 12]

SEAT No. :

P1524

[Total No. of Pages : 3

[4164] - 255

B.E. (Computer Engineering)

IMAGE PROCESSING

(2003 Pattern) (Elective - I) (Sem. - I)

Time : 3 Hours]

[Max. Marks : 100

Instructions to the candidates:-

- 1) *Attempt Q1 or Q2, Q3 or Q4, Q5 or Q6 from Section I and Q7 or Q8, Q9 or Q10, Q11 or Q12 from Section II.*
- 2) *Answers to the two sections should be written in separate answer books.*
- 3) *Neat diagrams must be drawn wherever necessary.*
- 4) *Assume suitable data, if necessary.*

SECTION - I

- Q1)** a) What is the use of orthogonal Transform in Image processing? Define 2D DCT and discuss its features. [8]
- b) Explain the terms scenes and images. Compare between Monochrome and Colour vision Model. [8]

OR

- Q2)** a) Represent Hadamad matrix of size 8×8 . Discuss its features and applications. [8]
- b) What is the use of membership function in Fuzzy logic? Discuss in brief properties of Fuzzy set. [8]

- Q3)** a) How digital image is presented? Explain the quantization process in image digitization. [8]
- b) Explain the Geometric Model used for Image formation. [8]

OR

- Q4)** a) Define following terms w.r.t. digital image. [8]
- | | |
|----------------------|--------------------------|
| i) distance function | ii) pixel Intensity |
| iii) a frame F | iv) city-block distance. |
- b) Explain the photometric model used for Image formation. [8]

P.T.O.

- Q5)** a) With suitable example, discuss linear and nonlinear histogram stretching method for improving contrast. [10]
b) What is an Image Restoration? Discuss the implementation and use of wiener filter. [8]

OR

- Q6)** a) Compare between Lossy and Lossless Image compression. With algorithm, explain Huffman coding scheme. [10]
b) What is Homomorphic filtering? How it can be used for Image Enhancement? [8]

SECTION - II

- Q7)** a) With suitable algorithms, discuss the methods for finding following geometrical attributes of an image object. [10]
i) area ii) diameter
b) What is Histogram Equalization? Discuss the use of Histogram in Image Segmentation. [8]

OR

- Q8)** a) Discuss in brief the deterministic and statistical approach for Pattern Recognition. Explain in brief K-means clustering algorithm. [10]
b) Describe the region growing technique used for Image Segmentation and state its problems. [8]
- Q9)** a) Discuss the various approaches used for pseudo colour Image Processing. [8]
b) Explain in brief CMY and YIQ colour models. [8]

OR

- Q10)** a) How an image is described by means of a skeleton? Explain one such algorithm in brief. [8]
b) Discuss the following operations w.r.t. binary morphology. [8]
i) Croasion ii) Thinning
iii) Pruning.

Q11) Compare steganography with digital watermarking with suitable algorithms, discuss the process of embedding and extraction for image steganography. **[16]**

OR

Q12) Discuss the use of image processing in multimedia application. Explain the suitable algorithms used for. **[16]**

- a) Preprocessing and
- b) Feature extraction.



Total No. of Questions : 12]

SEAT No. :

P1525

[Total No. of Pages : 3

[4164] - 264

B.E. (Computer Engineering & I.T.)

EMBEDDED SYSTEMS

(2003 Pattern) (Sem. - II) (Elective - II)

Time :3 Hours]

[Max. Marks :100

Instructions to the candidates:-

- 1) *Answers to the two sections should be written in separate answer books.*
- 2) *In section - I attempt: Q.No. 1 or Q.No. 2, Q.No. 3 or Q.No. 4, Q.No. 5 or Q.No. 6. In section - II attempt: Q.No. 7 or Q.No. 8, Q.No. 9 or Q.No. 10, Q.No. 11 or Q.No. 12.*
- 3) *Neat diagrams must be drawn wherever necessary.*
- 4) *Figures to the right indicate full marks.*
- 5) *Assume suitable data, if necessary.*

SECTION - I

- Q1)** a) What are the characteristics of embedded systems? Explain. [8]
b) How ASSP and SOC are different than generic Processors? [4]
c) What TDMI stands for? Describe in brief. [4]

OR

- Q2)** a) With the help of neat diagram, describe different components of embedded systems. [6]
b) What are the features of ARM 7 architecture? [6]
c) Differentiate between CISC and RISC. [4]

- Q3)** a) Explain the process of converting the following with the help of neat diagram: [12]
i) C program into a file for ROM image.
ii) Assembly program into a file for ROM image.
b) What do you mean by charge pump? How does it supply power to an embedded system. Explain with an example. [6]

OR

P.T.O.

- Q4)** a) Justify various types of memories required with specific use in the following applications. [6]
i) Digital Camera ii) Smart card
b) How does clock unit can affect the performance of an embedded system?[6]
c) What is DMA? What is its role in an embedded system? [6]

- Q5)** a) What are the different standards available for serial & parallel I/O? What are the applications of these I/O methods. [6]
b) Describe the following IPC mechanisms: [6]
i) Mutex ii) Pipes
c) How optical devices are used for isolating electronic circuits? [4]

OR

- Q6)** a) What do you mean by Context, Interrupt Latency and Deadline? [6]
b) List and describe five types of device driver functions. [6]
c) Name and Explain topology implemented in USB protocol. [4]

SECTION - II

- Q7)** a) What are the different phases of software development cycle for a typical embedded system? [8]
b) Explain the use of Java language for embedded system? What are the disadvantages of using Java? [6]
c) What is an IDE (Integrated Development Environment)? What does it consist of? [4]

OR

- Q8)** a) Explain the advantages of using C language instead of assembly language in embedded system programming? [6]
b) What is cross compiler? How it is different than generic compiler? [6]
c) What are the different ways to debug the embedded system software?[6]

- Q9)** a) With the help of neat diagram, explain cyclic scheduling with time slicing model for RTOS. [8]
b) List the different features of embedded OS? How it is different than desktop OS? [8]

OR

- Q10)a)** With the help of neat diagram, explain Cooperative ordered list scheduling model for RTOS. [8]
- b) What are the different ways to handle interrupts in RTOS environment?[8]

- Q11)a)** Differentiate MicroC/OS-II and VxWorks based on features and their area of application. [6]
- b) With the help of neat system block diagram, explain the system requirements and tasks for chocolate vending machine. [10]

OR

- Q12)a)** How tasks are managed in MicroC/OS-II? Explain in detail. [8]
- b) With help of neat diagram, explain synchronization of tasks and IPCs for chocolate vending machine. [8]



Total No. of Questions : 12]

SEAT No. :

P1526

[Total No. of Pages : 2

[4164] - 271

B.E. (IT)

INFORMATION SYSTEM SECURITY

(2003 Pattern) (Sem. - I)

Time :3 Hours]

[Max. Marks :100

Instructions to the candidates:-

- 1) *Solve any three from each section.*
- 2) *Figures to the right indicate full marks*

SECTION - I

- Q1)** a) Explain Classical Crypto System. [9]
b) Explain Security Policy and its importance. [9]

OR

- Q2)** a) Explain Clinical Information Systems Security Policy. [9]
b) Explain in Biba Integrity Model. [9]

- Q3)** a) Draw virus classification and explain. [8]
b) Explain any security standards and its services offered. [8]

OR

- Q4)** a) Describe how the access control is implemented. [8]
b) Illustrate the message digest system. [8]

- Q5)** a) Explain basics to advanced authentication ideas. [8]
b) List at least four top security challenges. [8]

OR

- Q6)** a) Write the Methods of Asymmetric Key Distribution. [8]
b) Explain host to host and network to network IPSEC system. [8]

P.T.O.

SECTION - II

- Q7)** a) What is traditional Operating System Security arrangements. [9]
b) List and state the Security certificates available commercially. [9]

OR

- Q8)** a) List and state security design principles. [9]
b) List and state Key management functions. [9]

- Q9)** a) Describe Auditing with example. [8]
b) What is importance of Trust. [8]

OR

- Q10)**a) Public key systems are better for authentication than for Encryption. Justify. [8]
b) Explain types of Intrusion Detection Systems. [8]

- Q11)**a) Describe the Universal Identity management system. [8]
b) Describe Identity Management Techniques. [8]

OR

- Q12)**a) Write short note on Vulnerability Classification. [8]
b) Write short note on Penetration tools. [8]



Total No. of Questions : 12]

SEAT No. :

P1610

[Total No. of Pages : 2

[4164] - 11

B.E. (Civil)

GEOINFORMATICS

(Elective - I) (2003 Pattern) (Sem. - I)

Time : 3 Hours]

[Max. Marks : 100

Instructions to candidates:

- 1) Answer any three questions from each Section.
- 2) Answers to the two sections should be written in separate books.
- 3) Neat diagrams must be drawn wherever necessary.
- 4) Figures to the right indicate full marks.
- 5) Assume suitable data, if necessary.

SECTION - I

- Q1)** a) Explain EMS. State the characteristics of different frequencies. [10]
b) Define resolution and explain any 2 types. [8]

OR

- Q2)** a) What are the elements of Visual Image interpretation? Explain their significance and factors influencing them. [10]
b) Explain interaction of EMR with Earth's Surface. [8]

- Q3)** a) What is Contrast image enhancement? Explain it in detail. [8]
b) Write a note on: [8]
i) Image Rectification.
ii) Geo referencing.

OR

- Q4)** a) Explain the term "Histogram Equalization". Elaborate the Linear and Non Linear contrast stretch enhancement. [8]
b) Explain Unsupervised Classification. [8]

- Q5)** a) Explain with neat sketches the working of GPS in association with: [9]
i) GPS Space Segments.
ii) GPS Control Segments.
iii) User Segments.
b) What are applications of GPS in Civil Engineering? [7]

P.T.O

OR

- Q6)** a) What are the different types of errors in GPS observations and explain how to minimize it? [10]
b) Write a note on Codes used in GPS. [6]

SECTION - II

- Q7)** a) What is a Map? Explain different types of Map Projection Systems and its need? [10]
b) Explain: [8]
i) Digital Image Processing.
ii) Vector Model.

OR

- Q8)** a) What is GIS? Explain in detail its components. [10]
b) Write a note on: [8]
i) Data types in DBMS.
ii) Attributes.

- Q9)** a) Explain any one GIS software's and write a detail account on its Modules. [12]
b) What are the components of DBMS? [4]

OR

- Q10)** a) What is RDBMS? Explain the Normal form of RDBMS with one example. [12]
b) Write a Note on Primary Key and Foreign Key. [4]

- Q11)** Explain application of Geo Informatics in following areas: [16]
a) Integrated Resource Development and Management.
b) Investigations of Dam sites.

OR

- Q12)** Explain application of Geo Informatics with working flow charts in following areas: [16]
a) Town Planning.
b) Survey and Investigations.



Total No. of Questions : 12]

SEAT No.:

P1613

[Total No. of Pages : 2

[4164]-51
B.E. (Production)
PRODUCTION MANAGEMENT
(2003 Pattern) (Sem. - I)

Time : 3 Hours]

[Max. Marks : 100

Instructions to the candidates:

- 1) *Answer any three questions from each section.*
- 2) *Answer three questions from section-I and three questions from section-II.*
- 3) *Answers to the two sections should be written in separate books.*
- 4) *Neat diagrams must be drawn wherever necessary.*
- 5) *Figures to the right indicate full marks.*
- 6) *Your answers will be valued as a whole.*
- 7) *Use of logarithmic tables slide rule, Mollier charts, electronic pocket calculator and steam tables is allowed.*
- 8) *Assume suitable data, if necessary.*

SECTION - I

Unit - I

- Q1)** a) What is the scope of production/operation management? Explain in brief. [6]
b) What are the duties of production manager? [6]
c) What are the factors that influence the product design? Explain. [6]

OR

- Q2)** a) Explain evolution stages of production management. [9]
b) Explain standardization, simplification and specialization in relation to product design and development. [6]
c) Draw a functional organisational structure for a multi-product organisation for a large scale business. [3]

Unit - II

- Q3)** a) Explain factors to be considered for selecting the location to start foundry. [8]
b) Enumerate the different principles of material handling. Explain any four in brief. [8]

OR

- Q4)** a) Explain different quantitative methods/models used in solving facility layout problem. [8]

P.T.O.

- b) Explain how material handling problems analysed. [8]

Unit - III

- Q5)** a) Explain long term and short term capacity strategies used in industries. [8]
b) Define productivity. Enumerate different productivity improvement techniques? Explain technology based tools in brief. [8]

OR

- Q6)** a) What are the internal and external productivity factors? Explain with block diagrams. [8]
b) Explain with block diagram Human Resource Planning. [8]

SECTION - II

Unit - IV

- Q7)** a) What are the “First Principles of World Class Manufacturing”? Explain in brief. [9]
b) Explain Hall’s framework of value Added Engineering. [9]

OR

- Q8)** a) Explain in brief the evaluation of WCM-World Class Manufacturing. [9]
b) Explain the operation assumptions given by Kaplan and Norton (1996) in order to compute in the information age. [9]

Unit - V

- Q9)** a) Explain the difference between preventive maintenance and breakdown maintenance. [8]
b) Explain different factors considered while preparing maintenance schedule. [8]

OR

- Q10)** a) Explain how maintenance cost is estimated? [8]
b) Explain objectives and benefits of total productive maintenance (TPM). Also explain 6 big losses eliminated in (TPM). [8]

Unit - VI

- Q11)** a) Explain simple walk through energy audit. [8]
b) Explain in brief what is sustainable manufacturing? [8]

OR

- Q12)** a) Explain the features of lean manufacturing with its benefits and demerits. [8]
b) How environmental pollution is classified? Explain. [8]



Total No. of Questions : 12]

SEAT No. :

P1615

[Total No. of Pages : 3

[4164] - 87

B.E. (Electrical)

ILLUMINATION ENGINEERING

(Elective - I) (2003 Pattern) (Sem. - I)

Time : 3 Hours]

[Max. Marks : 100

Instructions to candidates:

- 1) *Answer any three questions from each Section.*
- 2) *Answers to the two sections should be written in separate books.*
- 3) *Neat diagrams must be drawn wherever necessary.*
- 4) *Figures to the right indicate full marks.*
- 5) *Use of logarithmic tables slide rule, Mollier charts, electronic pocket calculator and steam tables is allowed.*
- 6) *Assume suitable data, if necessary.*

SECTION - I

- Q1)** a) Explain properties of light. [6]
b) Compare artificial light with natural light. [6]
c) State and explain the laws of illumination. [6]

OR

- Q2)** a) Explain various methods of controlling natural light. [6]
b) Define and explain - plane angle, solid angle. Derive relationship between these two. [6]
c) Discuss the importance of light in human life with respect to various activities. [6]

- Q3)** a) With a suitable diagram explain constructional details of tungsten halogen lamp. Explain the working of this lamp. State the types of tungsten halogen lamp. [8]
b) Distinguish between the incandescent lamp and fluorescent lamp. [6]
c) What is stroboscopic effect? [2]

OR

- Q4)** a) With a suitable diagram explain constructional details of compact fluorescent lamp (CFL). State the advantages of this lamp. State typical ratings of CFL. [8]
b) Describe construction and working of LED. State its advantages and applications. [6]

P.T.O

- c) Draw a circuit diagram showing connections of fluorescent tube with choke and starter. [2]

- Q5)** a) Explain starting gear and dimming for sodium vapour lamp and metal halide lamp. [8]
 b) Explain the following with neat sketches. [8]
 i) Specular reflection.
 ii) Diffused reflection.

OR

- Q6)** a) What are reflectors and refractors in context with illumination? State and elaborate their importance. [8]
 b) With neat sketches, explain various types of light fittings used for illumination. [8]

SECTION - II

- Q7)** a) A drawing hall of 30m x 13m with ceiling height of 5 meter is to be illuminated for 120 lux. Taking coefficient of utilization of 0.5 and depreciation factor of 1.4, determine the number of fluorescent tubes required, their spacing and mounting height and total wattage. Take luminous efficiency of fluorescent tube as 40 lumen/watt. Use twin tube fitting i.e. wattage per fitting equal to 80 watt. Assume mounting height = 3m. [8]
 b) What is glare? Discuss different types of glare and remedies to reduce glare. [8]

OR

- Q8)** a) A hall of 30m x 12m is to be illuminated for illumination of 50m candles. Take depreciation factor = 1.3 and utilization factor 0.5. Find the number of lamps and show the disposition of lamps. Refer following table for selecting luminarie. [8]

Watt	100	200	300	500	1000
Lumens	1615	3650	4700	9950	21500

- b) What is polar curve? Describe its types. How it is helpful for illumination work? [8]
- Q9)** a) Explain zonal flux method for area lighting. [8]
 b) With suitable example explain Payback, calculation, life cycle costing. [8]

OR

- Q10)** a) What is energy efficient lighting? State its advantages. [8]
b) Explain procedure for street lighting using COU. [8]

Q11) Write short notes on:

- a) Cold lighting. [6]
b) Photo voltaic lighting. [6]
c) Optical Fiber Cable lighting. [6]

OR

Q12) Write short notes on:

- a) Solar lighting. [6]
b) Emergency lighting. [6]
c) Components of day light factor. [6]



Total No. of Questions : 12]

SEAT No.:

P1621

[Total No. of Pages : 2

[4164]-149
B.E. (Instrumentation & Control)
PROCESS INSTRUMENTATIONS - II
(2003 Pattern) (Sem. - II)

Time : 3 Hours]

[Max. Marks : 100

Instructions to the candidates:

- 1) Answers to the two sections should be written in separate books.*
- 2) Neat diagrams must be drawn wherever necessary.*
- 3) Figures to the right indicate full marks.*
- 4) Your answers will be valued as a whole.*

SECTION - I

Q1) Explain any two control and instrumentation schemes for heat-exchangers with diagrams. **[18]**

OR

Q2) Draw basic refrigeration cycle and explain operation of chiller. Also mention refrigerent names. **[18]**

Q3) How safety is assured in chemical reactor instrumentation, explain. **[16]**

OR

Q4) Enlist different color codes used in chemical reactor control piping system. **[16]**

Q5) Discuss various capacity control schemes for pumps. **[16]**

OR

Q6) Enlist different specifications of a typical compressor. **[16]**

SECTION - II

Q7) Explain the importance of Boiler Safety Management System. **[18]**

OR

Q8) Explain cross limited parallel metering in boiler instrumentation with diagram. **[18]**

P.T.O.

Q9) How PLC programming is possible with autioneering system? Assume three temperature transmitters used in such application. Draw such system; also draw PLC function block for the same. **[16]**

OR

Q10) Draw and explain various distillation column control systems (any two) :**[16]**

Q11) Where are evaporators used? How instrumentation is applied in evaporators? Explain. **[16]**

OR

Q12) Enlist different types of dryers and explain any one in detail. **[16]**

☒☒☒☒

Total No. of Questions : 8]

SEAT No. :

P1677

[Total No. of Pages : 2

[4164]-222

B.E. (Petrochemical Engineering)
PETROCHEMICAL PROCESSES
(2003 Pattern) (Sem. - I)

Time :3 Hours]

[Max. Marks :100

Instructions to the candidates:

- 1) *Answer any three questions from each section.*
- 2) *Answers to the two sections should be written in separate books.*
- 3) *Neat diagrams must be drawn wherever necessary.*
- 4) *Figures to the right indicate full marks.*

SECTION - I

- Q1)** a) Describe with flowsheet the oxidation process for conversion of methanol to formaldehyde. [12]
b) Mention end uses of isopropanol, butadiene and ethylene glycol. [6]
- Q2)** a) Describe with flowsheet the BASF process for manufacture of isoprene from steam cracked C₅ cut. [12]
b) Write a note on Xylene isomerization. [4]
- Q3)** a) Describe the process of steam reforming for production of hydrogen. [12]
b) Mention end uses of methanol and ethylene oxide. [4]
- Q4)** a) Describe with flowsheet the process for conversion of toluene to benzene by hydrodealkylation. [12]
b) Mention health and handling precautions for acrylonitrile. [4]

SECTION - II

- Q5)** a) Describe with flowsheet the oxidation process for conversion of cumene to acetone. [12]
b) Explain the role of steam in steam cracking of naphtha. [6]

P.T.O.

- Q6)** a) Describe with flowsheet the low pressure Ziegler process for conversion of ethylene to polyethylene. [12]
b) Write a short note on thermoplastics and thermosets. [4]
- Q7)** a) Describe with flowsheet the sohio process for conversion of propylene to acrylonitrile. [12]
b) Write a note on Gas Hydrate as a novel energy source. [4]
- Q8)** a) Explain the process for preparation of nylon 66. [8]
b) Write a note on autothermal reactor. [4]
c) Mention end uses of styrene and acetic anhydride . [4]

* * *

Total No. of Questions : 12]

SEAT No. :

P1682

[Total No. of Pages : 3

[4164] - 253

B.E. (Computer Engg.) (Common to I.T.)
OBJECT ORIENTED MODELING AND DESIGN
(2003 Pattern) (Sem. - I)

Time : 3 Hours]

[Max. Marks : 100

Instructions to the candidates:-

- 1) *Answer 3 questions from section I and 3 questions from section II.*
- 2) *Answers to the two sections should be written in separate books.*
- 3) *Neat diagrams must be drawn wherever necessary.*
- 4) *Figures to the right indicate full marks.*
- 5) *Assume suitable data, if necessary.*

SECTION - I

- Q1)** a) Explain the 4+1 architecture with applicable UML diagrams in each view. [6]
b) Give the features of UML 2.0. [6]
c) What is UML? What is the importance of modeling in Software development. [4]

OR

- Q2)** a) Explain the phases of Rational unified process. [6]
b) What is the need of standardization in software modeling? How it is supported by the development of UML? [6]
c) What do you mean by MDA? [4]

- Q3)** a) Explain the following in brief with the notations. [8]
i) Things in UML. ii) Stereotypes.
b) Explain the structural diagrams in UML. [8]

OR

- Q4)** a) Give the Extensibility mechanisms in UML. [8]
b) What is behavioral modeling? How it is supported by UML? [8]

P.T.O.

- Q5)** a) Explain the relationships used in a class diagram with example. [8]
b) Identify the classes for a library system. Give the class diagram by identifying relationships between these classes. [6]
c) Differentiate between interface and class. [4]

OR

- Q6)** a) Define the following with the notations. [8]
i) Class ii) Generalization
iii) Composite structure iv) CRC
b) Explain the object diagram with an example. [6]
c) Differentiate between aggregation and composition. [4]

SECTION - II

- Q7)** a) Explain the sequence diagram elements in an interaction with an example. [8]
b) Explain the interaction overview diagram. [4]
c) Give the application of Communication diagram. [4]

OR

- Q8)** a) Identify the objects and messages for a “student course registration sequence” in a “Course management system” and represent it using the sequence diagram. [8]
b) Differentiate between communication and sequence diagram. [4]
c) Give the use of operators in sequence diagram. [4]

- Q9)** a) Explain the following with respect to state machine. [8]
i) Sub States ii) History states
iii) Self transition iv) Entry action
b) Give the state diagram for a printer for printing a document. [6]
c) What are the elements of an activity diagram in UML 2.0? [4]

OR

- Q10)**a) Give the activity diagram for authentication of user in an email system. **[8]**
b) Explain the timing diagram with its applications. **[6]**
c) How do you partition the activity diagrams? **[4]**

- Q11)**a) Explain the deployment diagram elements with an example. **[8]**
b) What do you mean by a component? How component diagram is used in modeling? **[8]**

OR

- Q12)**a) Explain the concept of forward and reverse engineering. **[8]**
b) Explain the application of UML in embedded systems. **[8]**



Total No. of Questions : 12]

SEAT No.:

P1710

[Total No. of Pages : 2

[4164]-9
B.E. (Civil)
ARCHITECTURE AND TOWN PLANNING
(2003 Pattern) (Elective - I) (Sem. - I)

Time : 3 Hours]

[Max. Marks : 100

Instructions to the candidates:

- 1) *Answers to the two sections should be written on separate answer sheets.*
- 2) *Solve Q. 1 or Q. 2, Q. 3 or Q. 4, Q. 5 or Q. 6 from section-I and Q. 7 or Q. 8, Q. 9 or Q. 10, Q. 11 or Q. 12 from section-II.*
- 3) *Figures to the right indicate full marks.*
- 4) *Assume suitable data if necessary.*

SECTION - I

- Q1)** a) What are different qualities of architecture? [6]
b) Explain the important principles of architecture. [6]
c) Write a short note on Renaissance Architecture. [5]
- OR
- Q2)** a) Explain the importance of Architectural composition. [6]
b) Explain the features of Gothic Architecture. [6]
c) Explain the impact of factors of Architecture on Architectural composition. [5]
- Q3)** a) What is connectivity matrix? Explain the importance of the same for a 500 bedded hospital in metrocity. [9]
b) Explain the relation between climatic factors and design of the buildings [8]
- OR
- Q4)** a) Explain various planning concepts used for neighbourhood. [9]
b) Write the importance of solar passive Architecture for the areas like Simla, Mahabaleshwar. [8]
- Q5)** Write short notes on : [16]
a) Essentiality of bye Laws and Acts.
b) Three magnet theory.
c) Importance of zoning.
d) Surveys prior to D.P.

P.T.O.

OR

- Q6)** a) What is Built Environment? State its importances while developing a town.
b) Write a note on DP and UDPFI guidelines. [16]

SECTION - II

- Q7)** a) State and explain two principles of landscaping. [8]
b) State and explain soft landscaping techniques. [8]

OR

- Q8)** a) Explain the stages involved while preparing a landscaping plan.
b) “Efforts of landscape designer for city lungs”. Explain. [16]

- Q9)** a) Write a note on traffic management in case of metro city.
b) “Effective use of TPS”. Explain. [16]

OR

- Q10)** a) Write a note on “Importance of MRTP in preparation of DP.
b) Services in urban areas under D.P. [16]

- Q11)** a) Write short note on “use of softwares in planning.
b) Importance of GIS in Transportation Planning. [18]

OR

- Q12)** Write short notes on : [18]
a) GPS segment.
b) Use of satellite imagery.
c) GIS use for data collection-analysis and planning of a town.



Total No. of Questions : 12]

SEAT No.:

P1714

[Total No. of Pages : 2

[4164]-187
B.E. (Chemical Engineering)
ENERGY CONSERVATION
(2003 Pattern) (Elective - I) (Sem. - I)

Time : 3 Hours]

[Max. Marks : 100

Instructions to the candidates:

- 1) *Answer any three questions from each section.*
- 2) *Neat diagrams must be drawn wherever necessary.*
- 3) *Figures to the right indicate full marks.*
- 4) *Assume suitable data, if necessary.*

SECTION - I

- Q1)** a) Describe the method of solar drying? Discuss the factors considered for the design of solar dryer? **[10]**
- b) Wind at 1 standard atmospheric pressure and 15°C has a velocity of 15m/s Calculate : **[8]**
- i) The total power density in the wind stream.
 - ii) The maximum obtainable power density.
 - iii) A seasonally obtainable power density.
 - iv) The total power.
 - v) The torque and axial thrust.
- Given :** Turbine diameter : 120m, and turbine operating speed = 40 rpm at maximum efficiency. Propeller type wind turbine is considered.

OR

- Q2)** a) Discuss in detail about solar distillation with neat diagram. **[10]**
- b) Explain the geothermal energy in detail? **[8]**
- Q3)** a) Explain the role, types, design and material of absorption plate in solar flat plate collector? **[8]**
- b) Explain the various zones of gasification along with temperature and its significance? **[8]**

OR

P.T.O.

- Q4)** a) Explain the various nuclear reactions for energy generation? [6]
b) What are different methods of biochemical energy generation? Discuss their advantages and disadvantages. [10]

Q5) What are the types of recuperators for waste heat recovery? Explain any two in detail. [16]

OR

- Q6)** a) Distinguish between waste heat recovery boiler and Economizer? [8]
b) Explain in detail the efficient use of steam condensate in chemical plant?[8]

SECTION - II

- Q7)** a) Explain condensate heat recovery reduces boiler fuel consumption? Describe with neat sketches different condensate recovery systems?[10]
b) Explain the concept of cogeneration and their types with neat diagram. Discuss its significance in sugar industry. [8]

OR

Q8) Explain the energy performance assessment of heat exchanger and discuss the steps involved in pinch analysis? [18]

- Q9)** a) Justify that “steam trap” and “pressure reducing valves” (PRV) are energy conservation devices? [8]
b) Explain the energy conservation Act of Govt. of India? [8]

OR

- Q10)** a) Explain with suitable diagram and description that “Steam pressure reducing station” help in energy optimization? [8]
b) Explain the consumption and conservation of energy in petroleum industry? [8]

Q11) Distinguish between ‘Macro Audit’ and ‘Micro Audit’. Write down the steps followed for carrying out energy audit of plant along with detailed flow chart? [16]

OR

- Q12)** Write short notes on (any two) : [16]
a) Role of insulation in energy conservation.
b) Fluidized bed combustion.
c) Optimizing the energy input requirement.

XXXX

Total No. of Questions : 12]

SEAT No. :

P1718

[Total No. of Pages : 2

[4164] - 258

B.E. (Computer Engg.)

MULTIMEDIA SYSTEMS

(Elective - I) (2003 Pattern) (Sem. - I)

Time : 3 Hours]

[Max. Marks : 100

Instructions to candidates:

- 1) *Answer any three questions from each Section.*
- 2) *Answers to the two sections should be written in separate books.*
- 3) *Neat diagrams must be drawn wherever necessary.*
- 4) *Figures to the right indicate full marks.*
- 5) *Assume suitable data, if necessary.*

SECTION - I

- Q1)** a) State and explain basic components of multimedia. [6]
b) What are multimedia authoring tools? State and explain various types of multimedia authoring tools. [6]
c) Explain characteristics of multimedia presentation. [6]

OR

- Q2)** a) Explain the architecture of distributed multimedia system and their applications. [9]
b) State and explain different applications of Multimedia over internet. [9]

- Q3)** a) Explain image enhancement using pointprocessing. Also explain image negation and contrast stretching. [8]
b) Explain Shannon Feno and arithmetic coding compression techniques in detail. [8]

OR

- Q4)** a) Explain BMP and TIFF file format in detail. [8]
b) Explain color image processing in detail. [8]

- Q5)** a) State and explain properties of sound waves. [8]
b) Explain WAV and AVI file format in detail. [8]

OR

P.T.O

- Q6)** a) What is MIDI? Explain channel message and system message. [8]
b) Write and explain different elements of audio system. [8]

SECTION - II

- Q7)** a) State different text file formats. Explain any two in detail. [8]
b) Write and compare different television broadcasting standards. [8]

OR

- Q8)** a) Explain any two text compression techniques in detail. [8]
b) Explain MPEG encoder and decoder with block diagram. [8]

- Q9)** a) What is VRML? Write VRML code to create virtual coffee house. [8]
b) What do you mean by VR devices? Explain head mounted devices with its features. [8]

OR

- Q10)** a) Write features of VRML with example. [8]
b) Differentiate between virtual reality and augmented reality with example. [8]

- Q11)** a) Explain principles of animation with example. [8]
b) Discuss the issues of development of animation on web? Compare client pull and server push animations. [10]

OR

- Q12)** a) Explain the role of linear interpolation and Spline interpolation in animation? Also explain what ease-in is and ease-out effect. [8]
b) What is 3D animation? Explains how atmospheric effect can be introduced in animation. [10]



Total No. of Questions : 12]

SEAT No. :

P1720

[Total No. of Pages : 3

[4164] - 261

B.E. (Computer Engg.)

SOFTWARE TESTING AND QUALITY ASSURANCE

(2003 Pattern) (Sem. - II)

Time : 3 Hours]

[Max. Marks : 100

Instructions to candidates:

- 1) *Answer any three questions from each Section.*
- 2) *Answers to the two sections should be written in separate books.*
- 3) *Neat diagrams must be drawn wherever necessary.*
- 4) *Figures to the right indicate full marks.*

SECTION - I

- Q1)** a) Explain various measurement scales in detail with suitable examples. [8]
b) What is good data and how to define it? How to collect and store data? Explain. [10]

OR

- Q2)** a) What is meant by direct and indirect measurement? Explain in detail. What is difference between measurement and calculations. [6]
b) Explain four principles of investigation. What are types of investigations? [6]
c) In detail give classification of software measures. [6]

- Q3)** a) Explain Halstead's major equation for following: [12]
i) Total vocabulary.
ii) Length.
iii) Volume.
iv) Level.
v) Difficulty.
vi) Efforts.
vii) Faults.

Calculate estimated program length and efforts required by taking suitable example.

- b) Explain "Object oriented metrics". [4]

OR

P.T.O

- Q4)** a) Explain aspects of software size, length, reuse, functionality and complexity in detail. [10]
b) What is the “Halstead’s software Science”. [6]

- Q5)** a) Explain defect classes and origins of defects in detail along with example and defect life cycle. [8]
b) Write short note on: [8]
 - Boundary value analysis.
 - Equivalence Partitioning.

OR

- Q6)** a) Explain Goal-Question-Metric model in detail by taking suitable example. [8]
b) Explain in short: [6]
 - White box testing.
 - Black - box testing.
c) What is metric plan? [2]

SECTION - II

- Q7)** Take example of online railway reservation system write suitable scope statement for the same. Write all assumptions and identify two test cases for each of the following: [18]
a) Acceptance Testing.
b) GUI Testing.
c) Usability and accessibility.
d) Ad - hoc Testing.

OR

- Q8)** a) State the importance of software test automation. [6]
b) Take example of hypothetical library software development project and describe briefly the following terms: [12]
 - i) Integration testing.
 - ii) Black box testing.
 - iii) Stress testing.
 - iv) Beta testing.

Q9) Explain the use of following with example. **[16]**

- a) Scatter diagram.
- b) Histogram.
- c) Run charts.
- d) Cause-effect diagram.
- e) Checklists.
- f) Pareto diagram.
- g) Control charts.

OR

Q10) a) Explain with examples “six sigma measure of software quality”. **[8]**

b) How does ISO 9000/9001 standard ensure in producing a good quality software. **[8]**

Q11) a) What are the challenges and best practices for software maintenance. **[8]**

b) What do you mean by problem fixing and explain the process of problem fixing and reporting. **[8]**

OR

Q12) a) Write short notes on: **[10]**

i) Fix distribution.

ii) Challenges and best practices in problem resolution.

b) Is software maintenance important and critical phase of software development life cycle (SDLC)? Comment. **[6]**



Total No. of Questions : 12]

SEAT No. :

P1723

[Total No. of Pages : 2

[4164] - 280

B.E. (IT)

INFORMATION RETRIEVAL

(2003 Pattern) (Sem. - II)

Time : 3 Hours]

[Max. Marks : 100

Instructions to candidates:

- 1) Answer any three questions from each Section.
- 2) Answers to the two sections should be written in separate books.
- 3) Neat diagrams must be drawn wherever necessary.
- 4) Figures to the right indicate full marks.
- 5) Assume suitable data, if necessary.

SECTION - I

- Q1)** a) Explain Rochhio's algorithm. [8]
b) Is it important to consider frequency of occurrence of words while building document representative? Should a term occurring more frequently in a longer document be considered more relevant than the same term occurring little less frequently in a smaller document? [8]

OR

- Q2)** a) Which are the words that should be considered as stop words? Mention strategies to decide the stop words and stemming. [8]
b) Explain Single-Pass algorithm. [8]

- Q3)** a) Describe Fuzzy set model. [8]
b) How is XML important in Information Retrieval? Explain XML data model. [10]

OR

- Q4)** a) Describe Boolean and vector model. [8]
b) Consider five document representatives having five keywords each. Show how to construct inverted index. State how they are useful in IR. [10]

- Q5)** a) What is user oriented measure? Explain relative recall and recall effort. [8]
b) Discuss Retrieval Performance evaluation. [8]

OR

P.T.O

- Q6)** a) What are the different starting points for search interfaces? [8]
b) Write short notes on: Dendograms and TREC collections. [8]

SECTION - II

- Q7)** a) Discuss online IR systems. [8]
b) Write a note on OPACs and MARC record. [8]

OR

- Q8)** a) Discuss document models in digital libraries. [8]
b) Explain: digital libraries prototypes and representations. [8]

- Q9)** a) Explain generic multimedia index approach. [9]
b) Explain GEMINI algorithm. State its use. [9]

OR

- Q10)** Write short notes on: [18]
a) Query specification.
b) MULTOS.

- Q11)** a) Explain meta searchers. [8]
b) Compare parallel and distributed IR. [8]

OR

- Q12)** a) Explain source selection with respect to Distributed IR. [8]
b) Write notes on : Suffix arrays and MIMD architecture. [8]



Total No. of Questions : 12]

SEAT No. :

P1759

[Total No. of Pages : 2

[4164]-58

B.E. (Production Engineering)

**MATERIAL HANDLING TECHNOLOGY AND EQUIPMENT DESIGN
(2003 Pattern) (Elective - I) (Sem. - I)**

Time :3 Hours]

[Max. Marks :100

Instructions to the candidates:

- 1) *Answer any 3 questions from each section.*
- 2) *Answer 3 questions from Section I and 3 questions from Section II.*
- 3) *Neat diagrams must be drawn wherever necessary.*
- 4) *Figures to the right indicate full marks.*

SECTION - I

- Q1)** a) Define material handling process? Explain as to why it is required in a production system? [10]
b) State the nature of movement of a material and how it is classified. [8]

OR

- Q2)** a) What are the different factors considered in planning fixed path equipment. [10]
b) Explain the advantages of unit load concept with a neat example. [8]

- Q3)** a) Explain why one needs avoid rehandling and backtracking? [10]
b) Explain the concept utilization of line storage with a neat example. [6]

OR

- Q4)** a) Explain material handling check list with a neat example. [10]
b) What is design of containerization? Explain properly. [6]

- Q5)** a) Explain apron and pan conveyors used in material handling system. [10]
b) Explain straight chutes and spiral chutes used in conveyor system. [6]

OR

- Q6)** a) Explain block and tackle, winches types of hoists used in material handling system. [10]
b) Briefly explain fork lift trucks used as material handling equipment. [6]

P.T.O.

SECTION - II

Q7) a) Why automating of material handling system is a must in current working condition? Explain properly. [10]

b) What are the design considerations for bulk material handling? [8]

OR

Q8) a) What kind of justification one can give for implementing automated material handling system? Explain properly. [10]

b) What are actuators? and explain types of actuators used in material handling system. [8]

Q9) a) Explain the term automated guided vehicle (i.e. AGV) and discuss the merits and demerits of AGV. [10]

b) Briefly explain types of AGV (i.e. automated guided vehicle). [6]

OR

Q10) a) What is interfacing of material handling equipment with manufacturing equipment? State its advantages. [10]

b) What is the use of adaptive control system? Briefly explain. [6]

Q11) a) Explain computer application in packaging and state its advantages. [10]

b) What is auto identification system? Where it is used? [6]

OR

Q12) a) What are the safety aspects considered while designing material handling equipment? Explain with an example. [10]

b) State the environmental factors considered while operating a handling equipment. [6]

Total No. of Questions : 8]

SEAT No.:

P1760

[Total No. of Pages : 1

[4164]-201
B.E. (Petroleum Engineering)
RESERVOIR ENGINEERING - I
(2003 Pattern) (Sem. - I)

Time : 3 Hours]

[Max. Marks : 100

Instructions to the candidates:

- 1) *Answers to the two sections must be written in separate answer books.*
- 2) *Questions No. 2 (two) and 8 (eight) are compulsory.*
- 3) *Figures to the right indicate full marks.*
- 4) *Neat diagrams should be drawn wherever necessary.*
- 5) *Use of a non-programmable calculator, log-log, semi-log paper is allowed.*
- 6) *Assume suitable data if necessary.*

SECTION - I

- Q1)** What is reservoir engineering? **[16]**
- Q2)** Derive the material balance equation for a reservoir producing with combination of all the drive mechanisms. Explain its interpretation. **[18]**
- Q3)** Derive the material balance equation for an oil reservoir operating rock and fluid expansion. **[16]**
- Q4)** State and explain the type curves used in decline curve analysis. **[16]**

SECTION - II

- Q5)** Derive the diffusivity equation in cylindrical coordinate system. **[16]**
- Q6)** For a pressure drawdown test explain the terms ETR, MTR and LTR on a semi log, log plot and on the derivative plot. **[16]**
- Q7)** Explain gas well testing. **[16]**
- Q8)** Write short notes on : **[18]**
- a) Type curves.
 - b) Pulse test analysis.



Total No. of Questions : 8]

SEAT No.:

P1763

[Total No. of Pages : 2

[4164]-221
B.E. (Petrochemical)
REFINING OPERATIONS
(2003 Pattern) (Sem. - I)

Time : 3 Hours]

[Max. Marks : 100

Instructions to the candidates:

- 1) Attempt any three questions from each section.*
- 2) Answer to the two sections should be written in two separate answer books.*
- 3) Figures to the right indicate full marks.*
- 4) Use of steam tables and electronic calculator is allowed.*
- 5) Assume suitable data wherever necessary.*

SECTION - I

- Q1)** a) Discuss crude desalting operation in detail. **[12]**
b) Explain in brief the advantages of crude desalting. **[4]**
- Q2)** Explain in detail the products of, tray arrangements in, side stripping and reflux arrangement in operation of atmospheric distillation unit. **[18]**
- Q3)** Discuss emerging trends in environmental specifications of any four fuel products and their impact on refinery operations. **[16]**
- Q4)** Write notes :
- a) Vacuum Devices. **[5]**
 - b) Structured Packings for Vacuum distillation. **[5]**
 - c) Grass-root refinery. **[6]**

SECTION - II

- Q5)** Explain important hydro-processing options in detail. **[16]**
- Q6)** What are the various options available for residue processing in crude refining? Describe FCCU in brief. **[18]**
- Q7)** Explain in detail how elemental sulphur is produced from waste streams in modern refineries. **[16]**

P.T.O.

Q8) Write notes (any two) :

- a) LOBS. **[8]**
- b) Hydrogen Management. **[8]**
- c) Delayed Coker. **[8]**



Total No. of Questions : 8]

SEAT No.:

P1764

[Total No. of Pages : 2

[4164]-223
B.E. (Petrochemical)
REACTION ENGINEERING - II
(2003 Pattern) (Sem. - I)

Time : 3 Hours]

[Max. Marks : 100

Instructions to the candidates:

- 1) Attempt any three questions from each section.*
- 2) Answer to the two sections should be written in two separate answer books.*
- 3) Figures to the right indicate full marks.*
- 4) Assume suitable data wherever necessary.*
- 5) Use of steam tables and electronic calculator is allowed.*

SECTION - I

- Q1)** a) Explain Langmuir-Hinshelwood kinetic mechanism. **[6]**
b) Write reaction statement for toluene dismutation process which yields xylene and benzene from toluene over a solid catalyst. Suggest an appropriate kinetic equation assuming surface reaction to be rate controlling. **[10]**
- Q2)** a) Comment on the relationship between effectiveness factor and Thiele Modulus. Explain the effect of pellet size and speed of surface reaction on effective utilization of a catalyst surface area. **[6]**
b) We want to design a packed bed reactor filled with 2.5-cm porous catalyst particles (catalyst density is 2500kg/m³ and effective diffusivity is 2.1×10^{-6} m²/m cat. s) to treat 3m³/s of feed gas (1/3 A, 1/3 B, 1/3 inert) at 350C and 5 bar to 95% conversion of A. Experiments with fine catalyst particles, which are free from diffusional resistance, show that the gas phase reaction $A + B \rightarrow R + S$ is second order with rate constant given as 0.05m⁶/mol.kg.s. Calculate the mass of catalyst needed. **[12]**
- Q3)** a) Calculate external surface area in sq m per gm of 5 micron sized non-porous catalyst. (Assume solid catalyst's Sp. Gr. as 2.8) what size will be needed if the external surface is to be 150 sq m per gm. **[4]**

P.T.O.

- b) In an experiment to determine pore volume and porosity of a catalyst per unit weight, following data was obtained. For 102gm of catalyst sample, volume of helium displaced was 45cm^3 whereas volume of mercury displaced was 89cm^3 . Calculate solid density, pore volume per gm and porosity of the catalyst per gm weight of catalyst. [6]
- c) Discuss BET method for measurement of catalyst surface area. [6]
- Q4)** a) Discuss the effects of pore diffusion on kinetic studies at laboratory level. What precautions are needed before undertaking these studies? [8]
- b) Give an account of pertinent catalytic reactions, catalysts used and reactors employed in catforming, fluid cracking and hydrocracking. [8]

SECTION - II

- Q5)** Gas A and liquid B react in a mechanically agitated contactor. The reaction is slow, second order and occurs in bulk liquid, Set up a mathematical model for the steady state operation of this reactor. State all your assumptions clearly. Check if it is analytically solvable for exit concentrations of A and B? If yes, provide the solution in terms of the other operating parameters. [16]
- Q6)** An acidic impurity A in a gaseous stream is to be removed so as to reduce its partial pressure from 150 Pa to 100 Pa (total pressure is 100 kPa) by reacting it with a base B dissolved in water in a packed tower operated in a counter-current manner. Overall gas side mass transfer coefficient is $0.007\text{ mol/hr.m}^3\text{.Pa}$. Gas side resistance to mass transport in absence of the reaction is 5% whereas the liquid film contributes the remaining 95% resistance. Henry's constant is $10\text{ Pa.m}^3\text{/mol}$. L/G ratio is 8 mol/mol. Calculate minimum concentration of B needed at the top of the tower to ensure minimum height of the tower. Also calculate this minimum height. [18]
- Q7)** a) Derive time-conversion relationship for a cylindrical particle reacting with a gas in a uniform atmosphere. Assume the diffusion to gas transport through the product layer formed to be controlling the overall rate. [10]
- b) Spherical particle of ZnS with initial diameter of 1.5cm is subjected to roasting in presence of air. Roasting reaction yields SO_2 as also the layer of ZnO. Molar density of solid may be assumed to be 0.045 mol/cm^3 . Diffusivity of gas through the product layer is $0.08\text{cm}^2\text{/s}$. Calculate the time required to convert the particle by 95%. [6]
- Q8)** a) Explain the mechanisms of catalyst deactivation. [8]
- b) Define Hatta Number. Discuss its significance in the choice and design of g-L reactors. [8]



Total No. of Questions : 12]

SEAT No. :

P1775

[Total No. of Pages : 3

[4164]-41
B.E. (Mech./Mech. S/W)
INDUSTRIAL HYDRAULICS & PNEUMATICS
(2003 Pattern) (Sem. - I)

Time :3 Hours]

[Max. Marks :100

Instructions to the candidates:

- 1) *All questions are compulsory.*
- 2) *Answers to the two sections should be written in separate books.*
- 3) *Figures to the right indicate full marks.*
- 4) *Use of logarithmic tables slide rule, Mollier charts, electronic pocket calculator and steam tables is allowed.*
- 5) *Assume suitable data, if necessary.*

SECTION - I

- Q1)** a) Discuss any six important properties of hydraulic fluid. [6]
b) What are the different types of seals provided in hydraulic components? [6]
c) What are different locations of seals in hydraulic circuit. [4]

OR

- Q2)** a) What are the different materials used for seals? Compare their characteristics. [8]
b) What are the factors considered while selecting hydraulic fluids? [8]
- Q3)** a) Explain with a neat sketch the working of a fixed delivery axial piston pump. [10]
b) What are the different accessories used in hydraulic systems. What are their functions. [6]

OR

- Q4)** a) Explain the different types of accumulators used in hydraulic circuit. [8]
b) Draw a neat sketch and explain working of a typical Vane pump. [8]

P.T.O.

- Q5)** a) State the advantages and disadvantages of meter-in circuit. Draw sketch of circuit. [8]
b) Explain with neat sketch working of a counter balance valve and draw a circuit showing its application. [10]

OR

- Q6)** a) Classify direction control valves & differentiate open centre and close centre valve position in direction control valves. [8]
b) Explain the counter balance valve with a neat sketch, its working with a typical application. [10]

SECTION - II

- Q7)** a) What are the different cylinder mountings? [4]
b) Draw a typical circuit for motor braking? [4]
c) Draw a typical synchronization circuit and explain its working. [8]

OR

- Q8)** a) What is the purpose of providing cushioning in cylinders? With the help of a neat sketch explain how it is achieved? [8]
b) Draw a neat sketch and explain working of a pressure regulator. [8]
- Q9)** a) Compare hydraulic systems with pneumatic systems. [6]
b) What is the purpose of providing Filter, Regulator and lubricator in pneumatics. [6]
c) How is the speed of actuators controlled in pneumatics? [6]

OR

- Q10)** a) Draw neat sketch & explain working of 3 by 2 direction control valve used in pneumatics? What are the different methods of operating these valves? [8]
b) Draw typical circuits of different speed regulating methods used in pneumatic circuits. [10]
- Q11)** a) Explain with a neat the working of 'AND' valve with a typical application. [8]
b) Explain with a neat sketch the working of OR valve with typical application. [8]

OR

- Q12)** a) A double acting hydraulic cylinder has a reciprocating motion. The forward motion is obtained using a regenerative circuit. The load during this forward stroke is 10 kN. The total stroke of 1 m is to be completed in about 11 seconds. Draw a circuit to achieve above. **[8]**
- b) Explain with a neat sketch the working of 4 way 2 position lever operated direction control valve. **[8]**

* * *

Total No. of Questions : 12]

SEAT No. :

P1780

[Total No. of Pages : 4

[4164] - 59

B.E. (Production)

MATERIALS AND FINANCIAL MANAGEMENT

(2003 Pattern) (Sem. - II)

Time :3 Hours]

[Max. Marks :100

Instructions to the candidates:

- 1) *Answer three questions from each section.*
- 2) *Answers to the two sections should be written in separate books.*
- 3) *Neat diagrams must be drawn wherever necessary.*
- 4) *Figures to the right indicate full marks.*
- 5) *Use of logarithmic tables, slide rules, Mollier charts, electronic pocket calculator and steam table is allowed.*
- 6) *Assume suitable data, if necessary.*

SECTION - I

Unit - I

- Q1)** a) Define service level. Derive an equation to determine the optimum service level. **[8]**
- b) Daily demand of a product is 10 units with a standard deviation of 3 units. The review period is 30 days, and the lead time is 14 days. Management has set a policy of satisfying 98% of demand from items in stock. At the beginning of this review period, there are 150 units in inventory. How many units should be ordered? The z value for $P = 0.98$ is 2.05 **[8]**

OR

- Q2)** a) Explain the importance of Materials management functions in manufacturing as well as in service organisation. What are the various tools and techniques used to achieve this function? **[8]**

P.T.O.

- b) Drugs Online (DO) is an online retailer of prescription drugs. Vitamins represent a significant percentage of its sales. Demand for vitamins is 10000 bottles per month. DO incurs a fixed order placement, transportation, and receiving cost of Rs. 1000 each time an order for vitamin is placed with manufacturer. DO incur a holding cost of 20 percent. The price charged by the manufacturer follows the unit discount pricing schedule is shown below. Evaluate the number of bottles that the DO manager should order in each lot. [8]

Quantity ordered	Unit Price (In Rs.)
0 - 4999	30.00
5000 - 9999	28.50
10000 and above	27.00

Unit - II

- Q3)** a) Describe the fundamental similarities and differences between procurement, manufacturing support, and physical distribution performance cycles as they relate to logistical control. [8]
- b) Explain how reduction in lead time can help a supply chain to reduce safety inventory without hurting product availability. [8]

OR

- Q4)** a) Discuss uncertainty as it relates to overall logistical performance cycle. How can order cycle variance be controlled? [8]
- b) Why might it be economically justified to have multiple instorage handling of product in a warehouse? [8]

Unit - III

- Q5)** a) Explain Import procedure in detail. What are the various documents needed during Importing. [10]
- b) Explain the importance of the Waste management in manufacturing industry. [8]

OR

- Q6)** Write short notes on: [18]
- a) EXIM Policy.
- b) Value Engineering.
- c) E-Procurement.

SECTION - II

Unit - IV

- Q7)** a) Explain the sources of finance. What are the financial functions to be performed for successful financial management? [8]
b) What are the different approaches in determination of working capital need? [8]

OR

- Q8)** a) The ABC Company's financial statements contain following information as on 31.03.2012. Calculate and interpret the following: [8]
i) Quick Ratio
ii) Working Capital turnover ratio
iii) Operating Ratio

Particulars	Rs.
Current liabilities	6,40,000
Total Current Assets	25,88,000
Inventories	16,00,000
Cost of goods sold	28,00,000
Net sales	40,00,000
Operating Expenses	1,60,000

- b) What are the determinants of working capital? Explain in detail. [8]

Unit - V

- Q9)** a) From the records of ABC Ltd, the following information are available: [8]

i) Raw Materials

Opening Stock = Rs. 20,000

Closing Stock = Rs. 30,000

Total purchase during the year - 1,70,000

ii) Finished goods

Opening Stock = Rs. 10,000

Closing Stock = Rs. 15,000

Sales - Rs. 4,89,500

iii) Direct Wages = Rs. 1,20,000

iv) Factory Expenses = Rs. 1,20,000

v) Non Manufacturing Expenses = Rs. 50,000

Find out what price should be quoted for a product involving an expenditure of Rs. 20,000 in material and Rs. 30,000 in wages.

- b) Explain different methods of Pricing (Valuation) of the material. [8]

OR

- Q10)a)** Explain job costing and process costing in detail. States the merits and demerits of each. [8]
- b) A Rs. 2,00,000 machine is to replaced in 20 years. Find the annual investment that must be made at 10% to provide the sum to replace the machine, using [8]
- i) sinking fund factor. ii) capital recovery factor.

Unit - VI

- Q11)a)** Define overhead. What do you mean by term under/over absorption of production overheads? How does it arise? How does it treated in cost accounts? [8]
- b) From the following information, select the best Project using Payback Period Method. [10]

	Project A	Project B	Project C
Cost (Rs.)	3,40,000	3,80,000	3,50,000
Life	12 years	11 years	13 years
Scrap value (Rs.)	20,000	18,000	30,000
Annual Earnings	26,000	31,000	28,000

OR

- Q12)a)** What preliminaries have to be complied with before introducing a technique of standard costing? [8]
- b) A company has investment opportunity costing Rs. 40,000 with following expected net cash flow i.e. after taxes and before depreciation: [10]

Year	Net cash flow Rs.
1	7,000
2	8,000
3	8,000
4	9,000
5	10,000
6	10,000
7	12,000

Using 10% as the cost of capital determine Net present value at 10% Discount factor.



Total No. of Questions : 12]

SEAT No. :

P1808

[Total No. of Pages : 3

[4164]-36
B.E. (Mechanical)
ENERGY MANAGEMENT
(2003 Pattern) (Elective - II) (Sem. - II)

Time :3 Hours]

[Max. Marks :100

Instructions to the candidates:

- 1) *Answer three questions from each section.*
- 2) *Answer of two sections should be written in separate answer books.*
- 3) *Neat diagram must be drawn whenever necessary.*
- 4) *Figures to the right indicate full marks.*
- 5) *Use of calculator Log tables and electronic calculator is allowed.*

SECTION - I

- Q1)** a) Explain the various types of sources of energy in world energy market. [8]
b) What are the different strategies to be considered for long term energy management in India. [8]

OR

- Q2)** a) Explain the importance of energy management program in industry. [8]
b) What are the energy consumption patterns of industry, agriculture and residential sector in India. [8]

- Q3)** a) What is meant by “Bench Marking”? Explain present value concept. [8]
b) Write in short the steps involved in energy audit of any industry. [8]

OR

- Q4)** Write a short note on (Any two) : [16]
a) Discount Rate and internal rate of return.
b) Energy audit of air compressor.
c) Energy analysis of furnace system.
d) Instruments used in energy audit.

P.T.O.

- Q5)** a) Discuss the factors affecting on performance and energy efficiency in refrigeration and air conditioning plant. [6]
- b) Discuss the following terms for the efficient operation of compressed air system. [6]
- i) Quality of air.
 - ii) Capacity control of compressor.
 - iii) Piping layout.
- c) State the energy saving opportunities, in steam distribution system. [6]

OR

- Q6)** a) State the various energy efficiency opportunities in boiler system. [6]
- b) Explain the following terms : [6]
- i) Direct and indirect method to increases the efficiency of boilers.
 - ii) Evaporation ratio and boiler efficiency.
 - iii) Excess air and flue gas monitoring.
- c) List the factors affecting on efficiency of the compressor. [6]

SECTION - II

- Q7)** a) Two lamps are to be compared :
- i) Cost of first lamp is Rs. 1 and it takes 100 watts.
 - ii) Cost of second lamp is Rs. 4 and it takes 60 watts.
- Both the lamps are of same candlepower and each has the useful life of 100 hr, which lamp will prove economical if the energy is charged at Rs. 70 per kW of maximum demand per year plus Rs. 0.05 per kWh?[8]
- b) Explain the difference between fan blower and compressor. Also explain how the flow is measured by using pitot tube. [8]

OR

- Q8)** a) Discuss good practices of energy conservation in lighting system. [8]
- b) What are benefits of power factor improvement. [8]
- Q9)** a) Explain the waste heat recovery systems used in boiler and explain how efficiency of the plant increases. [8]
- b) What are energy saving opportunities in common Indian households? Elaborate with example and percentage of possible saving in energy bill.[8]

OR

- Q10)** a) Draw and explain the typical gas turbine cycle cogeneration system. [8]
b) Explain the benefits of insulation. How they are classified? Explain the economic thickness of insulation on pipe. [8]

- Q11)** a) Explain energy conservation opportunities in thermal power plant. [6]
b) List the energy saving opportunities in pumping station. [6]
c) What is refractory? How these are classified? State in brief the selection criteria. [6]

OR

- Q12)** Write a short note on any three : [18]
a) Different heat losses in furnace.
b) Energy conservation in pumps.
c) Variable speed drive.
d) Waste heat recovery.

* * *

Total No. of Questions : 8]

SEAT No.:

P2053

[Total No. of Pages : 2

[4164]-15
B.E. (Civil)
ADVANCED STRUCTURAL DESIGN
(2003 Pattern) (Elective - II) (Sem. - II)

Time : 3 Hours]

[Max. Marks : 100

Instructions to the candidates:

- 1) *Attempt Q. 1 or Q. 2, Q. 3 or Q. 4 from section-I and Q. 5 or Q. 6, Q. 7 or Q. 8 from section-II.*
- 2) *Answers to the two sections should be written in separate answer books.*
- 3) *Neat diagram must be drawn wherever necessary.*
- 4) *Figure to the right indicates full marks.*
- 5) *Assume suitable data, if necessary.*
- 6) *Use of cell phone is prohibited in the examination hall.*
- 7) *Use of electronic pocket calculator, steel table and relevant IS code is allowed.*

SECTION - I

Q1) Two channel sections without bent lips 200 mm × 50 mm and 2.5 mm thick are connected with webs to act as beam. The effective span of a simply supported beam is 6 m. The beam is laterally supported throughout its length. Determine the maximum uniformly distributed load inclusive of self weight which can be supported by the beam. Assume $f_y = 232 \text{ N/mm}^2$ and $I_x = 2 \times 390.307 \times 10^4 \text{ mm}^4$. **[25]**

OR

Q2) Select suitable configuration of the truss and determine the maximum compressive and tensile force in the leg at the base for a 40 m microwave antenna tower is to be built near Pune. The terrain at the location is a level ground. It has to carry a 2.4 m diameter hemispherical antenna disc at the top. **[25]**

- a) Width at the top of tower = 3 m
- b) Width of tower at bottom = 6 m
- c) Weight of platform at top = 0.75 kN/m²
- d) Weight of railing at top = 0.25 kN/m
- e) Weight of ladder and cage = 0.50 kN/m
- f) Weight of antenna disc and fixture = 10 kN
- g) Self weight of truss = 6 kN/m
- h) Terrain category II and class of building B.

P.T.O.

Q3) Design an open web (castellated beam) for a span of 15m. The dead load coming on roofing is 1.2 kN/m^2 and live load on the roof is 1.6 kN/m^2 . Calculate the spacing of the beam and check for shear and deflection. Adopt suitable pattern of castellation and adjust the section such that overall depth of section should not exceed 900 mm. Assume $f_y = 250 \text{ MPa}$. [25]

OR

Q4) Design a hoarding board of size $4 \text{ m} \times 8 \text{ m}$, with minimum height from ground = 3.2m . Take basic wind velocity in the area as 39 m/s. Also design the anchor block. [25]

SECTION - II

Q5) A simply supported rectangular RC grid floor is $12 \text{ m} \times 09 \text{ m}$ with centre to centre spacing of grid 1.5 m in both the directions. Take live load = 3 kN/m^2 and floor finish = 1.0 kN/m^2 . Use M_{25} grade of concrete and Fe_{415} grade of steel. Draw the details of the reinforcement in beams and slab. [25]

OR

Q6) Design simply supported circular slab of 6 m diameter, subjected to service live load of 4.0 kN/m^2 and floor finish of 1 kN/m^2 . Use M_{25} grade of concrete and Fe_{500} grade of steel. Draw the reinforcement details. [25]

Q7) Design an interior panel of size $5 \text{ m} \times 5 \text{ m}$ of a flat slab with suitable drop to support a live load of 4000 N/m^2 . The slab is provided with floor finish of 1000 N/m^2 . The floor system is supported by columns of size $450 \text{ mm} \times 450 \text{ mm}$. Floor to floor distance is 4 m. Use M_{20} grade of concrete and Fe_{500} grade of steel. Draw the reinforcement details. [25]

OR

Q8) Design a counter fort retaining wall for the following data.

Height of wall above ground level = 6.8 m

Safe bearing capacity of soil = 200 kN/m^2

Angle of repose = 30°

Unit weight of soil = 16000 N/m^3

Spacing of counter fort = 3 m

Coefficient of friction between soil and concrete = 0.35

Use M_{25} grade of concrete and Fe_{415} grade of steel. Draw the reinforcement details. [25]



Total No. of Questions : 12]

SEAT No. :

P2054

[Total No. of Pages : 3

[4164]-280-B
B.E. (I.T.)
REAL TIME SYSTEMS
(2003 Pattern) (Elective - II) (Sem. II)

Time :3 Hours]

[Max. Marks :100

Instructions to the candidates:

- 1) *Answers to the TWO sections should be written in separate books.*
- 2) *Use of logarithmic tables, slide rules and electronic pocket calculator is allowed.*
- 3) *Neat diagram must be drawn wherever necessary.*
- 4) *Figures to the right indicate full marks.*
- 5) *Assume suitable data, if necessary.*

SECTION - I

- Q1)** a) Explain the resource management issues in RTS in brief. **[8]**
b) Discuss some common important misconception about real time system and how they are interpreted in RTS in brief. **[8]**

OR

- Q2)** a) Give classification of Real time Systems and explain with suitable examples wherever necessary. **[8]**
b) Explain the difference between real time program and non-real time program. Why real time programs are more difficult to verify? **[8]**
- Q3)** a) Discuss the timing and consistency issues in real time database. Explain the need for response time predictability. **[8]**
b) Describe MOS (Myopic Offline Scheduling Algorithm). Give examples of RTS where MOS can be safely used. **[8]**

OR

- Q4)** a) List all assumptions for uni-processor scheduling algorithms. What are necessary and specific conditions for EDF schedule-ability. **[8]**

P.T.O.

- b) Run a RM schedule-ability check for the set of following tasks and show the schedulable tasks. [8]

Ti	Ei	Pi
1	25	100
2	75	150
3	100	210
4	25	400

- Q5)** a) What are data typing requirements of programming languages for RTS? [8]
b) Explain in brief desired properties of exception handling and overloading in programming languages for RTS. [10]

OR

- Q6)** a) What is MADARTS? Describe the features and applications of MDARTS. [8]
b) Explain the working of AED (Adaptive Dead line First) for handling transaction priorities in RTS. [10]

SECTION - II

- Q7)** a) Explain the following terms with respect to Real Time Network topology. [10]
i) Diameter.
ii) Node degree.
iii) Fault tolerance.
b) Explain the Window protocol a contention based protocol for message transmission in RTS communication system. [8]

OR

- Q8)** a) What are the overheads incurred by Token based protocols? Discuss in brief. [8]
b) Describe Stop-and-Go protocol. What are the packet priority and eligibility conditions? [10]

- Q9)** a) Discuss the following OS issues with respect to RTOS. [8]
i) Task assignment and scheduling.
ii) Failure management and recovery techniques.
b) Describe interrupt level, periodic level task priority structure handled in RTOS. [8]

OR

Q10) a) Differentiate between Real Time Multi-user and Multi-Tasking Operating systems. [8]

b) Describe main functionality of any one commercial RTOS. [8]

Q11) a) How the redundancy management is used for fault tolerance in RTS? List the types of redundancy with brief description. [8]

b) Discuss fault types in RTS in brief. [8]

OR

Q12) a) Software redundancy in terms of fault tolerance in RTS. [8]

b) Explain following terms with respect to integrated failure handling in Time Systems. [8]

i) Timing information.

ii) State transition rate.

* * *