

Biology

1. If an interphase cell is treated with cyanide (a metabolic poison), the cell does not divide by mitosis. However, if cyanide is added right after mitosis has started, the same cell completes mitosis. Which of the following explains this observation?
 - A. Metabolic activity ceases during mitosis
 - B. Cell division does not require metabolic activity
 - C. Energy required for mitosis is produced and stored in the cell during interphase
 - D. Mitotic cells make factors that make them resistant to cyanide
2. The symplast pathway is most easily disrupted when
 - A. Water transport channels in the plasma membrane of the root hair cells malfunction
 - B. Water transport channels in the plasma membrane of the root cortex malfunction
 - C. Water transport channels in the plasma membrane of the root endodermis malfunction
 - D. Water transport channels in the plasma membrane of the guard cells malfunction
3. Paleontological studies use fossil pollen because
 - A. Pollen retains viability for long periods of time unlike male gametes in animals
 - B. The intine of pollen is very hard and stable and can be used in rescuing plant populations on a decline
 - C. The exine of pollen retains its structure for long periods of time
 - D. Soil pollen banks, unlike soil seed banks, stay dormant for long periods of time
4. Which of the following is not an assumption of the Hardy-Weinberg principle?
 - A. Mating is random in the population
 - B. There are no mutations
 - C. All individuals have an equal opportunity to survive and reproduce
 - D. Immigration and emigration occurs in the population
5. The lens of many vertebrate eyes is a crystallized form of a protein that also functions in digestion as a metabolic enzyme. This shows that
 - A. Vision and digestion co-evolved
 - B. Digestion necessarily evolved prior to vision since it is a more basic function
 - C. Evolution is opportunistic
 - D. Vision and digestion evolved around the same time
6. On which segment of the human chromosome is the enzyme Reverse Transcriptase located?
 - A. Centromere
 - B. Telomere
 - C. Kinetochore

- D. Satellite
7. Muscle X and muscle Y are of the same size, but muscle X is capable of much finer control than muscle Y. Which of the following is likely to be true of muscle X?
- A. It is controlled by more neurons than muscle Y
 - B. It contains fewer motor units than muscle Y
 - C. It is controlled by fewer neurons than muscle Y
 - D. Each of its motor units consists of more cells than the motor units of muscle Y
8. A National Park associated with rhinoceros is
- A. Kaziranga
 - B. Corbett
 - C. Ranthambore
 - D. Valley of Flowers
9. During HIV infection
- A. Number of helper T-lymphocytes increase
 - B. Number of helper T-lymphocytes decrease
 - C. Number of red blood cells increase
 - D. Number of red blood cells decrease
10. If the blood groups of the father and mother are AB and B respectively, then which one of the following statements is true with respect to their children's blood group?
- A. Blood group is either A or B
 - B. Blood group is either B or AB
 - C. Blood group is AB only
 - D. Blood group can be A or B or AB
11. The sequence of DNA is 5'-ATGGTTCATC-3'. What is the sequence of the complimentary RNA strand?
- A. 5'-TACCAAGGTAG-3'
 - B. 3'-TACCAAGGTAG-5'
 - C. 3'-UACCAAGGUAG-5'
 - D. 5'-UACCAAGGUAG-3'
12. Which one of the following statements is correct with respect to Biochemical Oxygen Demand (BOD)?
- A. Secondary treatment of effluent decreases the BOD
 - B. Secondary treatment of effluent increases the BOD
 - C. Secondary treatment of effluent does not change the BOD
 - D. Secondary treatment of effluent first increases and then decreases the BOD

13. Which of the following is a general nature of plant-pollinator interactions?
- A. Tight one to one co-evolutionary partnership
 - B. A plant species is pollinated by a few pollinator species
 - C. Plants rely on deceit to achieve pollination by pollinator species
 - D. Most pollinators benefit the plant by providing pollinator services, but disadvantage the plant at the same time by laying eggs into the flower and thereby negatively affects fruit formation
14. Sickle cell anemia is a disease resulting from altered haemoglobin structure. This alteration is because of the replacement of a glutamic acid with valine. Identify the protein structure level where this change has been made
- A. Primary
 - B. Secondary
 - C. Tertiary
 - D. Quaternary
15. Which of the following life history adaptations is least likely when predation pressure, on a fish species that grows in size continuously throughout its lifespan, is concentrated on the larger individuals
- A. Allocate more resources preferentially to early reproduction than to growth
 - B. Allocate more resources preferentially to growth than to early reproduction
 - C. Sexual maturity at an early age
 - D. Produce more offspring in very few reproductive seasons

Chemistry

16. What is the potential of a cell containing two hydrogen electrodes, in which the anode is in contact with 10^{-5}M HCl and the cathode is in contact with 1000 times the concentration of HCl as that of the anode?
- A. 0.36 V. B. 0.18 V. C. -0.36 V. D. -0.18 V.
17. Phosphorus pentoxide, P_4O_{10} , has each phosphorus linked to:
- A. 5 oxygen atoms with $P - P$ bonds.
B. 5 oxygen atoms.
C. 4 oxygen atoms with $P - P$ bonds.
D. 4 oxygen atoms.
18. The radius of an atom of He is 0.05 nm. Assuming that one mole of a gas occupies 22.4 litres at STP, the fraction of the volume occupied by the atoms in a mole of He gas at STP is:
- A. 1.4×10^{-4} . B. 1.4×10^{-5} . C. 7.1×10^{-4} . D. 7.1×10^{-5} .
19. The number of degenerate orbitals present in an energy level of a H -atom characterized by $E = -\frac{R}{16}$ where R is the Rydberg constant is:
- A. 16. B. 9. C. 4. D. 1.
20. Formation of ammonia in Haber's process, $\text{N}_2 + 3\text{H}_2 \rightarrow 2\text{NH}_3$ ($\Delta H = -ve$) can be increased by:
- A. increase in temperature and pressure.
B. increase in temperature.
C. increase in the concentration of ammonia.
D. increase in pressure.
21. Choose the correct ordering for the dipole moments of the following molecules:
- A. $\text{CO}_2 \leq \text{BF}_3 < \text{H}_2\text{O} < \text{H}_2\text{S}$.
B. $\text{BF}_3 < \text{CO}_2 < \text{H}_2\text{S} < \text{H}_2\text{O}$.
C. $\text{CO}_2 = \text{BF}_3 < \text{H}_2\text{S} < \text{H}_2\text{O}$.
D. $\text{CO}_2 < \text{BF}_3 < \text{H}_2\text{S} < \text{H}_2\text{O}$.
22. Which among the following complexes of Mn given below has the spin only magnetic moment (μ_s) value of 5.9 BM?
- A. $[\text{Mn}(\text{CN})_6]^{4-}$
B. $[\text{Mn}(\text{Br})_4]^{2-}$
C. $[\text{Mn}(\text{en})_3]^{2+}$; $\text{en} = \text{ethylenediamine}$
D. $\text{Mn}_2(\text{CO})_{10}$
23. Schottky as well as Frenkel defects are observed in:

- A. NaCl. B. ZnS. C. AgBr. D. KCl.

24. A black mineral *A* on heating in air gives a gas *B*. The mineral *A* on reaction with H_2SO_4 gives a gas *C* and a compound *D*. Bubbling *C* into an aqueous solution of *B* gives white turbidity. The aqueous solution of compound *D*, on exposure to air, with NH_4SCN gives a red compound *E*. The compounds *A* and *E* respectively, are:

- A. PbS and $Pb(SCN)_2$.
 B. NiS and $Ni(SCN)_2$.
 C. FeS and $Fe(SCN)_3$.
 D. CoS and $Co(SCN)_2$.

25. Using the diagram given below, the relation between k_1 and k_2 for the reaction $A \rightarrow C$ is:

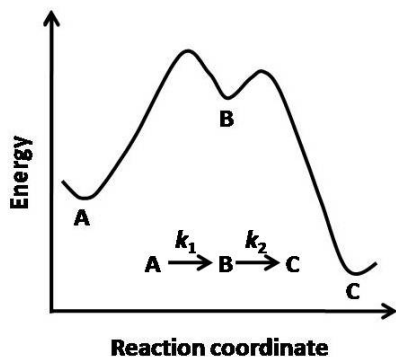

- A. $k_1 = k_2$. B. $k_2 \ll k_1$. C. $k_1 \leq k_2$. D. $k_1 \ll k_2$.

26. The structure of IV in the following sequence is:

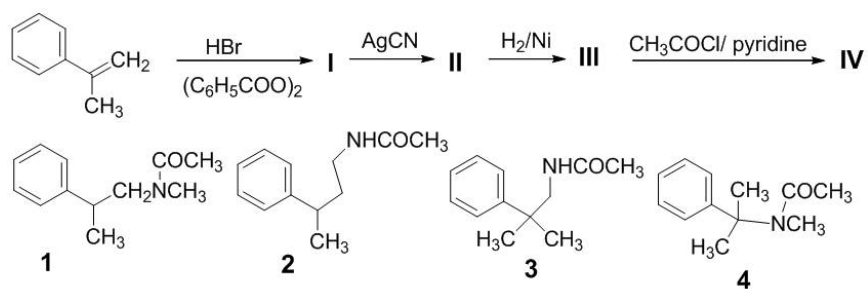

- A. 1. B. 2. C. 3. D. 4.

27. Arrange the following chloroarenes in increasing order of their reactivity in nucleophilic substitution to form their corresponding phenols.

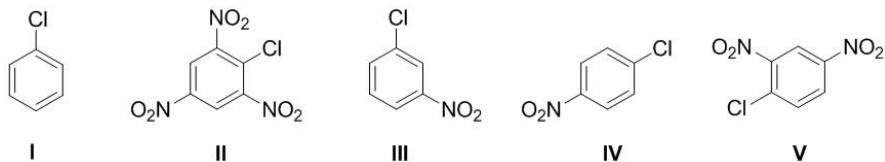

- A. II < V < III ~ IV < I.
 B. II < V < III < I < IV.
 C. I ~ III < IV < V < II.
 D. I < IV < III < V < II.
28. Which of the following methods is suitable for the preparation of 1,3,5-tribromobenzene from benzene?

- A. (i) $\text{AlBr}_3/\text{Br}_2$, light (ii) separation of isomers.
 B. (i) $\text{HNO}_3/\text{H}_2\text{SO}_4$ (ii) Sn/HCl (iii) Br_2 (iv) NaNO_2/HCl (v) $\text{C}_2\text{H}_5\text{OH}, \Delta$.
 C. (i) $\text{HNO}_3/\text{H}_2\text{SO}_4$ (ii) NaBH_4 (iii) $\text{Br}_2/\text{CH}_3\text{COOH}$ (iv) NaNO_2/HCl (v) H_3PO_2 .
 D. (i) $\text{HNO}_3/\text{H}_2\text{SO}_4$ (ii) H_2/Pd (iii) NaNO_2/HCl (iv) CuBr/HBr .
29. The order of reactivity of the following ketones towards nucleophilic addition of water is:

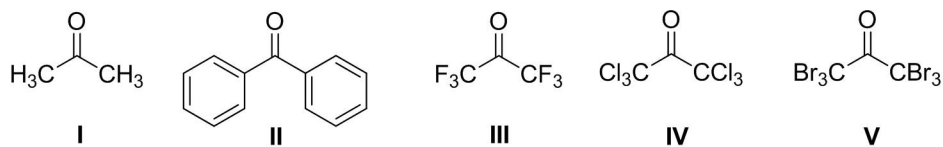

- A. III < IV < V < I < II.
 B. I < V < IV < III < II.
 C. I < III < IV < V < II.
 D. II < I < V < IV < III.
30. Which among the solutions given below will not show a change in pH on dilution? (I). 0.1 M $\text{NH}_4\text{COOCH}_3$, (II). 0.1 M NaCl , (III). 0.1 M NH_4OH , (IV). 0.01 M H_2SO_4 .
- A. I and II. B. I, II and IV. C. I and III. D. III and IV.

Mathematics

31. If $I_m = \int_0^{\pi/4} (\tan x)^m dx$, then $I_3 + I_5 + I_7 + I_9$ equals:

- A. $\frac{3}{8}$. B. $\frac{3}{7}$. C. $\frac{2}{5}$. D. $\frac{4}{9}$.

32. Which is the largest number in the following sequence?

$$1^{\frac{1}{\sqrt{1}}}, 3^{\frac{1}{\sqrt{3}}}, 5^{\frac{1}{\sqrt{5}}}, \dots, (2n+1)^{\frac{1}{\sqrt{2n+1}}}, \dots$$

- A. $3^{\frac{1}{\sqrt{3}}}$.
B. $5^{\frac{1}{\sqrt{5}}}$.
C. $7^{\frac{1}{\sqrt{7}}}$.
D. The sequence is unbounded.

33. Assuming that the interchange of limit and integration is permissible, the value of

$$\lim_{n \rightarrow \infty} \int_0^1 \frac{nx^{n-1}}{1+x} dx \quad ; \quad 0 < x < 1$$

is:

- A. 0. B. $\frac{1}{2}$. C. 1. D. ∞ .

34. Let $f : \mathbb{R} \rightarrow \mathbb{R}$ be a function such that $|f(x) - f(y)| \leq 6|x - y|^2$ for all $x, y \in \mathbb{R}$. If $f(3) = 6$ then $f(6)$ equals:

- A. 6. B. 9. C. 12. D. 18.

35. Let A_n be the area bounded by the curves $y = x$ and $y = nx^2$ in the first quadrant. Then the value of $\sum_{n=1}^5 \frac{1}{A_n}$ is:

- A. 110. B. 220. C. 330. D. 440.

36. In how many ways can four distinguishable pieces be placed on an 8×8 chessboard so that no two pieces are in the same row or column?

- A. $\frac{8!}{4!}$. B. $\frac{(8!)^2}{(4!)^2}$. C. $\frac{(8!)}{(4!)^2}$. D. $\frac{(8!)^2}{(4!)^2}$.

37. A and B are playing a game by alternately rolling a die, with A starting first. Each player's score is the number obtained on his last roll. The game ends when the sum of scores of the two players is 7, and the last player to roll the die wins. What is the probability that A wins the game?

- A. $\frac{11}{36}$. B. $\frac{5}{11}$. C. $\frac{17}{36}$. D. $\frac{6}{11}$.

38. The binomial coefficients $\binom{n}{r}, \binom{n}{r+1}, \binom{n}{r+2}$; $0 \leq r \leq n-2$:

- A. Can be in A.P. or in G.P.
 B. Can be in A.P. but never in G.P.
 C. Can be in G.P. but never in A.P.
 D. Can never be in A.P. or G.P.

39. The sum of the infinite series $\cot^{-1} 2 + \cot^{-1} 8 + \cot^{-1} 18 + \dots + \cot^{-1} (2n^2) + \dots$ is:

- A. $\frac{\pi}{3}$. B. $\frac{\pi}{4}$. C. $\frac{\pi}{6}$. D. $\frac{\pi}{8}$.

40. The number of integer values of k for which the equation $7\cos \theta + 5\sin \theta = 2k + 1$ has real solutions is:

- A. 6. B. 8. C. 10. D. 12.

41. The complex solutions of $(z + i)^{2011} = z^{2011}$ lie on:

- A. A circle.
 B. An ellipse.
 C. A hyperbola.
 D. A straight line.

42. How many 2×2 matrices A satisfy both $A^3 = I_2$ and $A^2 = A^t$, where I_2 denotes the 2×2 identity matrix and A^t denotes the transpose of A ?

- A. 0. B. 1. C. 2. D. 3.

43. Let C be the circle that touches the X -axis and whose centre coincides with the circumcentre of the triangle defined by $4|x| + 3y = 12$; $y \geq 0$. How many points with both co-ordinates integers are there in the interior of C ?

- A. 0. B. 1. C. 2. D. 3.

44. Let P and Q be the centres of the circles that pass through $(0, 2)$ and $(0, 8)$ and touch the X -axis. Then the equation of the ellipse with P and Q as foci and touching the X -axis is:

- A. $\frac{x^2}{41} + \frac{(y-5)^2}{25} = 1$.
 B. $\frac{x^2}{16} + \frac{(y-5)^2}{25} = 1$.
 C. $\frac{(x-5)^2}{41} + \frac{y^2}{25} = 1$.
 D. $\frac{(x-5)^2}{16} + \frac{y^2}{25} = 1$.

45. Let $f : \mathbb{R} \rightarrow \mathbb{R}$ be a function such that $f(x + y) + f(x - y) = f(xy)$ for all $x, y \in \mathbb{R}$. Then f is:
- A. Strictly increasing.
 - B. Strictly decreasing.
 - C. Identically zero.
 - D. Constant but not necessarily zero.

Physics

46. A physical quantity f depends on the dimensionful quantities x and y as follows:

$$f = Ax + B \exp(cy) .$$

Which of the following *do not* have the same dimensions:

- A. f and B
 - B. c and y^{-1}
 - C. x and B/A
 - D. x and A
47. The period of oscillation of a simple pendulum of length L suspended from the roof of a rocket accelerating upwards with a constant acceleration (g) is given by:
- A. ∞
 - B. 0
 - C. $2\pi \sqrt{\frac{L}{2g}}$
 - D. $2\pi \sqrt{\frac{L}{g}}$
48. The moment of inertia of a uniform solid disc of mass M and radius R about an axis normal to the disk and passing through its center is $\frac{MR^2}{2}$. What is the moment of inertia of the same disc about an axis lying in its plane and tangent to it (as shown in the figure)?

- A. $\frac{MR^2}{4}$
- B. $\frac{3MR^2}{2}$
- C. MR^2
- D. $\frac{5MR^2}{4}$

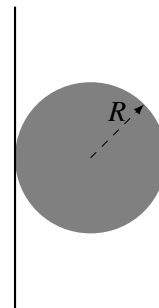

49. A pendulum is made of a rigid rod (mass m , length l) and a small bob of mass M attached at one end (as shown in the figure). The rod is pivoted on the other end. What should be the minimum speed of the bob at its lowest point so that the pendulum completes a full circle?

- A. $\sqrt{\frac{12M+6m}{3M+m} gl}$
- B. $\sqrt{4gl}$
- C. $\sqrt{5gl}$
- D. $\sqrt{\frac{15M+6m}{3M+m} gl}$

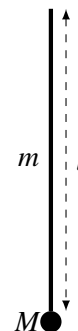

50. A proton of mass 1 a.m.u. collides with a Carbon-12 nucleus (mass = 12 a.m.u.) at rest. Assuming that the collision is perfectly elastic and that the Newton's laws of motion hold, what fraction of the proton's kinetic energy is transferred to the Carbon nucleus?

- A. $\frac{144}{169}$
 B. $\frac{48}{169}$
 C. $\frac{25}{169}$
 D. 1

51. The magnitude of the gravitational force experienced by a small spaceship of mass M inside an inter-galactic dust cloud (assumed to be spherically symmetric but not necessarily uniform) when it is at a distance of r from the center of the cloud is found to be

$$F(r) = \alpha r + \frac{\beta}{r}.$$

The density of the dust cloud is (G is Newton's gravitational constant)

- A. $\frac{3\alpha}{4\pi GM} \left(1 - \frac{\beta}{3\alpha r^2}\right)$
 B. $\frac{3\alpha}{4\pi GM} \left(1 + \frac{\beta}{3\alpha r^2}\right)$
 C. $\frac{3\alpha}{4\pi GM} \left(1 + \frac{\beta}{\alpha r^2}\right)$
 D. $\frac{3\alpha}{4\pi GM}$
52. A body cools from 67°C to 37°C . If this takes time t when the surrounding temperature is 27°C , what will be the time taken if the surrounding temperature is 7°C ?
- A. $2t$
 B. $t/3$
 C. $t/2$
 D. $t/4$

53. Three rods (lengths $2l, l, l$) made of the same material and having the same area of cross-section are joined as shown in figure. The end points A, B and C are maintained at constant temperatures $100^\circ\text{C}, 50^\circ\text{C}$ and 0°C , respectively. Assuming that there is no loss of heat from the surface of the rods, find the temperature that the junction P ultimately reaches.

- A. 50°C
 B. 40°C
 C. 30°C
 D. 20°C

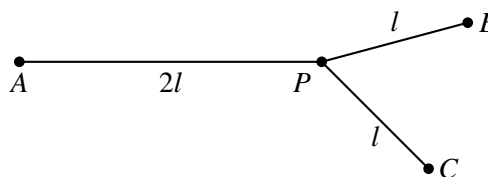

54. An AC voltage source of frequency 50 Hz and amplitude v_0 is turned on at time $t = 0$. A second voltage source of the same frequency and amplitude is turned on at a later time $t = 5$ ms. For both sources, the voltage is found to increase immediately after being turned on. The instantaneous voltage of the two sources can be represented respectively by $v_1(t)$ and $v_2(t)$, where

- A. $v_1(t) = -v_0 \sin(100\pi t)$ and $v_2(t) = +v_0 \cos(100\pi t)$

- B. $v_1(t) = +v_0 \sin(100\pi t)$ and $v_2(t) = +v_0 \cos(100\pi t)$
 C. $v_1(t) = -v_0 \sin(100\pi t)$ and $v_2(t) = -v_0 \cos(100\pi t)$
 D. $v_1(t) = +v_0 \sin(100\pi t)$ and $v_2(t) = -v_0 \cos(100\pi t)$
55. A charged particle (mass m , charge $+q$) is moving in a region of uniform magnetic field $B_0 \hat{k}$. If at time $t = 0$ the particle is at the origin and has a velocity $\vec{u} = u_x \hat{i} + u_z \hat{k}$, what is the position vector \vec{r} of the particle at a later time $\frac{9\pi m}{qB_0}$?
- A. $\vec{r} = \frac{2mu_x}{qB_0} \hat{j} + \frac{9\pi mu_z}{qB_0} \hat{k}$
 B. $\vec{r} = -\frac{2mu_x}{qB_0} \hat{j} + \frac{9\pi mu_z}{qB_0} \hat{k}$
 C. $\vec{r} = \frac{9\pi mu_z}{qB_0} \hat{k}$
 D. $\vec{r} = \frac{2m\sqrt{u_x^2 + u_z^2}}{qB_0} \hat{j}$
56. A bar magnet of mass m is suspended from the ceiling with a massless string and is set into oscillations. A gold metal plate is brought close to the oscillating pendulum. The oscillations will damp due to induction of eddy currents in the metal. Which one of the following statements is true if the gold plate is replaced by a steel plate having the same physical dimensions. (Of the two, note that gold is a better conductor of electricity.)
- A. the amplitude of oscillations will decrease faster
 B. the amplitude of oscillations will decrease slower
 C. the amplitude of oscillations will increase
 D. the amplitude of oscillations will not be affected
57. A charged particle is moving away from a uniformly charged infinite wire along a direction perpendicular to it. Initially, the particle is at a distance L from the wire moving with a velocity u . When it is at a distance $2L$, its velocity is found to be $2u$. What will be the velocity of the particle when it is at a distance $4L$ from the wire ?
- A. $\sqrt{6}u$
 B. $\sqrt{7}u$
 C. $\sqrt{8}u$
 D. $\sqrt{9}u$
58. A steel wire of length 1 meter is under a tension of 10 newtons. The speed of the transverse wave excited in this wire is v . The wire is replaced by another steel wire of the same length but half the diameter. What should be the tension in the replaced wire, so that, the speed of the wave stays the same?
- A. 40 N
 B. 20 N
 C. 5 N
 D. 2.5 N

59. Consider the circuit shown in the figure. In which resistor the amount of power dissipated is the largest?

- A. R1
- B. R2
- C. R3
- D. R4

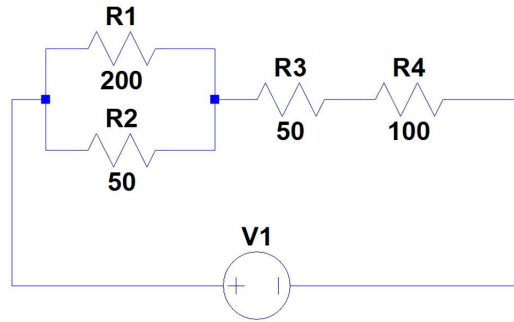

60. A biconvex lens with focal length f in air and refractive index of 1.5 is floating on the surface of a deep pond of water (refractive index 1.33). If an object is placed at a height of $2f$ vertically above the lens, then the distance between the lens and the image is

- A. f
 - B. $2f$
 - C. less than $2f$
 - D. greater than $2f$
-