

**DESIGN OF THE SAMPLE QUESTION PAPERS
MATHEMATICS-CLASS X**

Time : 3 Hours

Max. Mark : 100

The weightage or the distribution of marks over different dimensions of the question paper shall be as follows :

1. Weightage to Learning Outcomes

S. No.	Learning Outcomes	Marks
1.	Knowledge	31
2.	Understanding	45
3.	Application	12
4.	Skill	12

2. Weightage to content/subject Unit

S. No.	Learning Outcomes	Marks
1.	Algebra	26
2.	Commerical Mathematics	12
3.	Mensuration	10
4.	Trigonometry	10
5.	Geometry	22
6.	Statistics	12
7.	Coordinate Geometry	8

Total : 100

3. Weightage to form of questions

S. No.	Form of Question	Marks for each question	Number of questions	Total Marks
1.	SA I	3	10	30
2.	SA II	4	10	40
3.	LA	6	05	30

4. The expected length of answer under different forms of questions and expected time would be as follows :

S. No.	Form of Questions	No. of credit points	Approx. Time
1.	Short answer type (SA I)	Upto 4 Credit Points	3-5 minutes
2.	Short answer type (SA II)	Upto 6 Credit Points	5-7 minutes
3.	Long answer type (LA)	Upto 8 Credit Points	8-10 minutes

These ranges of steps and time requirements for the answers are, however, suggestive. In practice, actual number of steps and time needed may vary. As the total time is calculated on the basis of the number of questions required to be answered and the length of their anticipated answers, it would, therefore, be advisable for the candidates to budget their time properly by cutting out the superfluous lengths and be within the expected limits.

5. Scheme of Options

All questions are compulsory i.e. there is no overall choice in the question paper. However, internal choices have been provided in two questions of 3 marks each, two questions of 4 marks each and two questions of 6 marks each. These choices have been given from within the same topic and in questions which test higher mental abilities of students.

6. Weightage to difficulty level of questions

S. No.	Estimated Difficulty Level of Questions	% of Marks
1.	Easy	15%
2.	Average	70%
3.	Difficult	15%

A question may vary in difficulty level from individual to individual. As such, the assessment in respect of each question will be made by the paper setter on the basis of general anticipation from the group as whole taking the examination. This provision is only to make the paper balanced in its weight, rather to determine the pattern of marking at any stage.

Based on the above design, there are two separate sample papers along with their Blue Prints as well as questionwise analysis. For the examination of the Board, while the design of the question papers will remain same, blue prints based on this design may change.

Note : Though weightages to content/subject units, objectives and forms of questions etc. have been clearly assigned, yet depending on the exigencies of the paper, these can vary to some extent in Board's examination.

BLUE PRINT-I

Subject : Mathematics
Time : Three Hours

Class : X
Maximum Marks : 100

Objective →	Knowledge			Understanding			Application			Skill			Total
	LA	SA	SAI	LA	SA	SAI	LA	SA	SAI	LA	SA	SAI	
Form of → questions Content Unit		I	II		I	II		I	II		I	II	
<u>Algebra</u>													
Linear Eqns	-	-	3(1)	-	-	-	-	-	-	-	4(1)	-	7(2)
Polynomials	-	-	-	-	-	3(1)	-	-	-	-	-	-	3(1)
Rational Exp.	-	-	3(1)	-	-	-	-	-	-	-	-	-	3(1)
Quadratic Eqns	-	-	3(1)•	-	4(1)	-	-	-	-	-	-	-	7(2)
Arith. Prog.	-	-	3(1)•	-	-	3(1)	-	-	-	-	-	-	6(2)
Sub Total	-	-	12(4)	-	4(1)	6(2)	-	-	-	-	4(1)	-	26(8)
<u>Comm. Maths</u>													
Instalments	-	-	3(1)	-	-	3(1)	-	-	-	-	-	-	6(2)
Income Tax	-	-	-	6(1)	-	-	-	-	-	-	-	-	6(1)
Sub-Total	-	-	3(1)	6(1)	-	3(1)	-	-	-	-	-	-	12(3)
<u>Geometry</u>													
Similar Δ s	-	4*(1)											9(2)
Circles		4 ** (1)											9(2)
Constructions											4(1)		4(1)
Sub-Total	-	8(2)	-	-	-	6(2)	-	-	-	-	4(1)	-	22(5)
<u>Mensuration</u>													
Trigonometry	-	-	-	-	4(1)	-	6(1)•	-	-	-	-	-	10(2)
Statistics	-	4(1)	-	-	4(1)•	6(1)•	-	-	-	-	4(1)	-	12(3)
Coordinate Geometry	-	4(1)•	-	-	4(1)	-	-	-	-	-	-	-	8(2)
Sub-Total	-	8(2)	-	-	16(4)	-	12(2)	-	-	-	4(1)	-	40(9)
Total	-	16(4)	15(5)	6(1)	20(5)	19(5)*	12(2)	-	-	-	12(3)	-	
G. Total	-	31(9)	-	-	45(11)	-	-	12(2)	-	-	12(3)	-	100(25)

SAMPLE QUESTION PAPER-I

Class X

Subject : Mathematics

Time : 3 Hours

Max Marks : 100

General Instructions :

1. All questions are compulsory.
2. The question paper consists of 25 questions divided into three sections A, B and C. Section A contains 10 questions of 3 marks each, Section B is of 10 questions of 4 marks each and Section C is of 5 questions of 6 marks each.
3. There is no overall choice. However, internal choice has been provided in two questions of three marks each, two questions of four marks each and two questions of six marks each.
4. In question on construction, the drawing should be neat and exactly as per the given measurements.
5. Use of calculators is not permitted. However, you may ask for Mathematical tables.

SECTION A

Q1. Solve the following system of equations :

$$15x + 4y = 61$$

$$4x + 15y = 72$$

Q2. Reduce the following rational expression to its lowest terms :

$$\frac{x^2 + 3x + 9}{x^2 - 25} \div \frac{x^3 - 27}{x^2 + 3x - 10}$$

Q3. PQ and RS are two parallel chords of a circle and the lines RP and SQ meet at O on producing (as shown in the given figure)

Prove that $OP=OQ$

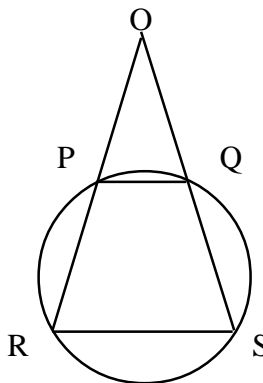

- Q4.** A suit is available for Rs. 1500 cash or for Rs. 500 cash down payment followed by 3 monthly instalments of Rs. 345 each. Find the rate of interest charged under the instalment scheme.
- Q5.** A loan has to be returned in two equal annual instalments. If the rate of interest is 16% per annum compounded annually and each instalment is of Rs. 1682, find the sum borrowed and the total interest paid.
- Q6.** If $(x - 2)$ is a factor of $x^2 + ax + b$ and $a + b = 1$, find the values of a and b .
- Q7.** Using quadratic formula, solve the following equation for x :
 $abx^2 + (b^2 - ac)x - bc = 0$

OR

The sum of the squares of two positive integers is 208. If the square of the larger number is 18 times the smaller, find the numbers.

- Q8.** Which term of the A.P. 3, 15, 27, 39.... is 132 more than its 54th term ?

OR

Derive the formula for the sum of first n terms of an A.P. whose first term is ' a ' and the common difference is ' d '

- Q9.** Find the sum of the following arithmetic progression

$$1+3+5+7+\dots\dots\dots+199$$

- Q10.** Show that a line drawn parallel to the parallel sides of a trapezium divides the non parallel sides proportionally.

SECTION B

- Q11.** Solve for x , $\frac{1}{x+1} + \frac{2}{x+2} = \frac{4}{x+4}$, ($x \neq -1, -2, -4$)

- Q12.** Find graphically, the vertices of the triangle formed by the x -axes and the lines

$$2x - y + 8 = 0$$

$$8x + 3y - 24 = 0$$

- Q13.** Construct a triangle ABC in which $BC = 13\text{cm}$, $CA = 5\text{cm}$ and $AB = 12\text{cm}$. Draw its incircle and measure its radius.

- Q14.** The total surface area of a closed right circular cylinder is 6512 cm^2 , and the circumference of its base is 88 cm . Find the volume of the cylinder (use $\pi = \frac{22}{7}$)

- Q15.** Prove the identity :
 $(1 + \cot\theta - \operatorname{Cosec}\theta)(1 + \tan\theta + \sec\theta) = 2$.

OR

Without using trigonometric tables, evaluate :

$$\frac{\cos 35^\circ}{\sin 55^\circ} + \frac{\tan 27^\circ \tan 63^\circ}{\sin 30^\circ} - 3\tan^2 60^\circ$$

- Q16.** Show that the points (7, 10), (-2, 5) and (3, -4) are the vertices of an isosceles right triangle.

OR

Using distance formula, show that the points (-1, -1), (2, 3) and (8, 11) are collinear.

- Q17.** Find the ratio in which the point (-3, p) divides the line segment joining the points (-5, -4) and (-2, 3). Hence find the value of p.

- Q18.** Compute the missing frequencies ' f_1 ' and ' f_2 ' in the following data if the mean is $166 \frac{9}{26}$ and the sum of observations is 52.

Classes	140-150	150-160	160-170	170-180	180-190	190-200	sum
Frequency	5	f_1	20	f_2	6	2	=52

- Q19.** An unbiased dice is tossed
- Write the sample space of the experiment
 - Find the probability of getting a number greater than 4
 - Find the probability of getting a prime number.

- Q20.** The pie chart (as shown in the figure) represents the amount spent on different sports by a sports club in a year. If the total money spent by the club on sports is Rs. 1,08,000/-, find the amount spent on each sport.

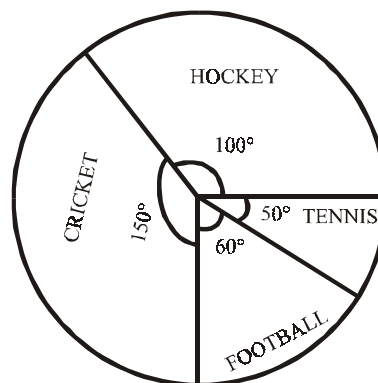

SECTION C

Q21. Prove that the angle subtended by an arc of a circle at its center is double the angle subtended by it at any point on the remaining part of the circle.

Using the above result prove that the angle in a major segment is acute.

Q22. Prove that the ratio of the areas of two similar triangles is equal to the ratio of the squares of their corresponding sides.

Using the above, prove that the area of an equilateral triangle described on the side of a square is half the area of the equilateral triangle described on its diagonal.

Q23. From the top of a tower 60m. high, the angles of depression of the top and bottom of a building whose base is in the same straight line with the base of the tower are observed to be 30° and 60° respectively. Find the height of the building.

OR

An aeroplane flying horizontally at a height of 1.5km above the ground is observed at a certain point on earth to subtend an angle of 60° . After 15 seconds, its angle of elevation at the same point is observed to be 30° . Calculate the speed of the aeroplane in km/h.

Q24. A solid toy is in the form of a hemisphere surmounted by a right circular cone. If the height of the cone is 4 cm and diameter of the base is 6 cm calculate :

- i) the volume of the toy
- ii) surface area of the toy (use $\pi = 3.14$)

OR

A bucket of height 8cm. and made up of copper sheet is in the form of frustrum of a right circular cone with radii of its lower and upper ends as 3 cm and 9 cm respectively. Calculate :

- i) the height of the cone of which the bucket is a part
- ii) the volume of water which can be filled in the bucket.
- iii) the area of copper sheet required to make the bucket (Leave the answer in terms of π)

Q25. Anil's total annual salary excluding HRA is Rs. 1,96,000. He contributes Rs., 5000 per month in his G.P.F. How much he should invest in N.S.C. to get maximum rebate? After getting maximum rebate he wants to pay income tax in equal monthly instalments. Find the amount which should be deducted per month towards tax from his salary.

Assume the following for calculating income tax :

- a) Standard deduction : (i) 40% of the total income subject to a maximum of Rs. 30,000/- in case the total annual income is up to Rs. 100,000.
(ii) Rs. 30,000/- in case the total annual income is from Rs. 100,001 to Rs. 500,000.
- b) Rate of income Tax :
- | Slab | Income Tax |
|--------------------------------------|---|
| i) Up to Rs. 50,000 | No tax |
| ii) From Rs. 50,001 to Rs. 60,000 | 10% of the amount exceeding Rs. 50,000 |
| iii) From Rs. 60,001 to Rs. 1,50,000 | Rs. 1000 + 20% of the amount exceeding Rs. 60,000 |
| iv) Above Rs. 1,50,000 | Rs. 19,000 + 30% of the amount exceeding Rs. 1,50,000 |
- c) Rebate in income tax : i) 20% of the amount of saving subject to maximum Rs. 14,000/-, if gross income is upto Rs. 1,50,000
ii) 15% of the amount of saving subject to a maximum of Rs. 10,500/-if gross income is above Rs. 1,50,000 but not exceeding Rs. 500,000

MARKING SCHEME

SECTION A

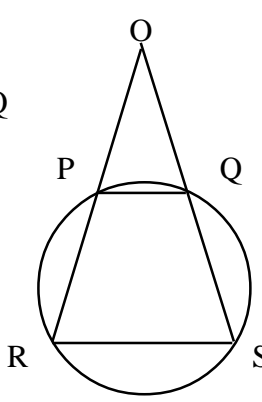
Q. NO.	VALUE POINTS	Marks
Q1.	$15x + 4y = 61$	
	$4x + 15y = 72$	
	Adding the equations we get	
	$x + y = 7$ (i)	1
	Subtracting we get	
Q1.	$x - y = -1$(ii)	1
	Solving (i) & (ii)	1
Q2.	$x = 3, y = 4$	
	Writing as $\frac{x^2 + 3x + 9}{(x+5)(x-5)} \times \frac{(x+5)(x-2)}{x^3 - 3^3}$	1
	$= \frac{x^2 + 3x + 9}{(x+5)(x-5)} \times \frac{(x+5)(x-2)}{(x-3)(x^2+3x+9)}$	1
	$= \frac{x - 2}{(x-5)(x-3)}$	1
	Q3.	$\angle POQ = \angle RSQ$ - Ext. angle of cyclic quad PRSQ
$\angle OQP = \angle RSQ$ - (PQ RS)		1
$\therefore \angle OPQ = \angle OQP$		½
$\therefore OP = OQ$		½
		
Q4.	Cash Price = Rs. 1500	
	Price under Instalment Plan = Rs. 500 + Rs. 1035 = Rs. 1535	
	Interest Charged = Rs. 35	1
	Principal for each month = Rs. 1000 + Rs. 655 + Rs. 310	
	\therefore Total Principal = Rs. 1965	1
Q4.	Rate = $\frac{35 \times 100 \times 12}{1965 \times 1} = \frac{2800}{131} = 21.31\%$ approx	1

Q. NO.	VALUE POINTS	Marks
--------	--------------	-------

Q8. Here $a = 3$, $d = 12$
 $\therefore t_{54} = 3 + (54 - 1) \cdot 12 = 639$ 1
 Let n be number of terms
 $\therefore t_n = 639 + 132 = 771$ $\frac{1}{2}$
 $\Rightarrow 3 + (n - 1) \cdot 12 = 771$ 1
 $\therefore n = 65$ $\frac{1}{2}$

OR

Writing $S_n = a + (a+d) + (a+2d) + \dots + \ell$. Where $\ell = a + (n-1)d$ 1
 $\therefore S_n = \ell + (\ell - d) + (\ell - 2d) + \dots + a$
 $\therefore 2S_n = (a + \ell) + (a + \ell) + (a + \ell) + \dots + (a + \ell) = n(a + \ell)$ 1
 $S_n = \frac{n}{2}(a + \ell) = \frac{n}{2}[2a + (n - 1)d]$ 1

Q9. Here $a=1$, $d=2$
 Let $t_n = 199$
 $\therefore 1 + (n-1) \cdot 2 = 199$ 1
 $\therefore n = 100$ $\frac{1}{2}$
 $\therefore S_{100} = \frac{100}{2} \cdot [2 \cdot 1 + (100 - 1) \cdot 2]$ 1
 $= 50 [200]$
 $= 10,000$ $\frac{1}{2}$

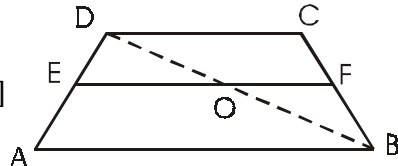
Q10. Correct figure $\frac{1}{2}$
 1
 In $\triangle ABD$, $\frac{DE}{EA} = \frac{DO}{OB}$ ----- (i) [$EO \parallel AB$]
 Similarly in $\triangle BCD$, $\frac{DO}{OB} = \frac{CF}{FB}$ ----- (ii) $\frac{1}{2}$
 (i) and (ii) $\Rightarrow \frac{DE}{EA} = \frac{CF}{FB}$ 1

SECTION B

Q11. $\frac{3x + 4}{(x+1)(x+2)} = \frac{4}{x+4}$ 1
 $\Rightarrow 4(x+1)(x+2) = (x+4)(3x+4)$ $\frac{1}{2}$
 or $4x^2 + 12x + 8 = 3x^2 + 16x + 16$ $\frac{1}{2}$
 or $x^2 - 4x - 8 = 0$ 1
 Solving to get $x = 2 + 2\sqrt{3}, 2 - 2\sqrt{3}$, 1

Q. NO.

VALUE POINTS

Marks

Q12. $2x - y + 8 = 0$

x	-3	-4	0
y	2	0	8

$8x + 3y - 24 = 0$

x	0	3	6
y	8	0	-8

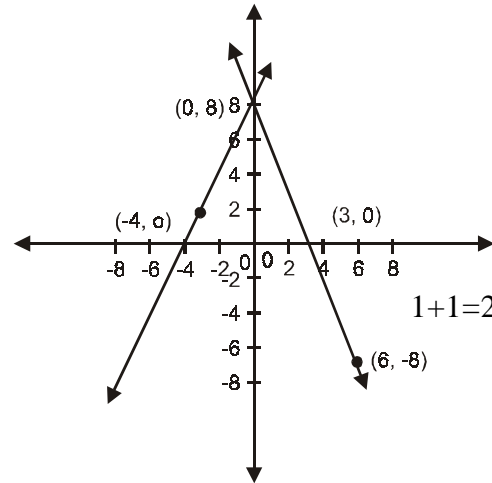

Correct graph of two lines with vertices as $(0, 8)$, $(-4, 0)$ and $(3, 0)$

Q13. Correct Construction :

Correct Measurement of radius :

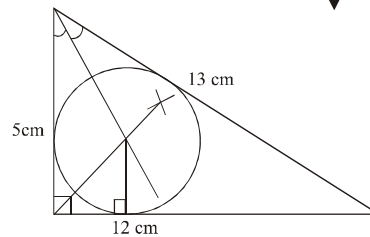

3 marks

1 mark

Q14. Let radius of base of cylinder = r cm.

$\therefore 2\pi \frac{22}{7} r = 88$

$\Rightarrow r = 14$ cm

Again $2\pi rh + 2\pi r^2 = 6512$ cm²

$\therefore h = \frac{6512}{88} - 14 = 60$ cm

Volume = $\frac{22}{7} \times 14 \times 14 \times 60$

= 36960 cm³

Q15. L.H.S.

$\left(\frac{\sin\theta + \cos\theta - 1}{\sin\theta} \right) \left(\frac{\sin\theta + \cos\theta + 1}{\cos\theta} \right)$

= $\frac{(\sin\theta + \cos\theta)^2 - 1}{\sin\theta \cdot \cos\theta}$

= $\frac{2\sin\theta \cos\theta}{\sin\theta \cdot \cos\theta} = 2$

L.H.S. = R.H.S.

1/2

1/2

1

1

1 1/2

1 1/2

1

1

1

1

Q. NO.	VALUE POINTS	Marks
--------	--------------	-------

OR

$$\frac{\cos 35^\circ}{\sin (90^\circ - 35^\circ)} + \frac{\tan 27^\circ \tan (90^\circ - 27^\circ)}{\sin 30^\circ} - 3 \tan^2 60^\circ \quad 2$$

$$= \frac{\cos 35^\circ}{\cos 35^\circ} + \frac{\tan 27^\circ \cdot \cot 27^\circ}{\sin 30^\circ} - 3 \tan^2 60^\circ \quad 1$$

$$= 1 + 2 - 9$$

$$= -6 \quad 1$$

Q16. Let A = (7, 10) ; B = (-2, 5) ; C = (3, -4) 1/2

$$\therefore AB = \sqrt{(-2-7)^2 + (5-10)^2} \quad 1/2$$

$$= \sqrt{106}$$

$$BC = \sqrt{(3+2)^2 + (-4-5)^2}$$

$$= \sqrt{106} \quad 1/2$$

$$CA = \sqrt{(7-3)^2 + (10+4)^2}$$

$$= \sqrt{16 + 196}$$

$$= \sqrt{212} \quad 1/2$$

$$\Rightarrow AB=BC \quad 1/2$$

$$\text{and } CA^2 = AB^2 + BC^2 \quad 1$$

\therefore A, B & C are vertices of an isosceles rt. triangle 1/2

OR

Let A = (-1, -1); B = (2, 3) ; C=(8, 11) 1/2

$$AB = \sqrt{(2+1)^2 + (3+1)^2}$$

$$= \sqrt{25} = 5 \quad 1/2$$

$$BC = \sqrt{(8-2)^2 + (11-3)^2}$$

$$= \sqrt{36+64} \quad 1/2$$

$$= 10$$

$$CA = \sqrt{(-1-8)^2 + (-1-11)^2}$$

$$= \sqrt{225} \quad 1/2$$

$$= 15$$

$$\therefore CA = AB + BC \quad 1$$

\therefore (-1, -1) ; (2, 3) and (8, 11) are collinear 1

Q. NO.	VALUE POINTS	Marks																											
Q17.	Let the ratio be $K : 1$ in which x, y divides the join of $(-5, -4)$ and $(-2, 3)$																												
	$\therefore x = \frac{-2K - 5}{K+1}$	1																											
	$y = \frac{3K - 4}{K+1}$	1																											
	$\therefore \frac{-2K - 5}{K+1} = -3$ (i) and $\frac{3K - 4}{K+1} = p$ (ii)	1																											
	$\Rightarrow K=2 \therefore$ Ratio is 2:1	$\frac{1}{2}$																											
	Putting value of K in (ii) we get $p = \frac{2}{3}$	$\frac{1}{2}$																											
Q18.	<table border="0" style="width: 100%;"> <tr> <td style="width: 5%;">x</td> <td style="width: 10%;">145</td> <td style="width: 10%;">155</td> <td style="width: 10%;">165</td> <td style="width: 10%;">175</td> <td style="width: 10%;">185</td> <td style="width: 10%;">195</td> <td style="width: 10%;">sum</td> <td style="width: 10%;"></td> </tr> <tr> <td>f</td> <td>5</td> <td>f_1</td> <td>20</td> <td>f_2</td> <td>6</td> <td>2</td> <td>52</td> <td></td> </tr> <tr> <td>f . x</td> <td>725</td> <td>$155f_1$</td> <td>3300</td> <td>$175f_2$</td> <td>1110</td> <td>390</td> <td>$5525 + 155f_1 + 175f_2$</td> <td></td> </tr> </table>	x	145	155	165	175	185	195	sum		f	5	f_1	20	f_2	6	2	52		f . x	725	$155f_1$	3300	$175f_2$	1110	390	$5525 + 155f_1 + 175f_2$		$\frac{1}{2}$
x	145	155	165	175	185	195	sum																						
f	5	f_1	20	f_2	6	2	52																						
f . x	725	$155f_1$	3300	$175f_2$	1110	390	$5525 + 155f_1 + 175f_2$																						
	Mean = $166 \frac{9}{26} = \frac{4325}{26} \therefore \sum fx = \frac{4325}{26} \cdot 52 = 8650$	$\frac{1}{2}$																											
	Also $f_1 + f_2 = 52 - 33 = 19 \Rightarrow f_2 = 19 - f_1$																												
	$\therefore 8650 = 5525 + 155f_1 + 175(19 - f_1)$	1																											
	$\Rightarrow f_1 = 10$	$\frac{1}{2}$																											
	$\therefore f_2 = 19 - 10 = 9$	$\frac{1}{2}$																											
Q19.	(i) Sample space = $\{1, 2, 3, 4, 5, 6\}$	1																											
	(ii) Numbers greater than 4 = 5, 6	$\frac{1}{2}$																											
	\therefore Probability = $\frac{2}{6} = \frac{1}{3}$	1																											
	(iii) Prime numbers = 2, 3, 5	$\frac{1}{2}$																											
	\therefore Probability = $\frac{3}{6} = \frac{1}{2}$	1																											
Q20.	For total expenditure on sports Rs. 108,000, Central angle = 360°	1																											
	\therefore Expenditure on Hockey = $108,000 \times \frac{100}{360} = \text{Rs. } 30,000$	1																											
	Expenditure on - cricket = $108,000 \times \frac{150}{360} = \text{Rs. } 45,000$	1																											
	Expenditure on football = $108,000 \times \frac{60}{360} = \text{Rs. } 18,000$	$\frac{1}{2}$																											
	Expenditure on Tennis = $108,000 \times \frac{50}{360} = \text{Rs. } 15,000$	$\frac{1}{2}$																											

Q. NO.

VALUE POINTS

Marks

SECTION C

Q21. No Figure no marks

Correct, Fig. given, To prove and Construction

Correct Proof

Proof : $2 \angle APB = \angle AOB$

($\angle AOB < 180^\circ$)

$\Rightarrow \angle APB < 90^\circ$

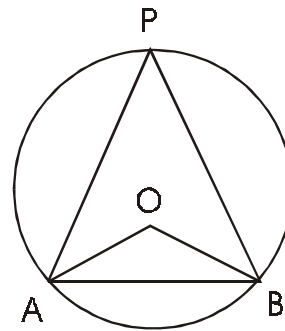

$\frac{1}{2} \times 4 = 2$

2

$\frac{1}{2}$

Fig. $\frac{1}{2}$

$\frac{1}{2}$

$\frac{1}{2}$

Q22. No figure no marks

correct fig, given, to prove, construction

2 marks ($\frac{1}{2}$ each)

correct proof

2

(ii) Proof Let side of square = a cm \therefore diagonal = $\sqrt{2}a$ cm

$\frac{1}{2}$

$\Delta APD \cong \Delta AQC$ (Equilateral)

fig. $\frac{1}{2}$

$$\therefore \frac{\text{area } \Delta APD}{\text{area } \Delta AQC} = \frac{AD^2}{AC^2}$$

$$= \frac{1}{2}$$

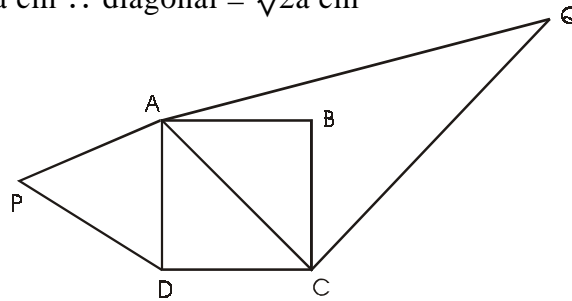

$\frac{1}{2}$

$\frac{1}{2}$

Q23. Let Tower AB = 60 m and Building be DC

In ΔADB -----

$$\frac{AB}{BD} = \tan 60^\circ$$

$$\therefore BD = \frac{60}{\sqrt{3}} = 20\sqrt{3} \text{ m}$$

$$\therefore CP = 20\sqrt{3} \text{ m}$$

Again in ΔACP -----

$$\frac{AP}{CP} = \tan 30^\circ$$

$$\Rightarrow AP = 20 \text{ m}$$

Height of Building = $CD = PB = AB - AP$

$$= 60 - 20$$

$$= 40 \text{ m}$$

1

Correct figure

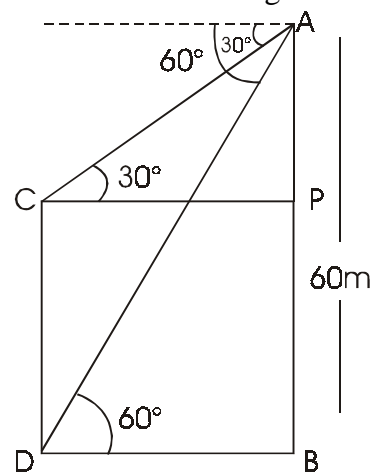

1

1

$\frac{1}{2}$

1

$\frac{1}{2}$

1

Q. NO.

VALUE POINTS

Marks

OR

Let A and B are two positions of the aeroplane. Let AB = d

Correct fig

1

$$\therefore \frac{OL}{AL} = \cot 60^\circ \Rightarrow OL = 1.5 \left(\frac{1}{\sqrt{3}} \right) = (0.5) \sqrt{3} \text{ km}$$

$$\frac{OM}{BM} = \cot 30^\circ \Rightarrow OM = (1.5) (\sqrt{3}) \text{ km}$$

$$\therefore d = OM - OL = (1.5) \sqrt{3} - (0.5) \sqrt{3} = \sqrt{3} \text{ km}$$

$$\therefore \text{speed} = \frac{\text{Distance}}{\text{time}} = \frac{\sqrt{3}}{\frac{15}{3600}} = 240 \sqrt{3} \text{ km/hr}$$

or 415.68 km/hr

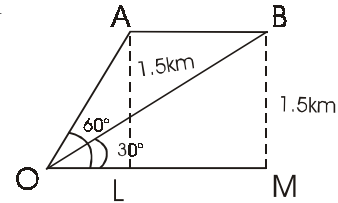

1½

1½

1

1

Q24. Volume of toy = $\left[\frac{1}{3} \pi(3)^2 \cdot 4 + \frac{2}{3} \pi(3)^3 \right] \text{ cm}^3$

$$= [12\pi + 18\pi] \text{ cm}^3$$

$$= 30 \times 3.14 = 94.20 \text{ cm}^3$$

$$\text{slant height of cone} = \sqrt{3^2 + 4^2} = 5 \text{ cm}$$

Total surface Area

$$= [\pi(3)(5) + 2\pi(3^2)] \text{ cm}^2$$

$$= (15\pi + 18\pi) \text{ cm}^2$$

$$= 33(3.14) = 103.62 \text{ cm}^2$$

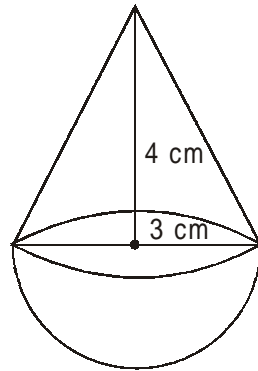

½

1

1

1

½

1

OR

Let ABCD be the bucket which is the frustrum of a cone with vertex O (as in fig.)

Let ON = x

$$\Delta ONB \sim \Delta OMC \therefore \frac{x}{x+8} = \frac{3}{9} \Rightarrow x = 4$$

$$\therefore \text{height of cone} = 8 + 4 = 12 \text{ cm}$$

$$\text{Volume of bucket} = [\pi(9)^2 \cdot 12 - \pi(3)^2 \cdot 4] \text{ cm}^3$$

$$= 312 \pi \text{ cm}^3$$

$$\text{Slant height of cone of radius 9cm} = \sqrt{9^2 + 12^2} \text{ cm}$$

$$\therefore L = 15 \text{ cm}$$

$$\text{Slant height of cone of radius 3cm} = \sqrt{3^2 + 4^2} \text{ cm}$$

$$l = 5 \text{ cm}$$

Area of the copper sheet used to form bucket

$$= [\pi(9)(15) - \pi(3)(5) + \pi(3)^2] \text{ cm}^2$$

$$129\pi \text{ cm}^2$$

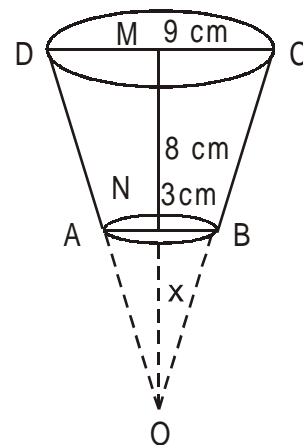

½

1

½

1

½

½

½

1

½

Q. NO.	VALUE POINTS	Marks
Q25.	Taxable Income = Rs. [1,96,000 — 30,000] = Rs. 1,66,000	½
	Income Tax = Rs. [19,000 + 30% of 16,000] = Rs. 23,800	1
	Savings in GPF = Rs. [12 x 5,000] Rs. 60,000	½
	∴ Amount to be invested in NSC for maximum rebate	1
	= Rs. [70,000 — 60,000] = Rs. 10,000	1
	∴ Maximum rebate availed = Rs. [70,000 x $\frac{15}{100}$] = Rs. 10,500	1
	Net tax = Rs. [23800 — 10500] = Rs. 13300	1
	Total tax to be paid per month = Rs. $\frac{13300}{12}$ = Rs. 1108	

BLUE PRINT-II

Subject : Mathematics
Time : Three Hours

Class : X
Maximum Marks : 100

Objective →	Knowledge			Understanding			Application			Skill			Total			Grand
	LA	SA1	SA2	LA	SA1	SA2	LA	SA1	SA2	LA	SA1	SA2	LA	SA1	SA2	
Form of →																
Question Unit																
Algebra																
Linear Eqns	-	-	4(1)	-	-	-	-	-	-	-	-	3(1)	-	4(1)	3(1)	7(2)
Polynomials	-	-	-	-	4(1)	-	-	-	-	-	-	-	-	4(1)	-	4(1)
Rational Exp.	-	4(1)	-	-	-	-	-	-	-	-	-	-	-	4(1)	-	4(1)
Quadratic Eqns	-	4(1)	-	-	4(1)	-	-	-	-	-	-	-	-	8(2)	-	8(2)
Arith. Prog.	-	-	-	-	-	3(1)	-	-	-	-	-	-	-	-	3(1)	3(1)
Sub Total	-	12(3)	-	-	8(2)	3(1)	-	-	-	-	3(1)	-	-	20(5)	6(2)	26(7)
Comm. Maths																
Instalments	-	-	3(1)	-	-	3(1)	-	-	-	-	-	-	-	-	6(2)	6(2)
Income Tax	-	-	-	6(1)	-	-	-	-	-	-	-	-	6(1)	-	-	6(1)
Sub-Total	-	-	3(1)	6(1)	-	3(1)	-	-	-	-	-	-	6(1)	-	6(2)	12(3)
Geometry																
Similar Δ s	4*(1) **	-	-	-	-	2* 3(1) **	-	-	-	-	-	-	-	6(1)* ***•	3(1)	9(2)
Circles	4(1)	-	-	-	4(1)	2	-	-	-	-	-	-	6(1)	4(1)	-	10(2)
Constructins	-	-	-	-	-	-	-	-	-	-	-	3(1)	-	-	3(1)	3(1)
Sub-Total	8(2)	-	-	-	4(1)	7(1)	-	-	-	-	3(1)	-	12(2)	4(1)	6(2)	22(5)
Mensuration	-	-	4(1)	-	-	-	-	-	-	-	-	-	-	4(1)	6(2)	10(3)
Trigonometry	-	-	-	-	4(1)•	-	6(1)•	-	-	6(2)•	-	-	-	4(1)	-	10(2)
Statistics	-	-	-	-	-	6(2)•	-	-	-	-	-	-	6(1)	-	6(2)	12(3)
Coordinate Geometry	-	4(1)	-	-	4(1)•	-	-	-	-	-	-	-	-	8(2)	-	8(2)
Sub-Total	-	8(2)	-	-	8(2)	6(2)	6(1)	6(1)	-	6(2)	-	-	12(2)	16(4)	12(4)	40(10)
Total	-	8(2)	-	-	8(2)	6(2)	6(1)	6(1)	-	6(2)	-	6(2)	40(10)	30(10)	30(10)	100(25)
G. Total		31(8)			45(11)				12(3)			12(3)		100(25)		

Sample Question Paper-II

Class X

Subject : Mathematics

Time : 3 Hours

Max Marks : 100

General Instructions :

1. All questions are compulsory.
2. The question paper consists of 25 questions divided into three sections A, B and C. Section A contains 10 questions of 3 marks each, Section B is of 10 questions of 4 marks each and Section C is of 5 questions of 6 marks each.
3. There is no overall choice. However, internal choice has been provided in two questions of three marks each, two questions of four marks each and two questions of six marks each.
4. In question on construction, the drawing should be neat and exactly as per the given measurements.
5. Use of calculators is not permitted. However, you may ask for Mathematical tables.

SECTION A

- Q1.** Solve the following system of equations graphically
- $$5x - y = 7$$
- $$x - y = -1$$
- Q2.** Find the Arithmetic Progression whose third term is 16 and the seventh term exceeds its fifth term by 12.
- Q3.** ABD is a triangle in which $\angle DAB = 90^\circ$. AC is drawn perpendicular from A to DB. Prove that :
- $$AD^2 = BD \times CD$$
- Q4.** A loan of Rs. 48,800/- is to be paid back in three equal annual instalments. If the rate of interest is 25% per annum compounded annually, find the instalment.
- Q5.** A watch is available for Rs. 970 cash or Rs. 210 as cash down followed by three equal monthly instalments. If the rate of interest is 16% per annum, find the monthly instalment.
- Q6.** Construct the pair of tangents drawn from a point, 5cm away from the centre of a circle of radius 2cm. Measure the lengths of the tangents.
- Q7.** A solid metallic cylinder of radius 14cm and height 21 cm is melted and recast into 72 equal small spheres. Find the radius of one such sphere.

- Q8.** The rain water from a roof 22m x 20m drains into a conical vessel having diameter of base as 2m and height 3.5m. If the vessel is just full, find the rainfall (in cm.)

OR

The largest sphere is carved out of a cube of side 7cm ; find the volume of the sphere.

- Q9.** The following table shows the marks secured by 100 students in an examination

Marks	0-10	10-20	20-30	30-40	40-50
Number	15	20	35	20	10

Find the mean marks obtained by a student.

- Q10.** A dice is thrown once. Find the probability of getting.

- (i) a number greater than 3
(ii) a number less than 5

OR

A bag contains 5 red balls, 8 white balls, 4 green balls and 7 black balls. A ball is drawn at random from the bag. Find the probability that it is.

- (i) black
(ii) not green

SECTION B

- Q11.** Solve for x and y

$$(a-b)x + (a+b)y = a^2 - 2ab - b^2$$

$$(a+b)(x+y) = a^2 + b^2$$

- Q12.** If $(x+3)(x-2)$ is the G.C.D. of

$$f(x) = (x+3)(2x^2 - 3x + a)$$

$$\text{and } g(x) = (x-2)(3x^2 + 10x - b)$$

find the value of a and b

- Q13.** If $A = \frac{2x+1}{2x-1}$, $B = \frac{2x-1}{2x+1}$, find

$$\frac{A+B}{A-B} + \frac{A-B}{A+B}$$

- Q14.** Solve for x :

$$\frac{x-1}{x-2} + \frac{x-3}{x-4} = \frac{10}{3} \quad (x \neq 2, x \neq 4)$$

- Q15.** A passenger train takes 2 hours less for a journey of 300 km if its speed is increased by 5 km/h from its usual speed. Find the usual speed of the train.

- Q16.** AB is a diameter of a circle with centre O and chord CD is equal to radius of the circle. AC and BD are produced to meet at P. Prove that $\angle CPD = 60^\circ$.

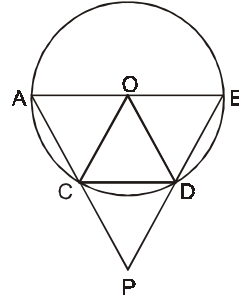

- Q17.** A circus tent is in the shape of a cylinder surmounted by a cone. The diameter of the cylindrical part is 24m and its height is 11 m. If the vertex of the tent is 16m above the ground, find the area of canvas required to make the tent.
- Q18.** Prove that :

$$\frac{\tan\theta}{1-\cot\theta} + \frac{\cot\theta}{1-\tan\theta} = 1 + \sec\theta \operatorname{cosec}\theta$$

OR

Evaluate :

$$\frac{\sin 39^\circ}{\cos 51^\circ} + 2 \tan 11^\circ \tan 31^\circ \tan 45^\circ \tan 59^\circ \tan 79^\circ - 3 (\sin^2 21^\circ + \sin^2 69^\circ)$$

- Q19.** Find a point on the x-axis which is equidistant from the points (7, 6) and (−3, 4)
- Q20.** Three consecutive vertices of a parallelogram ABCD are A(1, 2), B(1, 0) and C (4, 0). Find the fourth vertex D.

OR

If A (4, -8), B (-9, 7) and C (18, 13) are the vertices of a triangle ABC, find the length of the median through A and coordinates of centroid of the triangle.

SECTION C

- Q21.** The number of hours spent by a school boy on various activities on a working day are given below :

Activity	Number of Hours
Sleep	7
School	8
Homework	4
Play	3
Others	2

Present the above information by a pie-chart.

- Q22.** A vertical tower is surmounted by a flagstaff of height h metres. At a point on the ground, the angles of elevation of the bottom and top of the flagstaff are α and β respectively. Prove that the height of tower is :

$$\frac{h \tan \alpha}{\tan \beta - \tan \alpha}$$

OR

If the angle of elevation of a cloud from a point h meters above a lake is α and the angle of depression of its reflection in the lake is β , prove that the distance of the cloud from the point of observation is

$$\frac{2h \sec \alpha}{\tan \beta - \tan \alpha}$$

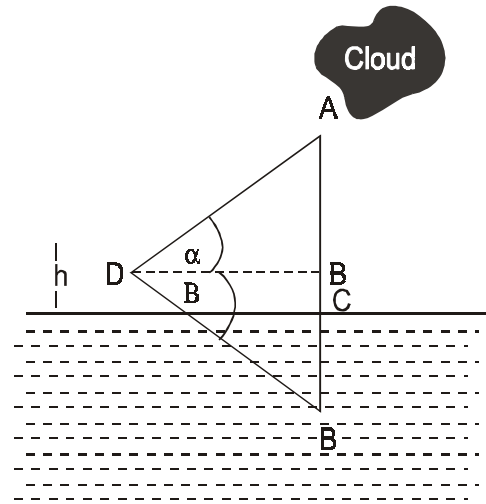

- Q23.** If a line is drawn parallel to one side of a triangle, prove that the other two sides are divided in the same ratio. Using the above result, prove the following :

The diagonals of a trapezium divide each other in the same ratio.

- Q24.** Prove that the sum of either pair of the opposite angles of a cyclic quadrilateral is 180° . Using the above result, determine as under :

ABCD is a cyclic trapezium with $AD \parallel BC$. If $\angle B = 70^\circ$, determine the other three angles of the trapezium.

OR

If two circles touch each other internally or externally, prove that the point of contact lies on the line joining their centers.

Using the above result prove the following :

Two circles with centers O and O' and radii r_1 and r_2 touch each other externally at P. AB is a line through P intersecting the two circles at A & B respectively. Prove that $OA \parallel OB'$.

Q25. Ramlal has a total annual income of Rs. 1,45,000/-. He contributes Rs. 2000 per month in his GPF and pays an annual LIC premium of Rs. 15,000. If he pays Rs. 250 per month for first 11 months as advance income tax, find the income tax liability for the last month. Use the following for calculating income tax :

- | | | |
|----|---------------------------------|---|
| a) | Standard Deduction | (i) 40% of the total income subject to a maximum of Rs. 30,000/- in case the total annual income is upto Rs. 100,000/-
(ii) Rs. 30,000/- in case the total annual income is from Rs. 100,001 to Rs.500,000/- |
| b) | Rates of Income tax | |
| | i) Upto Rs. 50,000 | No tax |
| | ii) Rs. 50,001 to Rs. 60,000 | 10% of the amount exceeding Rs. 50,000 |
| | iii)Rs. 60,0001 to Rs. 1,50,000 | Rs. 1000 + 20% of the amount exceeding Rs. 60,000. |
| c) | Rebate on Savings | 20% of the total savings if the gross income is upto, 150,000 subject to a maximum of Rs. 14,000. |

MATHEMATICS
Marking Scheme II

Q. No.	Value Points	Marks
	SECTION A	

Q1. Forming the table of values :

$$5x - y = 7 \Rightarrow \begin{array}{|c|c|c|c|} \hline x & 1 & 0 & 2 \\ \hline y & -2 & -7 & 3 \\ \hline \end{array}$$

$$x - y + 1 = 0 \Rightarrow \begin{array}{|c|c|c|c|} \hline x & -1 & 0 & 2 \\ \hline y & 0 & 1 & 3 \\ \hline \end{array}$$

Graph of lines

Getting the solution $x = 2, y = 3$

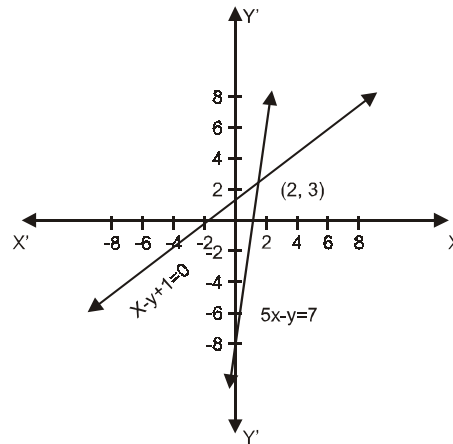

1/2

1/2

1 1/2

1/2

Q2. Let a be the first term and d , the common difference

1

\therefore Third term $= t_3 = a + 2d = 16$ (i)

Also, $t_7 - t_5 = 12$ or $(a+6d) - (a+4d) = 12 \Rightarrow d = 6$ (ii)

1/2+1/2

From (i) and (ii), getting $a = 4$

1/2

\therefore The arithmetic progression is 4, 10, 16, 22, 28.....

1/2

Q3. Correct Figure

1/2

Showing $\Delta DCA \sim \Delta DAB$

$$\therefore \frac{AD}{CD} = \frac{BD}{AD}$$

1

$$\Rightarrow AD^2 = BD \cdot CD$$

1/2

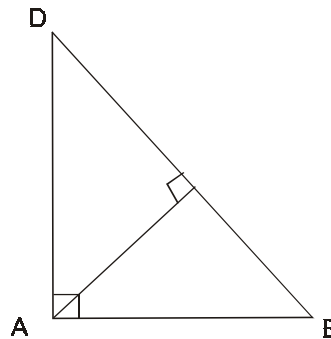

Q4. Let the instalment be Rs x

Present values of 1st, 2nd and 3rd instalments are

are $\frac{4}{5}x, \left(\frac{4}{5}\right)^2x, \left(\frac{4}{5}\right)^3x$

1 1/2

$$\therefore \frac{4}{5}x \left[1 + \frac{4}{5} + \frac{16}{25} \right] = 48800$$

1

OR $x = 25000$

\therefore each instalment = Rs. 25000

1/2

Q. No.	Value Points	Marks
--------	--------------	-------

Q5. Cash price of watch = Rs. 970
 Cash down payment = Rs. 210
 \therefore Payment to be made in instalments = Rs. (970-210) = Rs 760 1/2
 Let Rs. x be each instalment

$$\therefore \left[x + \frac{x \times 16 \times 2}{1200} \right] + \left[x + \frac{x \times 16 \times 1}{1200} \right] x = \text{Rs. } 760 \quad 1\frac{1}{2}$$

$$\text{or, } 3x + \frac{16x}{1200} \times 3 = 760$$

$$\text{or, } \frac{76}{25} x = 760 \Rightarrow x = 250 \quad 1$$

Q6.. Correct construction 3

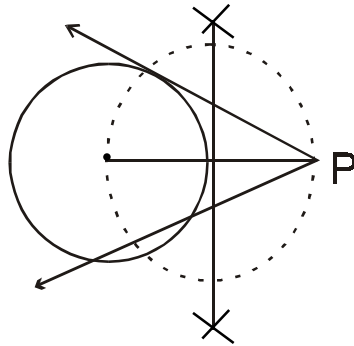

Q7. Volume of metallic cylinder = $[\pi (14)^2 \cdot 21] \text{ cm}^3$ 1

This has been melted to form 72 spheres

Let r be the radius of the sphere

$$\therefore \frac{24}{72} \times \frac{4}{3} \pi r^3 = \pi 196.21 \quad 1$$

$$r^3 = \frac{(196)(21)}{\frac{24 \times 4}{3}}$$

$$= \left(\frac{7}{2} \right)^3 \quad 1/2$$

$$\Rightarrow r = 3.5 \text{ cm} \quad 1/2$$

Q8. Let h cm be the rainfall on the roof

$$\therefore \text{volume of water collected on roof} = \frac{(22 \times 20 \times h)}{100} \text{ m}^3 = \frac{22}{5} \cdot h \text{ m}^3 \quad 1$$

$$\text{Volume of water in conical vessel} = \frac{1}{3} \pi (1)^2 \times \frac{7}{2} \text{ m}^3$$

Q. No. **Value Points** **Marks**

$$= \frac{1}{3} \times \frac{22}{7} \times \frac{7}{2} \text{ m}^3 = \frac{11}{3} \text{ m}^3 \quad 1$$

$$\Rightarrow \frac{22}{5} h = \frac{11}{3}$$

$$\Rightarrow h = \frac{11}{3} \times \frac{5}{22} = \frac{5}{6} \therefore \text{rainfall} = \frac{5}{6} \text{ cm} \quad 1$$

OR

The diameter of sphere = side of cube 1

$$\therefore \text{Radius of sphere} = \frac{7}{2} \text{ cm} \quad \frac{1}{2}$$

$$\text{Volume} = \frac{4}{3} \pi r^3 \quad \frac{1}{2}$$

$$= \frac{4}{3} \times \frac{22}{7} \times \frac{7}{2} \times \frac{7}{2} \times \frac{7}{2} = 179 \frac{2}{3} \text{ cm}^3 \quad 1$$

Q9.	C.I	xi	fi	fixi	
	0 -10	5	15	075	
	10-20	15	20	300	
	20-30	25	35	875	
	30-40	35	20	700	
	40-50	45	10	450	
		$\Sigma fi \rightarrow$	<u>100</u>	<u>2400</u>	← $\Sigma fixi$
				$\Sigma fixi$	1
				Σfi	$\frac{1}{2}$
					1
					$\bar{x} = \frac{\Sigma fixi}{\Sigma fi}$
					$= \frac{2400}{100} = 24$
					$\frac{1}{2}$

Q10. Total possible cases = 6 1/2

Numbers greater than 3 on the die = 3 (4,5,6) 1/2

\therefore (i) Probability of getting a number > 3 = 3/6 = 1/2 1

(ii) Numbers less than 5 = 4 [1,2,3,4] 1/2

\therefore Required probability = $\frac{4}{6}$ or $\frac{2}{3}$ 1/2

Q. No.	Value Points	Marks
OR		
Total no. of balls in the bag = 24		½
(i) Numbers of black balls = 7		
∴ Required probability = $\frac{7}{24}$		1
(ii) Number of balls which are not green = Total - green = 24 - 4 = 20		1
∴ Required probability = $\frac{20}{24} = \frac{5}{6}$		½

SECTION – B

Q11. (a-b)x + (a+b)y = a ² -2ab-b ² (i)		
(a+b)x +(a+b)y = a ² +b ² (ii)		1
(i) — (ii) ⇒ — 2bx = — 2b(a+b)		
⇒ x = (a+b)		1½
substituting in (i) or (ii) to get y= — $\frac{2ab}{a+b}$		1 ½
Q12. (x+3)(x-2) divides f(x)		
∴ 2x ² —3x+a has a factor (x—2)		1
∴ 2(2) ² —3(2) + a = 0		
8 — 6 + a = 0 ⇒ a = —2		1 ½
Similarly, (x + 3) divides 3x ² +10x-b		½
∴ 3(—3) ² —30 — b = 0		
⇒ b = —3		1
Q13. A+B = $\frac{(2x+1)^2+(2x-1)^2}{4x^2-1} = \frac{2(4x^2+1)}{4x^2-1}$		1
A — B = $\frac{(2x+1)^2-(2x-1)^2}{4x^2-1} = \frac{8x}{4x^2-1}$		½
∴ $\frac{A+B}{A-B} = 2 \times \frac{4x^2+1}{4x^2-1} \times \frac{4x^2-1}{8x} = \frac{4x^2+1}{4x}$		1
Similarly, $\frac{A-B}{A+B} = \frac{4x}{4x^2+1}$		½
∴ $\frac{A+B}{A-B} + \frac{A-B}{A+B} = \frac{4x^2+1}{4x} + \frac{4x}{4x^2+1} = \frac{(4x^2+1)^2+16x^2}{4x(4x^2+1)} = \frac{16x^4+24x^2+1}{16x^3+4x}$		1

Q. No.	Value Points	Marks
--------	--------------	-------

Q17. Area of canvas required to build the tent

= curved surface area of cylindrical part + curved surface of conical part

$$OA^2 = 5^2 + 12^2 = 169 \Rightarrow OA = 13 \text{ m}$$

$$\therefore \text{Required area} = 2 \pi r h + \pi r l = \pi r (2h + l)$$

$$= \frac{22}{7} \times 12(22 + 13) \text{ m}^2 = 1320 \text{ m}^2$$

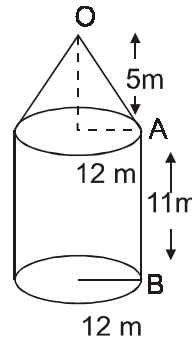

1
1
1/2
1 1/2

Q18. $\frac{\tan \theta}{1 - \cot \theta} + \frac{\cot \theta}{1 - \tan \theta} = 1 + \sec \theta \operatorname{cosec} \theta$

L.H.S $\frac{\tan \theta}{1 - \frac{1}{\tan \theta}} + \frac{1}{\tan \theta (1 - \tan \theta)} = \frac{1}{\tan \theta (1 - \tan \theta)} - \frac{\tan^2 \theta}{1 - \tan \theta}$ 1/2+1

$$= \frac{1 - \tan^3 \theta}{\tan \theta (1 - \tan \theta)} = \frac{(1 - \tan \theta)(1 + \tan \theta + \tan^2 \theta)}{\tan \theta (1 - \tan \theta)}$$
 1/2+1

$$\cot \theta + 1 + \tan \theta = 1 + \frac{\cos \theta}{\sin \theta} + \frac{\sin \theta}{\cos \theta} = 1 + \sec \theta \operatorname{cosec} \theta = \text{R.H.S.}$$
 1/2+1/2

OR

$$\cos 51^\circ = \cos(90 - 39)^\circ = \sin 39^\circ$$

$$\tan 79^\circ = \tan(90 - 11)^\circ = \frac{1}{\tan 11^\circ}$$

$$\tan 59^\circ = \tan(90 - 31)^\circ = \frac{1}{\tan 31^\circ}$$

$$\tan 45^\circ = 1$$

$$\sin 69^\circ = \sin(90 - 21)^\circ = \cos 21^\circ$$
 2 1/2

\therefore Given expression becomes

$$\frac{\sin 39^\circ}{\sin 39^\circ} + 2 \cdot \tan 11^\circ \tan 31^\circ \cdot \frac{1}{\tan 31^\circ} \cdot \frac{1}{\tan 11^\circ} - 3(\sin^2 21^\circ + \cos^2 21^\circ)$$
 1

$$= 1 + 2 - 3(1) = 0$$
 1/2

Q. No.	Value Points	Marks
Q19. Any point P on x axis is given by (x,0)		1/2
(Distance) between (x, 0) and (7, 6) is given by $\sqrt{(x - 7)^2 + 6^2}$(i)		1
(Distance) between (x, 0) and (-3, 4) is given by $\sqrt{(x + 3)^2 + 4^2}$(ii)		1
(i) = (ii) $\Rightarrow x^2 - 14x + 49 + 36 = x^2 + 6x + 9 + 16$		1
OR, $20x = 60$		
$x = 3$		
\therefore The point is (3,0)		1/2

Q20. Let the point D be (x, y)
 \therefore mid point of BD = $\left(\frac{(x+1)}{2}, \frac{y}{2}\right)$
Mid point of AC = (5/2, 1)
This is the same point
 $\therefore \frac{x+1}{2} = \frac{5}{2} \Rightarrow x=4$
and $\frac{y}{2} = 1 \Rightarrow y = 2$
 \therefore The co-ordinates of D are (4, 2)

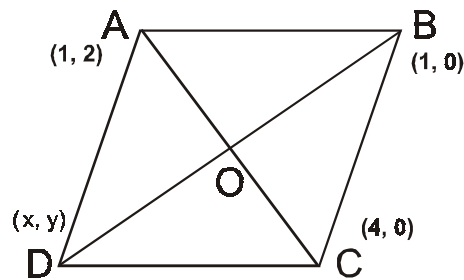

1 1/2
1

OR

Co-ordinates of D are $\left(\frac{9}{2}, 10\right)$
 \therefore The length of AD

$$\begin{aligned}
&= \sqrt{\left(4 - \frac{9}{2}\right)^2 + (-8 - 10)^2} \\
&= \sqrt{\frac{1}{4} + 324} = \sqrt{\frac{1297}{4}} \\
&= \frac{1}{2} \sqrt{1297} \\
&\text{Co-ordinates of centroid} \\
&= \left(\frac{4 - 9 + 18}{3}, \frac{-8 + 7 + 13}{3}\right) \\
&= \left(\frac{13}{3}, 4\right)
\end{aligned}$$

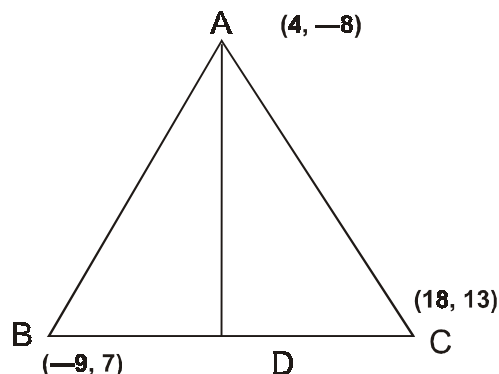

1
1/2
1
1/2

Q. No.

Value Points

Marks

SECTION C

Q21. Making the table:

Correct Central angles

2

Activity	Duration in hours	Central angle
Sleep	7	105°
School	8	120°
Home work	4	60°
Play	3	45°
Others	2	30°

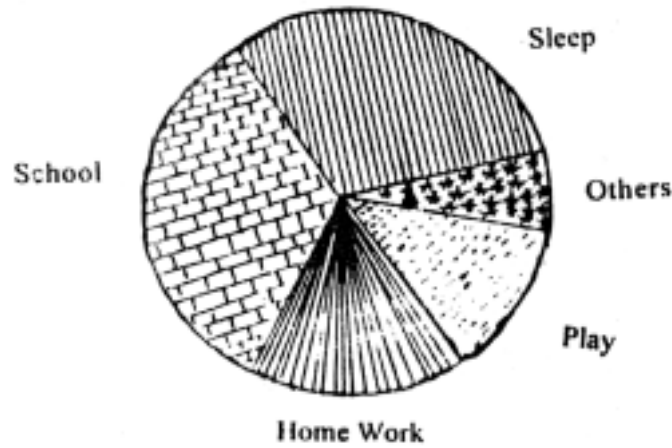

Drawing correct Pie chart with markings

4

Q22. figure

1

Writing the trigonometric equation

$$\frac{b}{x} = \tan \alpha \Rightarrow x = b \cot \alpha$$

$$\text{Again } \frac{b+h}{x} = \tan \beta \Rightarrow \frac{b+h}{b \cot \alpha} = \tan \beta$$

$$\Rightarrow (b+h) = \frac{b \tan \beta}{\tan \alpha}$$

$$\Rightarrow b \tan \alpha + h \tan \alpha = b \tan \beta$$

$$\Rightarrow h \tan \alpha = b(\tan \beta - \tan \alpha)$$

$$\Rightarrow b = \frac{h \tan \alpha}{\tan \beta - \tan \alpha}$$

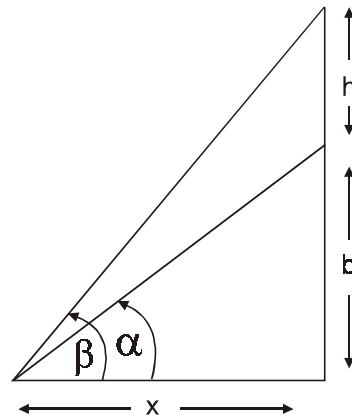

1 1/2

1

1

1

1/2

Q. No.

Value Points

Marks

OR

We have to find AD,

Let $AC = A'C = x$

$\therefore AB = x - h$, $A'B = x + h$

1

Let $BD = y$

$$\therefore \frac{AB}{BD} = \frac{x-h}{y} = \tan \alpha \Rightarrow x = h + y \tan \alpha$$

1 1/2

$$\frac{A'B}{BD} = \tan \beta$$

$$\frac{x+h}{y} = \tan \beta \Rightarrow x = y \tan \beta - h$$

1

$$\therefore h + y \tan \alpha = y \tan \beta - h \Rightarrow \frac{2h}{\tan \beta - \tan \alpha} = y$$

1

$$\frac{BD}{AD} = \cos \alpha \Rightarrow AD = y \sec \alpha$$

1

$$AD = \frac{2h \sec}{\tan \beta - \tan \alpha}$$

1/2

Q23. Given, to prove, construction and correct figure

1/2 x 4 = 2

Correct proof

Draw $OE \parallel AB$

$$\text{In } \triangle DAB, OE \parallel AB \Rightarrow \frac{AE}{ED} = \frac{BO}{OD}$$

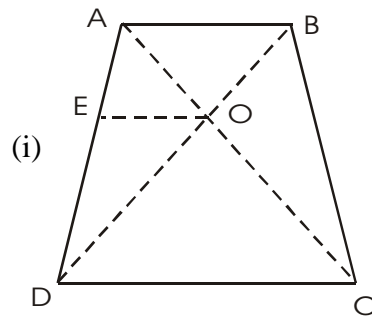

2

1/2

1/2

Similarly, In $\triangle ADC$, $EO \parallel AB \parallel DC$

$$\therefore \frac{AE}{ED} = \frac{AO}{OC} \text{ (ii)}$$

$$\text{From (i) and (ii), we get } \frac{BO}{DO} = \frac{AO}{OC}$$

1/2

Q24. Given, to prove, construction and correct figure

1/2x4=2

Correct proof

ABCD is cyclic, therefore $\angle D = 180^\circ - 70^\circ = 110^\circ$

2

1/2

Also $\angle C + \angle D = 180^\circ \Rightarrow \angle C = 180^\circ - 110^\circ = 70^\circ$

1

$\therefore \angle A = 180 - 70 = 110^\circ$

1/2

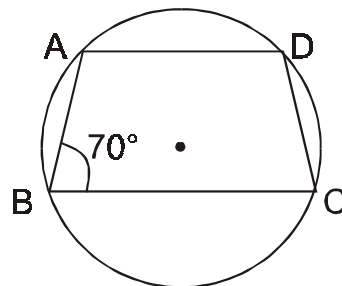

Q. No.

Value Points

Marks

OR

Given ,to prove construction & correct figure

$1/2 \times 4 = 2$

Correct proof

2

Figure $1/2$

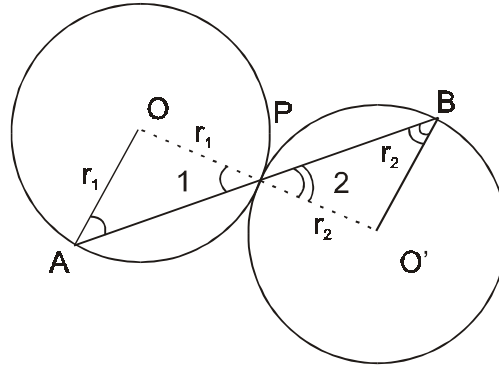

OPO' is a straight line

Since $OA = OP = r_1 \therefore \angle A = \angle 1$, Similarly $\angle B = \angle 2$

$1/2$

But $\angle 1 = \angle 2$ (vert. Opp. \angle s) $\therefore \angle A = \angle B$

$1/2$

But these are alternate angles $\therefore OA \parallel O'B$

$1/2$

Q25. Taxable income = Rs. 145000 - 30,000 = Rs. 1,15,000

$1/2$

Income tax = Rs. $\left[1000 + \frac{55000 \times 20}{100}\right]$ = Rs. 12,000

1

Annual savings = Rs $[2000 \times 12 + 15000]$ = Rs. 39,000

1

Rebate = 20% of Rs. 39000 = Rs. 7800

1

\therefore Tax = Rs. $(12000 - 7800)$ = Rs. 4200

1

Income tax paid for first 11 months = Rs. (250×11) = Rs. 2750

1

\therefore Income tax to be paid in the last month = Rs. $(4200 - 2750)$ = Rs. 1450

$1/2$