

**Section-I: General Aptitude**

- $2^{(x-1)} - 2^{(x-4)} = 7(2^{11})$, what is x ?
(A) 9 (B) 11 (C) 13 (D) 15
- Length of a rectangle increases by 20%, while its breadth reduces by 10%. Find the percentage change in its perimeter.
(A) 10% increase (B) 8% increase (C) 5% increase (D) Can't say
- In a group, average weight of the females was 60kgs. The average weight of the entire group was twice as close to the average weight of the men as it was to the average weight of the women. What percentage of the group were women?
(A) 40 (B) 33.33 (C) 50 (D) 66.67
- Govind decided to walk down the escalator of a shopping mall. He found that if he walks down 25 steps, he requires 15 seconds to reach the bottom. However, if he steps down 13 steps, he requires 24 seconds to reach the bottom. Find out the height of the stairway in steps.
(A) 30 (B) 40 (C) 45 (D) 50
- Taps A and B, operating simultaneously, can fill a certain tank in 72 min; Taps A and C, operating simultaneously, can fill the tank in 90 min; and Taps B and C, operating simultaneously, can fill the tank in 2 hours. How many hours does it take Taps A, B, and C, operating simultaneously, to fill the tank ?
(A) $\frac{1}{3}$ (B) 1 (C) $\frac{2}{3}$ (D) $\frac{5}{6}$
- A customer at Paradise hotel calculates his tip by adding a constant amount to another sum that is directly proportional to the total bill for the meal. If the total bill for his meal had been 100/- greater, the customer would've calculated a tip of 60/-. If the total bill for his meal had been 150/- less, the customer would've calculated a tip of 40/-. If his total bill for the meal was 600/- what will be the amount of his tip?
(A) 48 (B) 56 (C) 52 (D) 50
- There are five hotels in a line. If 4 men go into a hotel at 11 am, then what will be the probability that each go into a different hotel?
(A) $\frac{124}{125}$ (B) $\frac{24}{125}$ (C) $\frac{42}{125}$ (D) $\frac{48}{625}$
- In a class of 40 students, 12 enrolled for both English & German. 22 enrolled for German. If students of class enrolled at least one of the subjects, then how many students enrolled for only English & not German?
(A) 30 (B) 12 (C) 18 (D) 40



9. Mr. Vikas buys some apples at 8 per rupee from one trader and a similar quantity at 5 per rupee from another trader. He mixes both the varieties and sell the whole at 9 per rupee. What is the profit or loss percentage that he makes?
(A) 31.62 % Profit (B) 31.62 % Loss (C) 46.25 % Profit (D) 46.25 % Loss

10.

Type of program ↓	AGE Group →	15-20	21-30	31+
Daily Serials		6	4	17
Comedy		7	5	5
Singing/dancing		6	12	14
Devotional		1	4	11
News		2	3	15
Sports		9	3	4
Quiz		2	2	2
Total		33	33	68

What percentage of respondents aged 21-30 indicated a favourite program other than singing/dancing?

- (A) 36 % (B) 46 % (C) 64 % (D) 60 %
11. **Analogy**
AESTHETICS : BEAUTY ::
(A) ethics: etiquette (B) epistemology : knowledge
(C) theology: morals (D) rhetoric : reasoning
12. Choose the appropriate antonym for the word **ABOMINATE**
(A) loathe (B) despise (C) adore (D) abhor
13. Choose the sentence that is grammatically correct:
(A) The serving bowl or the plates go on that shelf
(B) The serving bowls or the plate go on that shelf
(C) The serving bowl or the plate go on that shelf
(D) The serving bowls or the plates goes on that shelf
14. The management of the company had cordially invited its staff for the 25th Anniversary function.
Choose the best conclusion:
(A) The company is going to wind-up the next year
(B) It is mandatory for all the staff to attend the function
(C) The management of the company is spend-thrift
(D) The company is well-established



15. Find out the error part in the given sentence
Ram is junior / than shyam / and Ram is / older than shyam
(A) (B) (C) (D)
16. Find the proper meaning of the words given in bold letters.
After working for years in the same company, Ramu decided to **Jack it all**.
(A) Continue (B) Change (C) Stop (D) Cheat.
17. Urban services have not expanded fast enough to cope up with urban expansion. Low investment allocations have tended to be underspent. Both public and private infrastructure quality has declined. The impact of the environment in which children live and the supporting services available to them when they fall ill, seem clear. The decline in average food availability and the rise in absolute poverty, point in the same unsatisfactory directions.
Choose the weakest statement related to the above passage
(A) Though adequate provisions of funds were made but they were received under spent
(B) Low cost urban housing is on the priority
(C) There is nothing to boast about urban services
(D) Birth rate is higher in urban areas than in rural areas
18. **Sentence completion**
Data concerning the effects on a small population of high concentrations of a potentially hazardous chemical are frequently used to ----- the effects on a large population of lower amounts of the same chemical.
(A) verify (B) redress (C) predict (D) realize
19. **Select the best alternative for the underlined part:**
Currently 93,250,000 billion barrels a year, world consumption of oil is rising at a rate of 3 percent annually.
(A) world consumption of oil is rising at a rate of
(B) the world is consuming oil at an increasing rate of
(C) the world's oil is being consumed at the increasing rate of
(D) the rise in the rate of the world's oil consumption is
20. False currency is being supplied to India through buses that run between India and Pakistan. Find out the course of action to be taken.
(A) The govt. should ban the buses
(B) The govt. should change the currency
(C) The govt. should strengthen the vigilance
(D) Indian govt. should warn the Pakistan govt.

**Section-II: Technical**

1. Let

$N(x, y)$: x and y are neighbors

$H(x, y)$: x should help y.

$P(x, y)$: x will help y.

Write the negation of the following statements in symbolic form.

“Everyone should help his neighbours, or his neighbours will not help him”.

(A) $(\forall x)(\forall y)(N(x, y) \rightarrow (H(x, y) \vee \neg P(y, x)))$

(B) $(\exists x)(\exists y)(N(x, y) \rightarrow (H(x, y) \vee \neg P(y, x)))$

(C) $(\exists x)(\exists y)(N(x, y) \wedge (\neg H(x, y) \wedge \neg P(y, x)))$

(D) $(\exists x)(\exists y)(N(x, y) \wedge \neg H(x, y) \wedge P(y, x))$

2. Which of the following statements are True/False, map them appropriately, with respect to syntax directed definitions?

I. The terminals in a SDD can have both synthesized as well as inherited attributes.

II. Value of attributes of terminals is generally supplied by lexical analyzer

III. The start symbol does not have an inherited attribute

IV. Attribute grammar is a SDD in which function in the semantic rules should produce side effects.

(A) T T T T (B) T F T F (C) T T T F (D) F T T F

3. Consider the following processes with CPU Burst time in ms and the priority given. Assume that all processes have arrived at time 0.

Process	Burst Time (ms)	Priority
P1	8	3
P2	1	1
P3	3	3
P4	2	2
P5	7	4

The processes use priority scheduling algorithm, where low priority number means higher priority. If two processes have same priority number, then the process with lower index gets executed first. The average waiting time (in ms) of the processes is

(A) 4.5 (B) 5.8 (C) 6.7 (D) 7.1



4. Which of the following is the correct SOP operation for the given circuit?

- (A) $CD + ABC + A'B'D'$
- (B) $ABC + B'CD + A'CD$
- (C) $A'B'D' + ABC + A'CD$
- (D) None of these

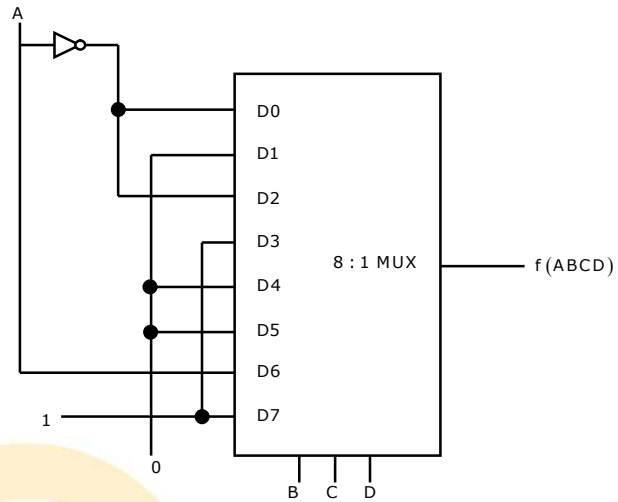

5. Which among the following schedules is an irrecoverable schedule:-

(A)

T1	T2
	R(A)
	W(A)
R(A)	
W(A)	
	Commit
Abort	

(B)

T1	T2
R(A)	
W(A)	
	R(A)
	W(A)
Abort	
	Abort

(C)

T1	T2
R(A)	
W(A)	
Abort	
	R(A)
	W(A)
	Commit

(D)

T1	T2
R(A)	
W(A)	
	R(A)
	W(A)
	Commit
Abort	

6. What would be expectation of number of failures preceding the first success in an infinite series of independent trials with constant probability of success p?

- (A) $\frac{1}{p}$
- (B) $\frac{1}{q}$
- (C) $\frac{q}{p}$
- (D) None of these

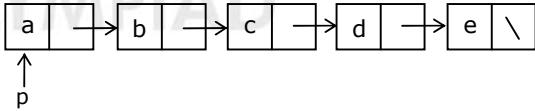

7. The following is a dump of UDP header in hexadecimal format 5EFA00FD001C3297. What is the total length of user datagram? Is the packet from client to server or vice versa?
 (A) 30 bytes and packet is going from client to server
 (B) 28 bytes and packet is going from client to server
 (C) 30 bytes and packet is going from server to client
 (D) 28 bytes and packet is going from server to client
8. Consider a computer system that has a cache with 512 blocks, each of which can store 32 bytes of data. All addresses are byte addresses. Then to which cache line will the memory address $0 \times \text{FBFC}$ map to if the cache is direct mapped and 8 way set – associative respectively.
 (A) DBA, 3C (B) 1DA, 1D
 (C) 1DF, 1F (D) 1CF, 3E
9. Consider the following hashing scheme. Our hash function is $H1 = k \bmod 20$. When collision occurs, we repeatedly compute $H_{n+1} = (H_n + 4) \bmod 20$ until collision resolves and following keys are inserted into the hash table
 45, 25, 10, 5, 9, 30
 Find number of collisions occurred.
 (A) 4 (B) 5 (C) 6 (D) 7
10. Assume that p & q are pointers. What will be the output after performing following sets of operations on a given linked list?
 struct node
 {
 char info;
 struct node *link;
 };

 Operations are:
 $q = p \rightarrow \text{link} \rightarrow \text{link};$
 $p \rightarrow \text{link} = q \rightarrow \text{link} \rightarrow \text{link};$
 $q \rightarrow \text{link} \rightarrow \text{link} \rightarrow \text{link} = q \rightarrow \text{link};$
 $\text{printf}(\text{"\%c"}, p \rightarrow \text{link} \rightarrow \text{link} \rightarrow \text{link} \rightarrow \text{info});$
 (A) e (B) d (C) c (D) b
11. The number of swaps required to sort the numbers 4,3,1,5,2 using bubble sort is
 (A) 2 (B) 3 (C) 4 (D) 6
12. The number of states in minimal DFA which accepts all the strings that contain at least two 0's and at most one 1 over the alphabet $\Sigma = \{0, 1\}$ is
 (A) 4 (B) 5 (C) 6 (D) 7



13. Consider the following function given below:

```

int function(int n)
{
    if(n-1)
        return 2*function(n-1)+n;
    else
        return 0;
}

```

What is the value returned by function (5)?

- (A) 33 (B) 41 (C) 57 (D) 65
14. An operation swap tree takes a binary tree and swaps the left and right children of each node starting from root node. Consider the following binary tree given below.

- (A) $a_7 a_4 a_5 a_2 a_8 a_6 a_3 a_1$
 (B) $a_8 a_6 a_3 a_5 a_7 a_4 a_2 a_1$
 (C) $a_7 a_4 a_5 a_3 a_8 a_6 a_2 a_1$
 (D) $a_7 a_5 a_4 a_3 a_8 a_6 a_2 a_1$

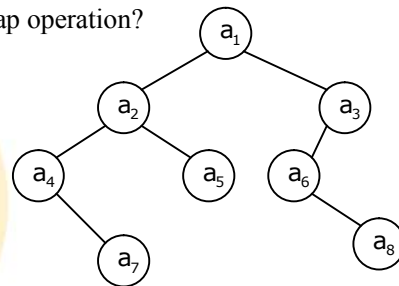

15. Consider the following program fragment:

```

d=0;
for (i=1; i<31; ++i)
    for (j=1; j<31; ++j)
        for (k=1; k<31; ++k)
            if ((i+j+k)%3== 0)
                d = d + 1;

```

printf("%d", d);

The output will be

- (A) 9000 (B) 2700 (C) 3000 (D) none of these
16. A micro programmed control unit has a support of 256 instructions each of which on an average takes 16 micro operations. The system has support of 16 flag conditions and 48 control signals. Horizontal micro programming is used in the system. The length of control word is
- (A) 56 bits/word (B) 64 bits/word (C) 72 bits/word (D) 66 bits/word.

17. Evaluate $\iint xy(x+y) dx dy$ taken over the area between $y = x^2$ and $y = x$.

- (A) 0 (B) 2/56 (C) 1/56 (D) 3/56



18. For the language $L = a^i b^j c^k$, consider the following possible conditions on i, j, k

(C1) $i = j + k$, $i, j, k \geq 0$

(C2) $j = i + k$, $i, j, k \geq 0$

(C3) $k = i + j$, $i, j, k \geq 0$

(C4) $i < j$ & $j < k$, $i, j, k \geq 0$

(C5) $i = j$ & $j < k$, $i, j, k \geq 0$

For which of the above conditions, the language L is not a context-free language?

- (A) C2, C4 only
 (B) C4 and C5 only
 (C) C2, C4 and C5 only
 (D) C3, C4, C5 only
19. The number of articulation points and Bi-connected components for the following graph are respectively

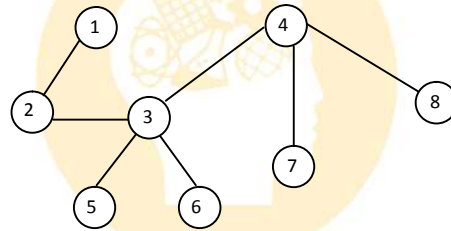

- (A) 4, 5 (B) 3, 4 (C) 3, 7 (D) 4, 4
20. The following grammar is
 $s \rightarrow Aa | bAc | Bc | bBa$
 $A \rightarrow d$
 $B \rightarrow d$
- (A) LR(1) but not LALR(1) (B) LALR(1) but not SLR(1)
 (C) SLR(1) but not LR(0) (D) LR(0)
21. Consider a collection of 20 balls, where each ball has a unique number 1 to 20 printed on it. If we take out 8 balls from this collection at random, then find the expected value of sum of numbers printed on these 8 balls ?
- (A) 84 (B) 92 (C) 78 (D) 66



22. Which of the following Hasse diagram does not represent a lattice?

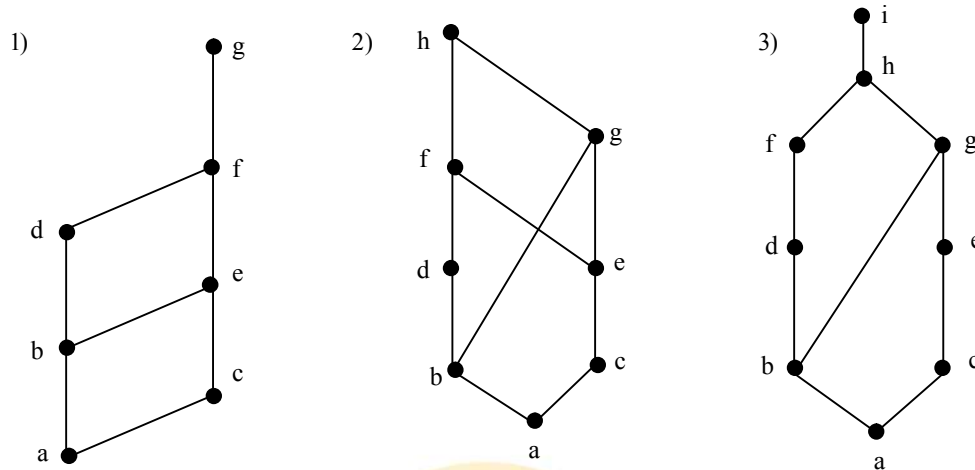

- (A) 1 and 2 (B) 2 and 3 (C) 1 only (D) 2 only.

23. Consider the resource allocation graph:
Which of the processes are in deadlock?

- (A) P1 only
(B) P1 and P2
(C) P1, P2 and P3
(D) The system is deadlock free

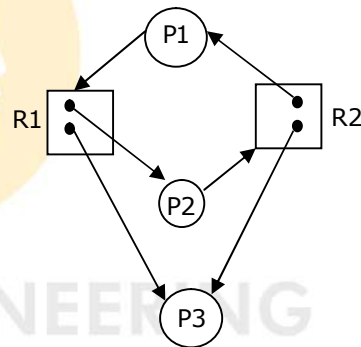

24. The iterative root of $f(x) = 3x^2 + 2x + 1$ using Newton Raphson method is

- (A) $x_{n+1} = \frac{3x_n^2 + 1}{6x_n + 2}$ (B) $x_{n+1} = \frac{9x_n^2 + 4x_n + 1}{6x_n + 2}$
(C) $x_{n+1} = \frac{3x_n^2 - 1}{6x_n + 2}$ (D) $x_{n+1} = \frac{9x_n^2 - 4x_n - 1}{6x_n + 2}$

25. Consider a table $R(A, B, C, D, E)$ with functional dependencies as

- $A \rightarrow B$
 $B \rightarrow C$
 $D \rightarrow E$

Table is decomposed as $D = \{R_1(A, B), R_2(B, C), R_3(D, E)\}$. Then decomposition is

- (A) Dependency preserving and lossless
(B) Dependency preserving and lossy
(C) Neither dependency preserving nor lossless
(D) Not dependency preserving but lossless



26. The number of nodes if we construct the B+ tree with order (internal node) = 3 and order (leaf node) = 2 for the sequence of keys "5, 8, 1, 7, 3, 12, 9, 6." is
(A) 5 (B) 9 (C) 7 (D) 8
27. To implement $A + BC$, minimum number of NAND & NOR gates used respectively is
(A) 3, 3 (B) 3, 4 (C) 4, 3 (D) 3, 5
28. A 16kB cache with line size 64B uses 4-way set associative mapping. Main memory is 8 MB and byte addressable. The size of extra space needed for storing tag information in bytes is
(A) 294 (B) 352 (C) 386 (D) 312
29. An Ethernet LAN has transmission delay of 10ms and propagation delay from one station to another is 2ms. The system is operating on a 5kbps bandwidth. Find channel efficiency in percentage .
(A) 48 (B) 56 (C) 42 (D) 62
30. Which of the following multiplier pattern of booth's algorithm gives the better performance?
(A) 01111111110 (B) 111110001111
(B) 011111011111 (D) 111111111000



INDIAN ENGINEERING
OLYMPIAD