

Q.1. (A) Answer the following the short. (05)

1. Express kinetic energy of SHO at $y=A/4$ position in terms of its total mechanical energy.
2. What is importance of phase?
3. The equation of a stationary wave is given by $y = -8 \sin\left(\frac{\pi x}{2}\right) \cos(20\pi t)$
Find the wavelength of component wave. Here y is in meter.
4. Write MKS unit of resistive constant of the medium.
5. On what factors does the position of the centre of mass of a rigid body depend?

(B) Answer the following. (any three) (06)

1. Write differential equation for damped oscillations. Discuss its solution along with the graph.
2. Obtain the equation for a one dimensional harmonic progressive wave.
3. Discuss reflection of wave from a rigid support.
4. In the expression $Ma_{cm} = F$, only external forces acting on the system of particles should be taken into account, explain with an appropriate example.

(C) Solve the following. (any three) (09)

1. A given mass executing SHM has frequency equal to 50 Hz. At a particular instance its KE and PE are 1.0 J and 0.85 J. If amplitude of oscillation is 0.06 m. Find the value of mass?
2. Initial displacement of a damped oscillation is zero; and its initial velocity is v_0 . Obtain the values of the constants in the expression for its displacement. Take angular frequency as ω .
3. Two wires placed close to each other are vibrating in their first harmonic. If the length of wires are 20.4 cm and 20 cm and the velocity of wave in the wires is 200 ms^{-1} , find the number of beats produced.
4. Distance between two particles having masses m_1 and m_2 is r . If the distances of these particles from the centre of mass of the system

are respectively are r_1 and r_2 . Show that : $r_1 = r \left[\frac{m_2}{m_1 + m_2} \right]$ and

$$r_2 = r \left[\frac{m_1}{m_1 + m_2} \right]$$

Q.2. (A) Answer the following in short. (05)

1. Radial and tangential components of acceleration of a particle of rigid body change the and the of linear velocity of the particle. Fill in the blanks.
2. Write dimensional formula of areal velocity.
3. If the ratio of range to maximum height for a projectile is $4\sqrt{3}$. What is the angle of projection?
4. Write the relation between temperature and volume for a gas undergoing adiabatic change.
5. The emissive power of two substance are in the ratio of 16:1. If the substance with higher emissive power is at 527°C . What is the temperature of the other substance?

(B) Answer the following (any three) (06)

1. Explain angular momentum of a particle.
2. Why roads are banked? Draw the necessary diagram and describe forces acting on a vehicle moving through a banked road. Write the expression for the maximum safe velocity on a horizontal curved road?
3. Obtain the expression for acceleration due to gravity at a distance r ($r > R_e$) from the centre of the earth. Obtain an expression for the changes in its value with the height.
4. What is cyclic process? Write first law of thermodynamics for its and obtain expression for its efficiency.

(C) Solve the following (any three) (09)

1. The second hand of a watch is 5 cm long. Find
(a) linear velocity (b) the radial acceleration
(c) the tangential acceleration
2. A metallic disc has radius 10 cm. and thickness 1 cm Find its moment of inertia about

an axis which is perpendicular to its plane and touching the edge.

Density of material is 8900 kg/m^3 (Thickness of disc = 1 cm)

3. The escape velocity for a body at earth's surface is 11.2 kms/sec. If a body is projected with a velocity 2 times this velocity, obtain its velocity beyond earth's gravitational field.
4. An ideal gas is isothermally expanded so that its volume becomes double. Then it is adiabatically compressed to its original volume. Find the pressure after the adiabatic compression.
(Original pressure = 1 atmosphere; $\gamma = 1.4$)

Q.3. (A) Answer the following in short. (05)

1. A 5Ω and 10Ω resistances are connected in parallel, if current passing through 10Ω resistance is 2 ampere. What is total current through the circuit. (Parallel combination is connected to a battery of negligible internal resistance)
2. A 40 W and a 60 W bulb, both rated at the same voltage are joined in parallel. Which bulb will glow more?
3. An electron revolves along a circle of radius r with velocity v , what is magnetic field created at the centre.
4. Terminal voltage of a cell is always less than its emf. State true or false with reason.
5. Define henry.

(B) Answer the following. (any three) (06)

1. Show that for a parallel combination of three resistances,
$$\frac{1}{R} = \frac{1}{R_1} + \frac{1}{R_2} + \frac{1}{R_3}$$
. Where R is equivalent resistance.
2. Draw schematic diagram of fuel cell and name oxidiser and fuel in it and also give advantage of it over other cells.
3. Define shunt and give any three uses of it in construction of an ameter.
4. Write a note on "self induction".

(C) Solve the following (any three) (09)

1. A conducting wire has a resistance of 20 ohms. Its length is now stretched to increase by 4%. Calculate the resulting value of the resistance of the wire.

2. A battery having an emf E and an internal resistance r is connected with a resistance R . Prove that the power in the external resistance R is maximum when $R = r$.
3. A very long straight wire carries a current of 50 amp. At what distance from this wire will the intensity of the magnetic field become 2.0×10^{-4} tesla?

$$\left\{ \mu_0 = 4\pi \times 10^{-7} \frac{\text{tesla} \cdot \text{m}}{\text{Ampere}} \right\}$$

4. A rectangular coil 20 cm long and 10 cm wide is suspended such that its area vector makes an angle 60° with the uniform magnetic field of intensity 20 tesla. If the coil has 100 turns and current of 5 mA is passing through it. Calculate the torque. Also find the maximum torque at an appropriate inclination.

Q.4. (A) Answer the following in short. (05)

1. What will be power factor of an AC circuit having only a capacitor?
2. What will be phase difference in a L-C-R series AC circuit at resonance frequency?
3. What is modulation?
4. Define plane polarised light.
5. What is red shift?

(B) Answer the following (any three) (06)

1. What is formula for impedance of L-C-R series AC circuit? Represent it on the complex plane.
2. Explain arrangement of Hertz experiment with necessary diagram and how circuit is formed oscillatory circuit?
3. Giving necessary figure, obtain the condition for the m^{th} order maximum in Fraunhofer diffraction at single slit.
4. Draw the figure showing plane of oscillation and plane of polarization and define them.

(C) Solve the following (any three) (09)

1. L-R series circuit is connected to a source of A.C. voltage. The maximum voltage of the source is 220 V and maximum current is 1A. Find the power and power factor. Reactance of the coil is 40Ω and $R=30\Omega$.

2. An A.C. supply of 150 V and 159.2 Hz frequency is connected to an inductance of 2H. Obtain the equation for the current in the circuit. The applied voltage $V = V_m \cos \omega t$.
3. In Young's experiment, if the separation of the slits is 0.1 mm and the light used is of 6000 Å wave length. Find the angular distance between the central fringe and the second bright fringe.
4. A parallel beam of light is incident normally on a slit of width 0.01 cm. Its Fraunhofer diffraction pattern is formed with a lens of 100 cm focal length on a screen. If the width of central maximum is 1 cm, find the wavelength of incident light.

Q.5. (A) Answer the following questions in very short. (05)

1. Express 5eV (electron-volt) energy in Erg.
2. What is the atomic mass unit (amu)?
3. What is multiplication factor?
4. Mention two uses of transistor.
5. Draw the circuit of half wave rectifier.

(B) Answer the following (any three) (06)

1. Mention limitations of the Bohr model.
2. Write exponential law of radio active disintegration. Obtain the expression for half life time from it.
3. What is nuclear chain reaction? Name three necessary precautions that have to be taken to get a sustained chain reaction.
4. Draw the circuit of a PN Junction in forward bias. Explain the working and diode characteristic of PN junction in forward bias.

(C) Solve the following (any three) (09)

1. How many photons of 6000 Å wavelength of light will have the energy equal to energy of one gamma ray photon of 1.5×10^{14} m wavelength?
2. Half life of a radioactive element is 15 minutes. Find after what time its velocity becomes 64^{th} of the initial activity.
3. In a hydrogen atom, the frequency of an electron in an orbit of quantum number n is given by $f = \frac{me^4}{4\epsilon_0^2 n^3 h^3}$. Prove that for large values of quantum number n , the radiation emitted in transition from

a level (n+1) to a level n has the same frequency $R = \frac{me^4}{8\epsilon_0^2 ch^3}$.

4. In an NPN transistor when emitter current is 5mA, collector current is 4.9 mA. If this transistor is used as common base, calculate the current gain and also the current gain when it is used as common emitter.

SOLUTION

A.1. (A) 1. P.E. = $\frac{1}{2}ky^2 = \frac{1}{2}k\left(\frac{A}{4}\right)^2 = \frac{1}{16}\left(\frac{1}{2}kA^2\right) = \frac{E}{16}$

$$\therefore K.E. = E - \frac{E}{16} = \frac{15}{16}E$$

2. To find position of reference particle and no. of revolutions completed by it to reach that position also to find position of SHO and no. of oscillations completed by it before reaching to that position, phase is defined.

3. $y = -8\sin\left(\frac{\pi x}{2}\right)\cos(20\pi t)$

$$k = \frac{\pi}{2},$$

$$\text{But } k = \frac{2\pi}{\lambda} = \frac{\pi}{2}$$

$$\therefore \lambda = 4m$$

4. $F = -bv$

$$\therefore b = \frac{F}{v}$$

$$\therefore \text{unit of } b = \frac{\text{Newton} - \text{sec}}{m}.$$

5. It depends on (i) shape of the body (ii) distribution of mass.

- (B) 1. When ever a body performs oscillations in a fluid medium, resistive force of the medium acts on the oscillator. For not very large velocities, the resistive force (F_v) is found to be directly proportional to the velocity. i.e. $F_v = -bv$ where b is a constant and is called the damping coefficient of the medium.

Thus in practice a body oscillates under the influence of two forces:

(i) restoring force = $-k.y$. and (ii) resistive force $F_v = -b.v = -b\frac{dy}{dt}$

Then from Newton's 2nd law of motion $m\frac{d^2y}{dt^2} = -ky - b\frac{dy}{dt}$

$$\frac{d^2y}{dt^2} + \frac{b}{m}\frac{dy}{dt} + \frac{k}{m}y = 0 \dots (1)$$

Equation (1) is called the differential equation of a damped oscillations.

Solution of equation (1) is :

$$y_{(t)} = Ae^{-\frac{bt}{2m}} \sin(\omega't + \phi) \dots (2)$$

where $\omega' = \sqrt{\frac{k}{m} - \left(\frac{b}{2m}\right)^2}$ (3)

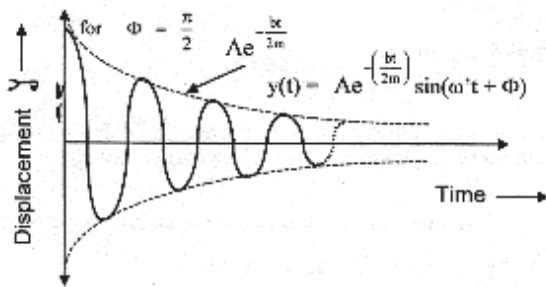

Equation shows that at any time 't' the amplitude of such oscillations is $A(t) = Ae^{-\frac{bt}{2m}}$ i.e. the amplitude decreases exponentially with increase in time.

The graph of displacement $y(t) \rightarrow t$ for such an oscillator is shown in the figure. The dotted line shows decrease in amplitude with increase in time.

2. Consider particles of one dimensional elastic medium, at rest as shown in figure below.



Now at $t=0$ suppose a disturbance is produced in such a way that particle at $x=0$ starts its S.H.M. about its mean position with amplitude A and angular frequency ω . Here obviously $\phi = 0$, hence equation of displacement of particle at $x=0$ is given by.

$$y = A \sin(\omega t)$$

When the wave travels distance x , then particle P starts performing S.H.M. The phase of successive particles decreases as we go in direction of propagation.

Hence at any time the phase of particle P is less than the phase of O . The phase difference is say δ . The equation of displacement of P can be written as,

$$y = A \sin(\omega t - \delta) \dots (1)$$

For distance between two particles equal to λ , phase difference is 2π so for distance x between two particles phase differences is equal

$$\text{to } \delta = \frac{2\pi x}{\lambda}.$$

.....(2)

taking in equation (1)(3)

3. Consider a one-dimensional elastic string tied from one end with a rigid support at $x=0$ as shown in fig.1. Suppose a progressive harmonic wave travelling in negative x direction arrives at $x=0$. The incident wave is represented by



Displacement of particle at $x=0$ due to the incident wave is given by,

$$y_i = A \sin(\omega t) \dots(1)$$

But since this particle is firmly tied with the rigid support its displacement is always zero. Now wave is reflected. If ' y_r ' is the displacement of the particle at $x=0$ due to reflected wave then

$$y_i + y_r = 0 \text{ hence } y_i = -y_r \cdot y_r = -A \sin(\omega t)$$

OR

$$y_r = A \sin(\omega t + \pi) \dots(2)$$

From equation (2) it is clear that on reflection from a rigid support phase of the wave increases by π .

Thus after reflection from a rigid support the crest becomes trough and vice versa.

For any other particle on the wave, the displacement due to reflected wave can be given by

$$y_r = A \sin(\omega t + \pi - kx) = -A \sin(\omega t - kx)$$

4. Two types of forces act on a system (i) external and (ii) internal forces of mutual interaction having same magnitude but opposite direction. According to Newton's third law of motion, internal forces acting among the particles are equal in magnitude and opposite in direction hence resultant of all the internal forces becomes zero. This can be easily understood with the help following example.

Consider two particles of a system. Suppose \vec{F}_{1ext} and \vec{F}_{2ext} are the particle 1 and particle 2 external forces acting on the two

particles respectively as shown in fig. 1. Also suppose \vec{F}_{12} and \vec{F}_{21} are the forces of mutual attraction. All these forces can be considered to be acting on the center of mass of the system of particles as shown in fig.2.

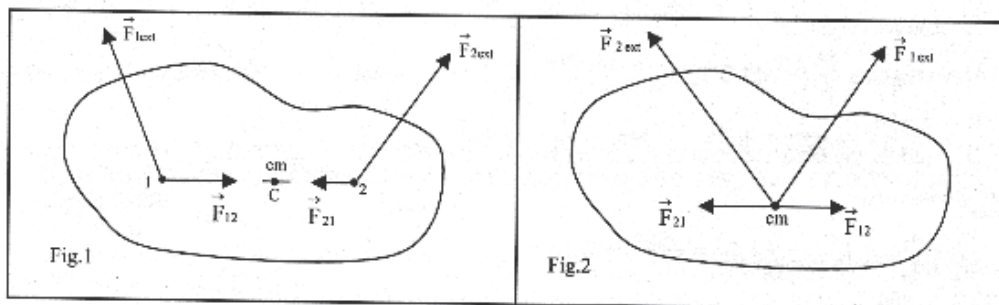

It is clear from fig.2 that $\vec{F}_{21} + \vec{F}_{12} = 0$. Thus resultant force acting on the system is the vector sum of only external forces.

For a single particle Newton's 2nd law can be written independently of 3rd law of motion. But from above discussion it is clear that in order to derive Newton's second law of motion for a system of particles, we have to make use of Newton's third law of motion. This is known as mutual dependence of Newton's laws of motion.

(C) 1. Given Frequency $f = 50 \text{ Hz}$;

$$\therefore \omega = 2\pi f = 100\pi \text{ rad/sec.}$$

But M.E. = K.E. + P.E.

$$E = 1.0 + 0.85 = 1.85 \text{ J.}$$

$$A = 0.06\text{m.}$$

But

2. For a damped oscillator, (1)

here at

from equation (1),

Using this value of in equation (1),

$$\therefore v_{(t)} = \frac{dy_{(t)}}{dt} = Ae^{-\frac{bt}{2m}} \omega' \cos(\omega' t) + A \left(-\frac{b}{2m} \right) e^{-\frac{bt}{2m}} \sin(\omega' t)$$

but at $t = 0$, $v_{(t)} = v_0$, hence from above equation,

$$v_0 = Ae^0 \omega' \cos(0) + A \left(-\frac{b}{2m} \right) e^0 \sin(0)$$

$$\therefore v_0 = A \omega' \Rightarrow A = \frac{v_0}{\omega'}$$

3. Here, $v = 200$ m/s,

$$L_1 = 20 \times 10^{-2} \text{m},$$

$$L_2 = 20.4 \times 10^{-2} \text{m}$$

Let number of beats = x .

$$f_1 - f_2 = x.$$

$$\therefore x = \frac{v}{2L_1} - \frac{v}{2L_2} = \frac{v}{2} \left(\frac{1}{L_1} - \frac{1}{L_2} \right) \quad \left(\because f = \frac{v}{2L} \right)$$

$$x = \frac{500}{51} \approx 10 \text{ beats.}$$

4. Given $r = r_1 + r_2 \dots\dots (1)$

If origin is taken on the centre of mass then $r_{cm} = 0$. Hence from

equation $\vec{r}_{cm} = \frac{m_1 \vec{r}_1 + m_2 \vec{r}_2}{m_1 + m_2}$ we get

$$0 = \frac{m_1 \vec{r}_1 + m_2 \vec{r}_2}{m_1 + m_2} \Rightarrow m_1 \vec{r}_1 + m_2 \vec{r}_2 = 0 \Rightarrow m_1 \vec{r}_1 = -m_2 \vec{r}_2,$$

(neglecting negative sign)

Now by doing componendo

and by using dividendo

A. 2 (A)

1. Radial and tangential components of acceleration of a particle of rigid body change the direction and the magnitude of linear velocity of the particle.

2. Areal velocity = $\frac{dA}{dt} = M^0 L^2 T^{-1}$.

3. $R = \frac{v_0^2 \sin 2\theta}{g}$

and

$$H = \frac{v_0^2 \sin \theta}{2g}$$

$$\therefore \frac{R}{H} = \frac{\sin 2\theta}{\frac{\sin^2 \theta}{2}} = \frac{4}{\tan \theta} = 4\sqrt{3}$$

$$\therefore \tan \theta = \frac{1}{\sqrt{3}}$$

$$\therefore \theta = 30^\circ$$

4. $TV^{\gamma-1} = \text{constant}$.

5. $\frac{W_1}{W_2} = \frac{T_1^4}{T_2^4}$

$$\therefore T_1^4 = \frac{W_1}{W_2} \times T_2^4 = \frac{1}{(2)^4} \times (800)^4$$

$$(\because T_2 = 527 + 273 = 800^\circ K)$$

$$T_1 = \frac{800}{2} = 400^\circ K \quad \therefore T_1 = 400 - 273 = 127^\circ C.$$

(B) 1. As shown in figure suppose a particle Q having mass m has a position vector \vec{r} , with reference to a point O. Let \vec{v} be the linear velocity of this particle, so that its linear momentum is $\vec{p} = m\vec{v}$. Let θ be the angle between \vec{r} and \vec{p} . For convenience, we shall assume that the motion of the particle is in the (x,y) plane. The vector product of \vec{r} and \vec{p} is then defined as the angular momentum \vec{L} of the particle with reference to point O; i.e.

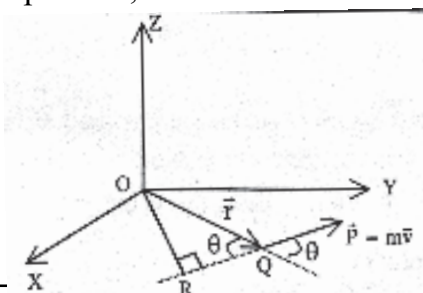

$$\vec{\ell} = \vec{r} \times \vec{p}$$

Unit of $\vec{\ell}$ is kg-m²/s

(i) Direction of the vector $\vec{\ell}$ is obtained by applying the right hand screw rule to the vector product $\vec{r} \times \vec{p}$. In the case illustrated, $\vec{\ell}$ is directed along OZ.

(ii) The magnitude of $\vec{\ell}$ is $rp \sin \theta$. If θ is either 0 or π ; i.e. the line of action of \vec{p} pass through the reference point O; or if $r=0$, then the angular momentum is zero. When defining the angular momentum, one must specify the point about which it is taken.

2. When a vehicle moves on a curved path, the necessary centripetal force $\left(\frac{mV^2}{r}\right)$ is obtained from the frictional forces between the tyres and the road. For more speed at turns, sometimes such centripetal force may not be sufficient and the vehicle is thrown off the road. Hence to provide more centripetal force the roads are kept slightly inclined (banked) at the turn.

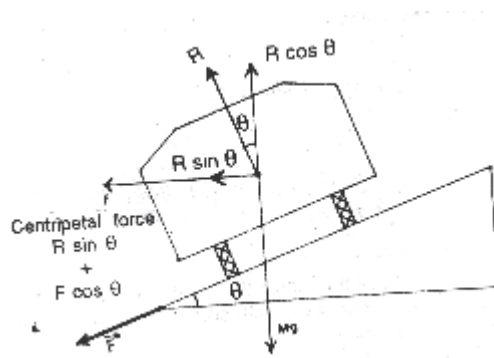

Figure shows the cross-section of a curved road having radius of curvature "r" and an angle of inclination θ across the road.

Let us assume that the maximum safe speed is v.

Following forces are acting on the vehicle.

- (1) Weight of the vehicle Mg acting downwards.
- (2) Force of the normal reaction R acting perpendicular to the surface of the road, i.e. at an angle θ to the vertical.
- (3) Force of friction F acting parallel to the surface of the road.

For maximum safe velocity on a horizontal curved road is $v = \sqrt{rg}$.

3. Acceleration produce in a body due to gravitational force of the earth on it is called gravitational acceleration.

Let mass of earth be M_e and its radius be R_e .

Let m = mass of a body and its distance from the center of the earth r ($r > R_e$) then from Newton's law of gravitation the gravitational force acting on the body due to the earth is,

$$F = G \frac{M_e m}{r^2} \dots\dots(1)$$

But according to Newton's 2nd law of motion.

$$F = mg \dots\dots(2)$$

From (1) and (2) $mg = G \frac{M_e m}{r^2}$ $g = \frac{GM_e}{r^2} \dots\dots(3)$

Differentiating above equation with respect to r , $\frac{dg}{dr} = \frac{-2GM_e}{r^3}$

$$\therefore dg = -2 \frac{GM_e}{r^2} \frac{dr}{r} = -2g \frac{dr}{r}.$$

4. Cyclic Process : "In heat engine, the working substance, starting from specific equilibrium state, is allowed to undergo a series of changes and brought back to its original state." Such a process is called Cyclic proces..

In cyclic process, since initial and final states are same, at the end of the cyclic process change in internal energy ($\Delta U = U_2 - U_1$) is zero.

Thus from the 1st law of thermodynamics, $Q = (U_2 - U_1) + W$ thus $Q=W$ $\dots(1)$

Now the heat lost Q_2 into the sink is of no significance hence work can be said to be done at the cost of heat Q_1 . Therefore efficiency of any heat engine based on cyclic process per cycle is defined as,

$$\dots(3)$$

But here

Substituting the value of W from equation,

(C) 1. Give $r = 5\text{cm}$,

(a) $/\text{sec}$

(b) radial acceleration = $a_r = \frac{v^2}{r} = \omega^2 r = \frac{\pi^2}{900} \times 5 \approx 0.0548 \frac{cm}{sec^2}$

(c) tangential acceleration = 0 as $\omega = \text{constant}$.

2. $r = 10\text{cm} = 10^{-1}$ meter,

thickness of disc $x = 1 \text{ cm} = 10^{-2}$ meter,

Density $\rho = 8900 \text{ kg/m}^3$.

$$I = \frac{MR^2}{2} + R^2 = \frac{3}{2} MR^2$$

$$M = V\rho = \pi R^2 x \rho = \pi (10^{-1})^2 \times 10^{-2} \times 8900 \text{ kg}$$

$$\therefore I = \frac{3}{2} \pi R^4 \times \rho = \frac{3}{2} \times 3.14 \times 10^{-4} \times 10^{-2} \times 8900 = 4.19 \times 10^{-2} \text{ kgm}^2$$

3. Suppose the body is projected with a velocity v . Its kinetic energy at the surface of earth is $= \frac{1}{2} mv^2$. Its potential energy at the surface of

earth is $-\frac{GM_e m}{R_e}$ and $\frac{GM_e m}{R_e} = \frac{1}{2} mv_e^2$

$$\therefore \text{Its total energy on the surface of the earth is } = \frac{1}{2} mv^2 - \frac{GM_e}{R_e}. \quad (1)$$

Now on leaving gravitational field of the earth velocity is v' ,

so kinetic energy will be $\frac{1}{2} mv'^2$.

4. Original

...(1)

$$p_1 V_2^\gamma = p_3 V_3^\gamma$$

$$\therefore p_2 2^\gamma V_1^\gamma = p_3 V_1^\gamma$$

$$\therefore p_2 2^\gamma = p_3$$

$$\therefore \frac{p_1}{2} \cdot 2^\gamma = p_3$$

$$\therefore p_1 2^{\gamma-1} = p_3$$

$$\therefore \log p_1 + (\gamma - 1) \log 2 = \log p_3 \quad \therefore (1.4 - 1) \log 2 = \log p_3$$

$$\therefore (0.4)(0.3010) = \log p_3 \quad \therefore 0.1204 = \log p_3$$

$$\therefore p_3 = \text{Antilog } 0.1204 = 1.319 \text{ atmosphere.}$$

- A.3 (A) 1. $I_1 R_1 = I_2 R_2$
 $\therefore 5I_1 = 10 \times 2$
 $\therefore I_1 = 4\text{A}$
2. 60W bulb will glow more as power consumed in it is more.
3. $B = \frac{\mu_0 e v}{4\pi r^2}$.
4. False, when a cell is charged terminal voltage becomes more than emf.
 $[V = E + Ir]$.
5. If $\frac{dI}{dt} = 1 \frac{\text{amp}}{\text{sec}}$ and induced emf 1 volt, the self inductance of the circuit is 1 Henry.

- (B) 1. In parallel connection one end of all the resistances meet at one point and other end at another common point.
 Suppose three resistances R_1 , R_2 and R_3 are connected in parallel and potential difference V is applied across them by connecting a battery.

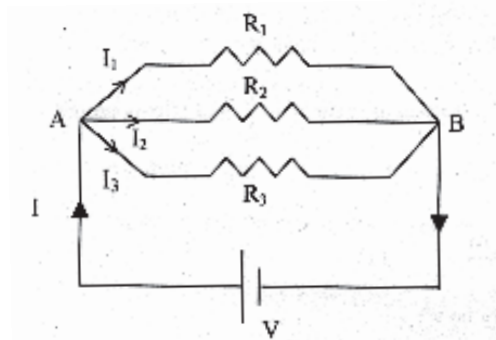

Let I = the electric current passing through the battery. At point A this current divides into three branches.

Let I_1 , I_2 and I_3 be the currents passing through resistances R_1 , R_2

and R_3 respectively, then by applying Kirchoff's first law at junction A, $I = I_1 + I_2 + I_3 \dots(1)$

Now applying Kirchoff's 2nd law in loops V-A- R_1 -B-V, V-A- R_2 -B-V, V-A- R_3 -B-V respectively we get,

$$I_1 = \frac{V}{R_1}$$

Similarly $I_2 = \frac{V}{R_2}$ and $I_3 = \frac{V}{R_3}$ substituting these values in equation (1),

$$I = \frac{V}{R_1} + \frac{V}{R_2} + \frac{V}{R_3} \Rightarrow \frac{I}{V} = \frac{1}{R_1} + \frac{1}{R_2} + \frac{1}{R_3}$$

If parallel combination of R_1 , R_2 and R_3 is replaced by a single resistance R such that the current passing through the circuit remains the same then it is called equivalent resistance of the combination.

If R is the equivalent resistance of the circuit then according to

the Ohm's law, $\frac{I}{V} = \frac{1}{R}$ Using this in equation (2)

$$\frac{1}{R} = \frac{1}{R_1} + \frac{1}{R_2} + \frac{1}{R_3}$$

For n such resistances in parallel $\frac{1}{R} = \sum \frac{1}{R_i}$.

2. Construction of Hydrogen - Oxygen fuel cell is shown in fig.

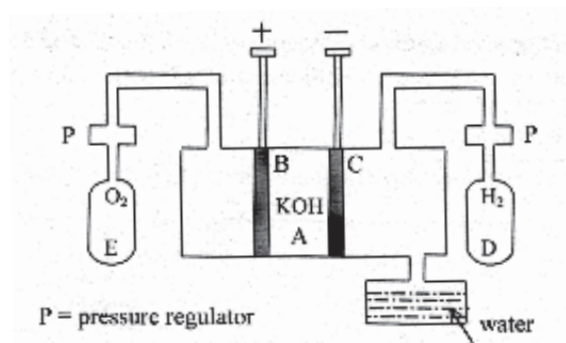

Fuel cell is a type of an electrochemical cell. A schematic diagram of a fuel cell using hydrogen as a fuel and oxygen as an oxidiser is shown in the figure.

Advantage: In this cell it is not necessary to change chemical substance like primary cells or to recharge the cell as in case of secondary cells.

3. A small resistance connected in parallel with a galvanometer to convert it in an ammeter is called shunt.

Uses:

- (1) It protects galvanometer
- (2) By connecting shunt, range of the ammeter can be increased
- (3) When shunt is connected resistance of the ammeter is decreasing so we can measure almost exact current.

4. Lenz's Law: If an agency generates an induced emf through its action (such as motion of the magnet) the induced emf would be such that the current produced by this emf would generate a magnetic field such as to oppose the action of the agency.

Faraday's Law: The negative time rate of change of magnetic flux linked with a circuit is equal to the induced emf in the circuit.

(C) 1. $R_1 = 20\Omega$,

$$\frac{dR}{R} \times 100 = 2 \left(\frac{dl}{l} \times 100 \right)$$

so change in resistance is 8% so increase in resistance is $\frac{20 \times 8}{100} = 1.6\Omega$

so final resistance will be 21.6Ω

2. Power in the external resistance = I^2R .

$$P = \left(\frac{\epsilon}{R+r} \right)^2 R$$

$$\frac{dP}{dR} = \frac{-2\epsilon^2 R}{(R+r)^3} + \frac{\epsilon^2}{(R+r)^2} = 0$$

(being the condition for maximum or minimum P)

$$\therefore R = r$$

3. Here $I=50$ Amp.

$$B = 2.0 \times 10^{-4} \text{ T,}$$

$$y = ?$$

$$\mu_0 = 4\pi \times 10^{-7} \frac{T \times m}{\text{Amp.}}$$

$$\therefore B = \frac{\mu_0 I}{2\pi y}$$

$$\therefore 2 \times 10^{-4} = \frac{4\pi \times 10^{-7} \times 50}{2\pi \times y}$$

$$\therefore y = 5\text{cm}$$

4. Here $A = l \times b = 20 \times 10 = 200 \text{ cm}^2$,

$$A = 200 \times 10^{-4} \text{ m}^2$$

$$\theta = 60^\circ,$$

$$B = 20 \text{ web / m}^2$$

$$N = 100,$$

$$I = 5 \times 10^{-3} \text{ A},$$

$$\tau = ?,$$

$$\tau_{\text{max}} = ?$$

$$\tau = BINA \sin \theta = 20 \times 5 \times 10^{-3} \times 100 \times 200 \times 10^{-4} \sin 60^\circ = 2 \times 10^{-1} \times \frac{\sqrt{3}}{2}$$

$$\therefore \tau = 0.173 \text{ Nm}.$$

when $\theta = 90^\circ$,

$$\tau_{\text{max}} = BINA \therefore \tau_{\text{max}} = 20 \times 5 \times 10^{-3} \times 100 \times 200 \times 10^{-4}$$

$$\therefore \tau_{\text{max}} = 0.2 \text{ Nm}.$$

Q.4. (A) 1. Power factor $\cos \delta = 0$ as $\delta = -\frac{\pi}{2}$ rad.

2. Phase difference, $\delta = 0$. $\left(\because \omega L - \frac{1}{\omega C} = 0 \right)$

3. The technique of impressing the audio waves on the radio frequency waves is called the modulation, and the radio waves which carry the modulation are called the carrier waves.

4. The beam of light in which the electric field intensity vectors (\vec{E}) are oscillating along a fixed direction is called a plane polarized light beam.

5. In the spectrum (due to some of its element) of a star moving away from the earth is observed, the lines in the spectrum would appear at frequencies which are lower than that observed for the same element in the laboratory, due to the Doppler shift; i.e. the lines would appear shifted to the red side of the spectrum. This is called the "red shift".

(B) 1. Complex impedance of L-C-R series A.C. circuit is given by equation.

.....(1)

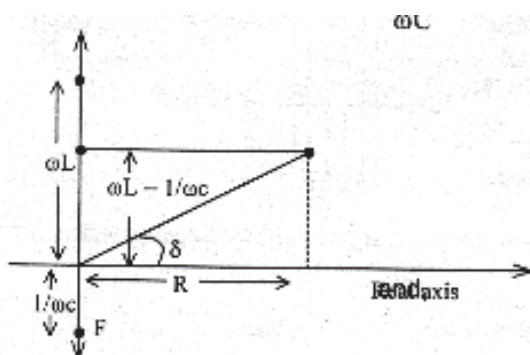

Real part of this resistance is R which is taken on the real axis in the complex plane and it is represented by OD in the figure.

In figure, $OA = \omega L$ and $OF = \frac{1}{\omega C}$ are taken on the imaginary axis of the complex plane.

In figure, $OG = \omega L - \frac{1}{\omega C} =$ imaginary part of Z .

Point H in the fig. represents the complex number Z in the complex plane.

$$|Z| = \sqrt{R^2 + \left[\omega L - \frac{1}{\omega C} \right]^2} \dots (2)$$

Equation (2) give the magnitude of the impedance.

By following the same method δ and Z can be determined for any A.C. circuit.

- Hertz demonstrated production of such waves in laboratory. His arrangement is schematically shown in figure.

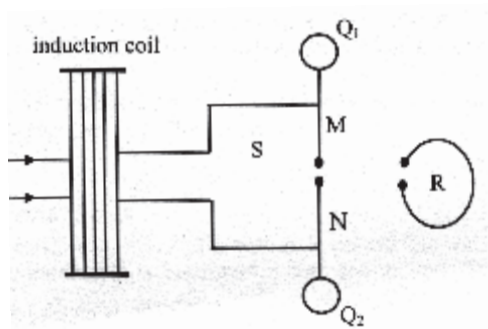

Here, Q_1 and Q_2 are two metallic spheres. Joined to them are two metallic rods M and N with some space between called spark gap S . The rods are connected to the two terminals of an induction coil to provide high intermittent voltage. The spheres Q_1 and Q_2 act as capacitors and the rods act as inductors. This arrangement therefore, acts as an oscillating circuit in which alternately Q_1 and Q_2 acquire positive and negative charge which reverse in their polarity each time a spark passes across the gap S .

- In figure the rays going parallel to each other in a direction making angle with $X P_0$ are shown. These rays converge at point P_2 by a convex lens.

Draw $AM \perp BL$. Consider points X and X' trisecting AB. Thus $AX = d/3$.

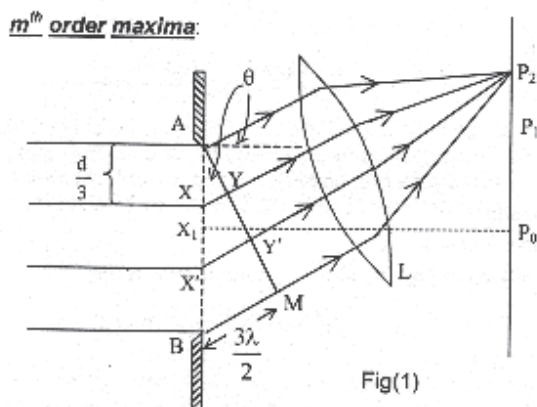

It is clear from the figure that the path difference between the rays emerging from A and X and reaching P_2 is XY . Now suppose that the angle θ is such that $XY = \lambda/2$ then $X'Y' = \lambda$ and $BM = 3\lambda/2$. Thus at P_2 the path difference between the rays coming from A and X is $\lambda/2$ and they interfere destructively. Similarly corresponding to every point in section AX, we can find a point in section XX' such that the path difference between the rays emerging from them is $\lambda/2$. Thus they nullify each other. But the effect of $X'B$ section is not nullified hence there is some intensity of light at point P_2 which is very much less than at P_0 . Point P_2 is called first maximum.

Now from fig., $m \angle BAM = \theta$ hence from, ΔAMB

=

Similarly for m^{th} order maxima we can show that,

where $m=1,2,3,\dots$

- Plane of oscillations (vibration): The plane containing the direction of the beam and the direction of oscillations of the vectors is called the plane of oscillations. In the figure abcd is the plane of oscillations.

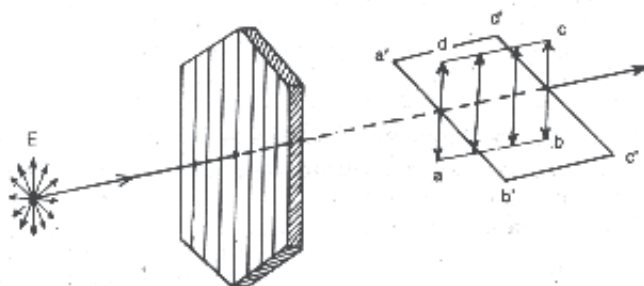

5.

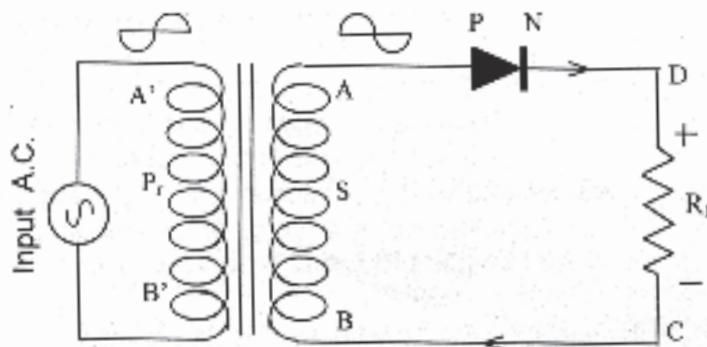

- (B) 1. i) If a single line of hydrogen spectrum is observed with a more powerful spectrometer, it appears to be consisting of more than one lines. This can not be explained by Bohr's model.
- ii) The theory gives no idea about the intensity of spectral lines.
- iii) Electrons are considered to be moving in circular orbits which is not necessary. Electrons can also move in elliptical orbits.
- iv) The theory combines principles of quantum physics and classical mechanics which do not match with each other.

2. $N = N_0 e^{-\lambda t}$

N = number of nuclei, which have not disintegrated at time t ,

N_0 = The number of nuclei of the element not disintegrated at $t = 0$ time,

λ = Decay constant for radioactive element,

e = base of natural log

when $t = \frac{\tau_{1/2}}{2}$, $N = \frac{N_0}{2}$ where N_0 = number of nuclei present at $t = 0$.

Substituting above values in the exponential law, $N = N_0 e^{-\lambda t}$

3. The fission of a uranium nucleus is affected by a single neutron, but more than one neutrons are released as a result of fission of a single nucleus. Under favourable circumstances, these neutrons can affect further fissions in more uranium nuclei; and thus such a fission reaction can progress as a self sustaining chain. The energy released through such a chain reaction under controlled conditions is the source of

nuclear energy in a nuclear reactor. The important points to be taken care of is given below.

(1) The neutrons which are released during the fission are fast neutrons, and can escape from the volume of the reacting mass without initiating further fissions. To slow down the neutrons materials known as "moderators" are used in the nuclear reactors. Heavy water (D_2O), carbon in the form of graphite, Beryllium and ordinary water are used as moderators. To confine the neutrons to the reaction region, neutron reflecting surface are used.

(2) For the chain reaction to proceed in an uninterrupted manner, a definite mass of fissile material (material which undergoes fission) is required, which is called its "critical mass". If the mass exceeds the critical mass, the reaction may proceed too fast and can go out of control.

4. Forward bias:

Suppose the P-side of the junction is connected to the positive terminal of a battery and the N-side is connected to its negative terminal, as shown in the figure. This is called forward bias connection.

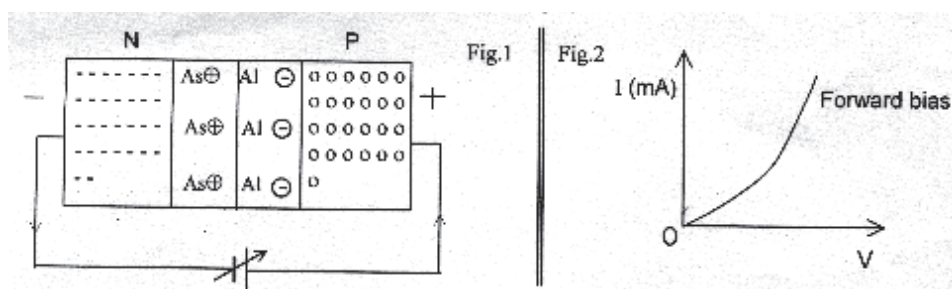

When connected in this way, the potential difference across the depletion layer is in a direction which is opposite to the applied voltage. Therefore, the "height" of the depletion layer potential is reduced, and its width is also simultaneously reduced. Hence the electron can now easily move from N to P side. Therefore, under the influence of the external voltage applied in this sense, the electrons move from the N side to the P-side and finally reach the positive terminal of the battery, to emerge from the negative terminal and continue their circulation. Thus, a current can be established in the circuit easily. If the voltage applied by the battery is increased, the current also increases as shown in figure. Note that the current shown in the external circuit of the figure is the conventional current which is opposite to the direction of the flow of electrons.

(C) 1. Given $\lambda = 6000 \text{ \AA} = 6 \times 10^{-7} \text{ m}$, $\lambda_\gamma = 1.5 \times 10^{-14} \text{ m}$, $n = ?$

Suppose n number of photons of wavelength 6000 \AA have energy equal to the energy of 1 photon of γ -ray then, $E_\gamma = nE$

$$\therefore hf_\gamma = nhf$$

$$\Rightarrow \frac{hc}{\lambda_\gamma} = n \frac{hc}{\lambda} \Rightarrow n = \frac{\lambda}{\lambda_\gamma} = \frac{6 \times 10^{-7}}{1.5 \times 10^{-14}} = 4 \times 10^7$$

2. If halflife = x minutes. Where $x = 15$ minute.

substituting value of λ in equation (1)

3.

4.

Common base current gain

Common emitter current gain
