

**Section-I: General Aptitude**

- $2^{(x-1)} - 2^{(x-4)} = 7(2^{11})$, what is x ?
(A) 9 (B) 11 (C) 13 (D) 15
- Length of a rectangle increases by 20%, while its breadth reduces by 10%. Find the percentage change in its perimeter.
(A) 10% increase (B) 8% increase (C) 5% increase (D) Can't say
- In a group, average weight of the females was 60kgs. The average weight of the entire group was twice as close to the average weight of the men as it was to the average weight of the women. What percentage of the group were women?
(A) 40 (B) 33.33 (C) 50 (D) 66.67
- Govind decided to walk down the escalator of a shopping mall. He found that if he walks down 25 steps, he requires 15 seconds to reach the bottom. However, if he steps down 13 steps, he requires 24 seconds to reach the bottom. Find out the height of the stairway in steps.
(A) 30 (B) 40 (C) 45 (D) 50
- Taps A and B, operating simultaneously, can fill a certain tank in 72 min; Taps A and C, operating simultaneously, can fill the tank in 90 min; and Taps B and C, operating simultaneously, can fill the tank in 2 hours. How many hours does it take Taps A, B, and C, operating simultaneously, to fill the tank ?
(A) $\frac{1}{3}$ (B) 1 (C) $\frac{2}{3}$ (D) $\frac{5}{6}$
- A customer at Paradise hotel calculates his tip by adding a constant amount to another sum that is directly proportional to the total bill for the meal. If the total bill for his meal had been 100/- greater, the customer would've calculated a tip of 60/-. If the total bill for his meal had been 150/- less, the customer would've calculated a tip of 40/-. If his total bill for the meal was 600/- what will be the amount of his tip?
(A) 48 (B) 56 (C) 52 (D) 50
- There are five hotels in a line. If 4 men go into a hotel at 11 am, then what will be the probability that each go into a different hotel?
(A) $\frac{124}{125}$ (B) $\frac{24}{125}$ (C) $\frac{42}{125}$ (D) $\frac{48}{625}$
- In a class of 40 students, 12 enrolled for both English & German. 22 enrolled for German. If students of class enrolled at least one of the subjects, then how many students enrolled for only English & not German?
(A) 30 (B) 12 (C) 18 (D) 40



9. Mr. Vikas buys some apples at 8 per rupee from one trader and a similar quantity at 5 per rupee from another trader. He mixes both the varieties and sell the whole at 9 per rupee. What is the profit or loss percentage that he makes?
(A) 31.62 % Profit (B) 31.62 % Loss (C) 46.25 % Profit (D) 46.25 % Loss

10.

Type of program ↓	AGE Group →	15-20	21-30	31+
Daily Serials		6	4	17
Comedy		7	5	5
Singing/dancing		6	12	14
Devotional		1	4	11
News		2	3	15
Sports		9	3	4
Quiz		2	2	2
Total		33	33	68

- What percentage of respondents aged 21-30 indicated a favourite program other than singing/dancing?
(A) 36 % (B) 46 % (C) 64 % (D) 60 %

11. **Analogy**

AESTHETICS : BEAUTY ::

- (A) ethics: etiquette (B) epistemology : knowledge
(C) theology: morals (D) rhetoric : reasoning
12. Choose the appropriate antonym for the word **ABOMINATE**
(A) loathe (B) despise (C) adore (D) abhor
13. Choose the sentence that is grammatically correct:
(A) The serving bowl or the plates go on that shelf
(B) The serving bowls or the plate go on that shelf
(C) The serving bowl or the plate go on that shelf
(D) The serving bowls or the plates goes on that shelf
14. The management of the company had cordially invited its staff for the 25th Anniversary function.
Choose the best conclusion:
(A) The company is going to wind-up the next year
(B) It is mandatory for all the staff to attend the function
(C) The management of the company is spend-thrift
(D) The company is well-established



15. Find out the error part in the given sentence
Ram is junior / than shyam / and Ram is / older than shyam
(A) (B) (C) (D)
16. Find the proper meaning of the words given in bold letters.
After working for years in the same company, Ramu decided to **Jack it all**.
(A) Continue (B) Change (C) Stop (D) Cheat.
17. Urban services have not expanded fast enough to cope up with urban expansion. Low investment allocations have tended to be underspent. Both public and private infrastructure quality has declined. The impact of the environment in which children live and the supporting services available to them when they fall ill, seem clear. The decline in average food availability and the rise in absolute poverty, point in the same unsatisfactory directions.
Choose the weakest statement related to the above passage
(A) Though adequate provisions of funds were made but they were received under spent
(B) Low cost urban housing is on the priority
(C) There is nothing to boast about urban services
(D) Birth rate is higher in urban areas than in rural areas
18. **Sentence completion**
Data concerning the effects on a small population of high concentrations of a potentially hazardous chemical are frequently used to ----- the effects on a large population of lower amounts of the same chemical.
(A) verify (B) redress (C) predict (D) realize
19. **Select the best alternative for the underlined part:**
Currently 93,250,000 billion barrels a year, world consumption of oil is rising at a rate of 3 percent annually.
(A) world consumption of oil is rising at a rate of
(B) the world is consuming oil at an increasing rate of
(C) the world's oil is being consumed at the increasing rate of
(D) the rise in the rate of the world's oil consumption is
20. False currency is being supplied to India through buses that run between India and Pakistan. Find out the course of action to be taken.
(A) The govt. should ban the buses
(B) The govt. should change the currency
(C) The govt. should strengthen the vigilance
(D) Indian govt. should warn the Pakistan govt.

**Section-II: Technical**

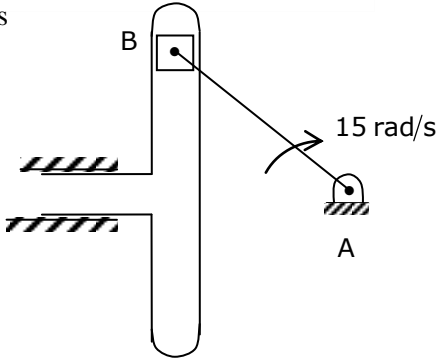
- A heat pump working as a reversed Carnot cycle has a COP of 5. If it is made to work as refrigerator taking 1kW of work input, the refrigerating effect will be
(A) 1kW (B) 2kW (C) 4kW (D) 5kW
- In inventory control system, ABC analysis is based on which of the following principle?
(A) Pareto rule (B) Wilson Harris model
(C) EOQ model (D) None of these
- Two plates are fixed together by means of two rivets. Both rivets and plates are made of plain carbon steel 10C4 with yield strength of 250MPa. The load of 5kN is applied on both ends of the plates and the factor of safety is 2.5. Determine the diameter of rivet according to the principle of shear stress theory.
(A) 8 mm (B) 12 mm (C) 20 mm (D) 4 mm
- A vessel of volume 0.05m^3 contains a mixture of saturated water and saturated steam at a temperature of 250°C . If the mass of liquid present is 8 kg, then the enthalpy of the mixture in kJ/kg will be _____.
(At 250°C , $h_f=1085.36$ kJ/kg, $h_{fg}=1716.2$ kJ/kg, $v_f=0.0012512\text{m}^3/\text{kg}$, $v_g=0.05013\text{m}^3/\text{kg}$)
(A) 1341 (B) 1241 (C) 1427 (D) 7256
- What would be expectation of number of failures preceding the first success in an infinite series of independent trials with constant probability of success p?
(A) $\frac{1}{p}$ (B) $\frac{1}{q}$ (C) $\frac{q}{p}$ (D) None of these
- For the mechanism shown, radius of crank is 50 cm. Point B is at the slides. Vertical velocity of B is 375 cm/s then Coriolis Acceleration of slides is
(A) 56.25 m/s^2
(B) 112.5 m/s^2
(C) 90 m/s^2
(D) Zero

- A vertical rod of diameter 50mm and 1.5m long is fixed at the upper end. It has a collar attached at lower end. A weight of 200N is dropped from a height of 25mm from collar. Assume change in length is comparable with height from which it is dropped. Take $E = 2 \times 10^5\text{N/mm}^2$. The stress induced in the rod due to impact is
(A) 16.22 N/mm^2 (B) 42.67 N/mm^2 (C) 26.16 N/mm^2 (D) 19.19 N/mm^2



8. For an ideal gas

- (A) $\left(\frac{\partial S}{\partial T}\right)_p < \left(\frac{\partial S}{\partial T}\right)_r$ (B) $\left(\frac{\partial T}{\partial S}\right)_p < \left(\frac{\partial T}{\partial S}\right)_r$
 (C) $\left(\frac{\partial T}{\partial S}\right)_p < \left(\frac{\partial T}{\partial S}\right)_v$ (D) $\left(\frac{\partial S}{\partial T}\right)_p = \left(\frac{\partial S}{\partial T}\right)_v$

9. Two helical gears have 20 and 34 teeth with a normal diametral pitch of 8. The left handed pinion has a helix angle of 40° and a rotational speed of 1000 rpm. The gear is also left handed and has a helix angle of 40° . The angular velocity of gear is _____ rpm

- (A) 255 (B) 355 (B) 788 (D) 588

10. Find the strain energy stored in member AB of the pin jointed stress, shown in the figure, when E and A are same for all members.

- (A) $\frac{2P^2L}{2E}$ (B) $\frac{P^2L}{AE}$
 (C) $\frac{P^2L}{2AE}$ (D) Zero

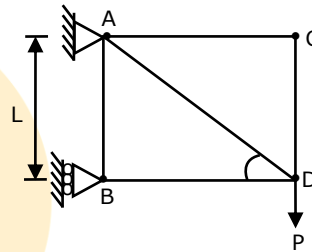

11. Evaluate $\iint xy(x+y)dx dy$ taken over the area between $y = x^2$ and $y = x$.

- (A) 0 (B) 2/56 (C) 1/56 (D) 3/56

12. For one unit of end product – P, 2 A's, 3 B's and 4 C's are required. Each A requires 3 M's and 4 N's. One unit of B requires 4 C's and 5 D's. If 40 P's are needed and on hand there are 50 B's, how many more C's are needed?

- (A) 440 (B) 480 (C) 640 (D) 200

13. A cone floating in water with its apex downwards has a diameter 2m and vertical height 4m. Specific gravity of material of cone is 0.027. Cone is in which equilibrium?

- (A) Stable (B) Unstable (C) Neutral (D) Can't say

14. A hollow stainless steel spherical container having 20cm inside diameter and 30cm outer diameter (with $k = 50W/mK$) holds certain liquid. If its inner and outer surfaces are at $250^\circ C$ and $100^\circ C$, then the radial heat flow (in kW) is _____.

- (A) 38 (B) 28 (C) 48 (D) 18

15. In a gating design, Sprue has an area 6.4 cm^2 , where pouring basin meets the sprue. Sprue length is 25 cm and desired molten metal flow rate is $900 \text{ cm}^3/\text{s}$. The area of sprue at the bottom to avoid air aspiration effect is

- (A) 5 cm^2 (B) 3.43 cm^2 (C) 7.3 cm^2 (D) None of the above



16. The end of a flexible but in extensible rope of length L and mass ρ per unit length which is pulled on the platform is lifted vertically with a constant velocity v by a variable force p . The variable force p is given by

- (A) $p = \rho v^2$ (B) $p = \frac{1}{2} \rho v^2$
 (C) $p = \frac{1}{2} \rho v^2 + \rho g x$ (D) $p = \rho v^2 + \rho g x + \rho g L$

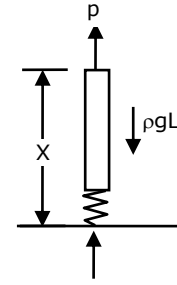

17. The iterative root of $f(x) = 3x^2 + 2x + 1$ using Newton Raphson method is

- (A) $x_{n+1} = \frac{3x_n^2 + 1}{6x_n + 2}$ (B) $x_{n+1} = \frac{9x_n^2 + 4x_n + 1}{6x_n + 2}$
 (C) $x_{n+1} = \frac{3x_n^2 - 1}{6x_n + 2}$ (D) $x_{n+1} = \frac{9x_n^2 - 4x_n - 1}{6x_n + 2}$

18. A shaft has an attached disc at the centre of its length. The disc has its centre of gravity located at a distance of 2mm from the axis of the shaft. When the shaft is allowed to vibrate in its natural bow-shaped mode, it has a frequency of vibration of 10rad/s. When the shaft is rotated at 300 revolutions per minute, it will whirl with a radius of

- (A) 2mm (B) 2.25mm (C) 2.50mm (D) 4.25mm

19. In a sample of moist air at standard atmospheric pressure of 1 bar and 27°C, the partial pressure of water vapour is 2.344 kPa. If the saturation pressure of water vapour is 3.36kPa at 27°C, then what is the humidity ratio and relative humidity of moist air sample?

- (A) 0.9876 and 69.76% (B) 0.01472 and 69.76%
 (C) 0.1472 and 46.35% (D) 0.01344 and 40%

20. A variable force is applied on an object in such a manner that the line of application of the force will always be at a distance of $3/4^{\text{th}}$ of its height from base. The final state of the object is

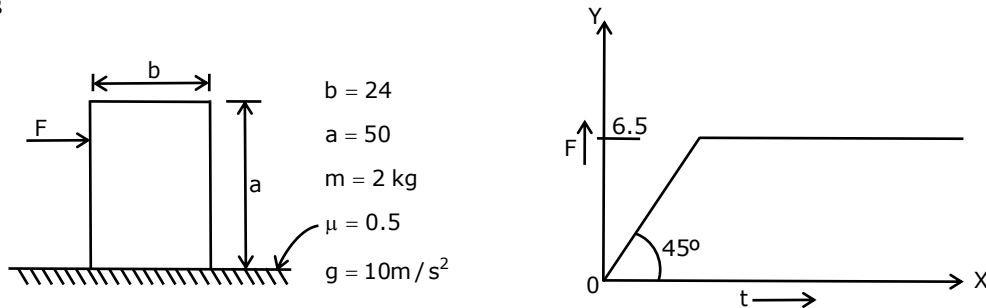

- (A) The object does not move at all as the frictional force will balance applied force.
 (B) The object will move due to the unbalanced frictional force.
 (C) The body will continue toppling.
 (D) The body will first topple and then will come to rest i.e. the object moves no further



21. $\int_0^{\infty} \int_y^{\infty} x e^{-\frac{x^2}{y}} dx dy = \underline{\hspace{2cm}}$.
- (A) 0.5 (B) 1 (C) 1.5 (D) 2
22. Thermal radiation strikes a surface which has a reflectivity of 0.55 and a transmissivity of 0.032. The absorbed flux as measured indirectly by heating effect works out to be 95 W/m^2 then the rate of incident flux is $\underline{\hspace{2cm}} \text{ W/m}^2$
- (A) 227 (B) 287 (C) 327 (D) 387
23. Velocity in a spacecraft's pipe of square cross section is varying with respect to distance of space craft as $\dot{V} = 3S - S^2 \left(\dot{V} \text{ in LPM} \right)$. If the area of cross section is 4 cm^2 , the maximum mass flow rate achievable in pipe of space craft is $\underline{\hspace{2cm}} \text{ gm/min}$.
(Take Specific gravity of fluid as 1.2).
- (A) 1.08 (B) 2.09 (C) 2.86 (D) 3.9
24. A 600 mm diameter milling cutter has 6 teeth and it is used to face mill a work piece 300 mm long and 40 mm wide work piece. If speed (N) is 1000 rpm and feed is 0.1 mm/rev then the machining time is
- (A) 0.326 min (B) 0.426 min (C) 0.502 min (D) 0.626 min
25. General solution of $\frac{xdy}{dx} = 2 - 4x^3$ is
- (A) $y = 2 \ln x - \frac{4x^3}{3} + c$ (B) $y = \ln x - \frac{4x^3}{3} + c$
- (C) $y = 2 \ln x + \frac{4x^3}{3} + c$ (D) $y = x^2 - \frac{4 \ln x^3}{3} + c$

26. A pulley bracket is supported by 4 bolts, 2 at section AA, 2 at section BB, weight of pulley and bracket is 90kg, load 'P' on rope (each) is 2250 kg Centre of gravity shown in figure is of combined bracket and pulley. D is the wall where C.G at 'D' is 37.5 cm and distance between D and O is 4.5 cm. where 'O' is bracket pulley hinge point.

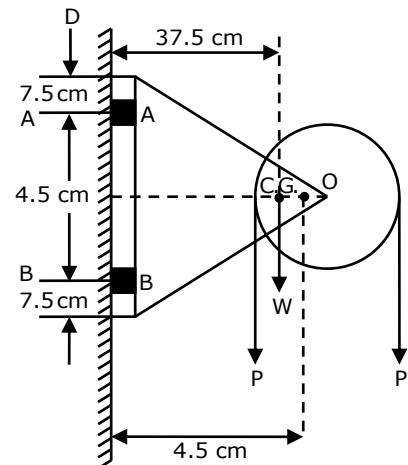

If $d_c = 0.84d$ and shear stress is 350 kgf/cm^2 then what is the bolt diameter?

- (A) 15 mm (B) 28 mm
(C) 5 mm (D) 10 mm



27. A man at A is hoisting a safe 'S' as shown in figure by walking to the right with a constant velocity (V_A) is 0.5m/sec. The rope is 30 m long and passes over a small pulley at D. The velocity of the safe when it reaches the window elevation at E will be

- (A) 0.8m/sec
(B) 0.4m/sec
(C) 1.1m/sec
(D) 1.5m/sec

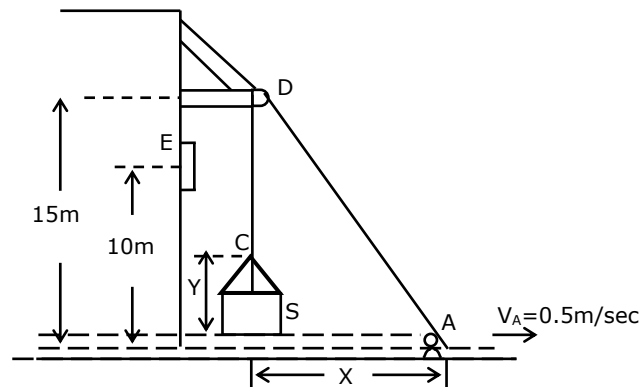

28. A company produces 9000 televisions annually. The set up cost per order is Rs. 9000. Set up and factory cost is Rs. 500 each. Carrying cost on average finished goods is 20% of unit price and production rate is 200 per day. The maximum inventory level will be _____.

- (A) 1050 (B) 1500 (C) 1192 (D) 1300

29. A Kaplan turbine develops 2850 kW under a net head of 5.2m. It is provided with a draft tube with its inlet (diameter 3m) set 1.8m above the tail race level. A vacuum gauge connected to the draft tube indicates a reading of 5.2m of water. Assume draft tube efficiency as 75 percent. What will be the efficiency of the turbine?

- (A) 93.55% (B) 83.82% (C) 73.65% (D) 63.85%

30. Which of the following is the time required for taking a complete cut on plate 610mm x 920mm, if the cutting speed is 10m/min, the return time to cutting time ratio is 1:4, the feed is 3mm and the clearance at each end is 80mm.

- (A) 29.5min (B) 34.5min (C) 39.5min (D) 41min