



Section-I: General Aptitude

- $2^{(x-1)} - 2^{(x-4)} = 7(2^{11})$, what is x?
(A) 9 (B) 11 (C) 13 (D) 15
- Length of a rectangle increases by 20%, while its breadth reduces by 10%. Find the percentage change in its perimeter.
(A) 10% increase (B) 8% increase (C) 5% increase (D) Can't say
- In a group, average weight of the females was 60kgs. The average weight of the entire group was twice as close to the average weight of the men as it was to the average weight of the women. What percentage of the group were women?
(A) 40 (B) 33.33 (C) 50 (D) 66.67
- Govind decided to walk down the escalator of a shopping mall. He found that if he walks down 25 steps, he requires 15 seconds to reach the bottom. However, if he steps down 13 steps, he requires 24 seconds to reach the bottom. Find out the height of the stairway in steps.
(A) 30 (B) 40 (C) 45 (D) 50
- Taps A and B, operating simultaneously, can fill a certain tank in 72 min; Taps A and C, operating simultaneously, can fill the tank in 90 min; and Taps B and C, operating simultaneously, can fill the tank in 2 hours. How many hours does it take Taps A, B, and C, operating simultaneously, to fill the tank?
(A) 1/3 (B) 1 (C) 2/3 (D) 5/6
- A customer at Paradise hotel calculates his tip by adding a constant amount to another sum that is directly proportional to the total bill for the meal. If the total bill for his meal had been 100/- greater, the customer would've calculated a tip of 60/-. If the total bill for his meal had been 150/- less, the customer would've calculated a tip of 40/-. If his total bill for the meal was 600/- what will be the amount of his tip?
(A) 48 (B) 56 (C) 52 (D) 50
- There are five hotels in a line. If 4 men go into a hotel at 11 am, then what will be the probability that each go into a different hotel?
(A) $\frac{124}{125}$ (B) $\frac{24}{125}$ (C) $\frac{42}{125}$ (D) $\frac{48}{625}$
- In a class of 40 students, 12 enrolled for both English & German. 22 enrolled for German. If students of class enrolled at least one of the subjects, then how many students enrolled for only English & not German?
(A) 30 (B) 12 (C) 18 (D) 40



9. Mr. Vikas buys some apples at 8 per rupee from one trader and a similar quantity at 5 per rupee from another trader. He mixes both the varieties and sell the whole at 9 per rupee. What is the profit or loss percentage that he makes?
(A) 31.62 % Profit (B) 31.62 % Loss (C) 46.25 % Profit (D) 46.25 % Loss

10.

Type of program ↓	AGE Group →	15-20	21-30	31+
Daily Serials		6	4	17
Comedy		7	5	5
Singing/dancing		6	12	14
Devotional		1	4	11
News		2	3	15
Sports		9	3	4
Quiz		2	2	2
Total		33	33	68

What percentage of respondents aged 21-30 indicated a favourite program other than singing/dancing?

- (A) 36 % (B) 46 % (C) 64 % (D) 60 %
11. **Analogy**
AESTHETICS : BEAUTY ::
(A) ethics: etiquette (B) epistemology : knowledge
(C) theology: morals (D) rhetoric : reasoning
12. Choose the appropriate antonym for the word **ABOMINATE**
(A) loathe (B) despise (C) adore (D) abhor
13. Choose the sentence that is grammatically correct:
(A) The serving bowl or the plates go on that shelf
(B) The serving bowls or the plate go on that shelf
(C) The serving bowl or the plate go on that shelf
(D) The serving bowls or the plates goes on that shelf
14. The management of the company had cordially invited its staff for the 25th Anniversary function.
Choose the best conclusion:
(A) The company is going to wind-up the next year
(B) It is mandatory for all the staff to attend the function
(C) The management of the company is spend-thrift
(D) The company is well-established



15. Find out the error part in the given sentence
Ram is junior / than shyam / and Ram is / older than shyam
(A) (B) (C) (D)
16. Find the proper meaning of the words given in bold letters.
After working for years in the same company, Ramu decided to **Jack it all**.
(A) Continue (B) Change (C) Stop (D) Cheat.
17. Urban services have not expanded fast enough to cope up with urban expansion. Low investment allocations have tended to be underspent. Both public and private infrastructure quality has declined. The impact of the environment in which children live and the supporting services available to them when they fall ill, seem clear. The decline in average food availability and the rise in absolute poverty, point in the same unsatisfactory directions.
Choose the weakest statement related to the above passage
(A) Though adequate provisions of funds were made but they were received under spent
(B) Low cost urban housing is on the priority
(C) There is nothing to boast about urban services
(D) Birth rate is higher in urban areas than in rural areas
18. **Sentence completion**
Data concerning the effects on a small population of high concentrations of a potentially hazardous chemical are frequently used to ----- the effects on a large population of lower amounts of the same chemical.
(A) verify (B) redress (C) predict (D) realize
19. **Select the best alternative for the underlined part:**
Currently 93,250,000 billion barrels a year, world consumption of oil is rising at a rate of 3 percent annually.
(A) world consumption of oil is rising at a rate of
(B) the world is consuming oil at an increasing rate of
(C) the world's oil is being consumed at the increasing rate of
(D) the rise in the rate of the world's oil consumption is
20. False currency is being supplied to India through buses that run between India and Pakistan. Find out the course of action to be taken.
(A) The govt. should ban the buses
(B) The govt. should change the currency
(C) The govt. should strengthen the vigilance
(D) Indian govt. should warn the Pakistan govt.



Section-II: Technical

- What would be expectation of number of failures preceding the first success in an infinite series of independent trials with constant probability of success p ?
 (A) $\frac{1}{p}$ (B) $\frac{1}{q}$ (C) $\frac{q}{p}$ (D) None of these
- A steel cantilever of length 0.25 m, width 10 mm and thickness 2 mm is used to measure displacement x , as shown in figure. Sensitivity of LVDT is 2V/mm and maximum output voltage of LVDT is 12V.

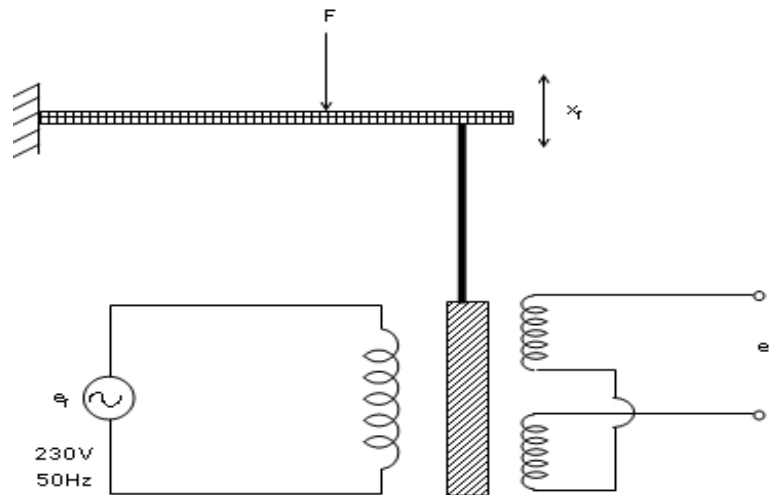

The maximum force 'F' that can be applied on this setup is _____ (in Newtons).

(Young's modulus of steel is 180 GN/m^2)

- (A) 1.383 (B) 2.835 (C) 5.283 (D) 4.872
- The figure shown is an electronic proportional controller. To have the proportional band of 25%, the value of R_1 should be

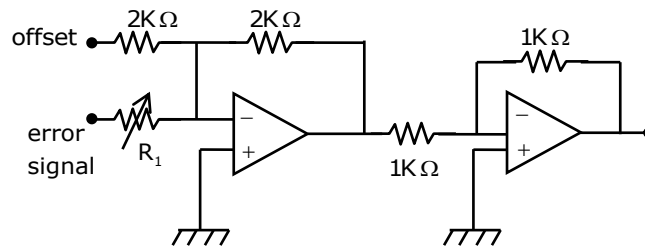

- (A) 500Ω (B) 1000Ω (C) 1500Ω (D) 2500Ω
- The polar plot of a system with transfer function $G(s) = \frac{k}{s(s+T)}$ for positive T and negative k will lie in
 (A) First quadrant (B) Second quadrant
 (C) Third quadrant (D) Fourth quadrant



5. Evaluate $\iint xy(x+y)dx dy$ taken over the area between $y = x^2$ and $y = x$.
 (A) 0 (B) 2/56 (C) 1/56 (D) 3/56

6. For the given circuit $C = 2F$, $R = 2\Omega$

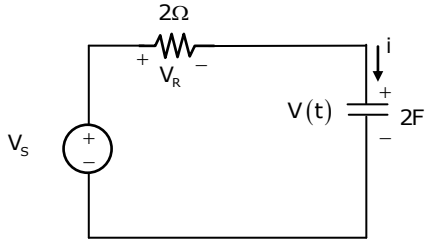

The voltage function is shown below
 The current $i(t)$ for $0 < t \leq 1$ is

- (A) 1.6 A
 (B) 3.5 A
 (C) 4.5 A
 (D) 2.5 A

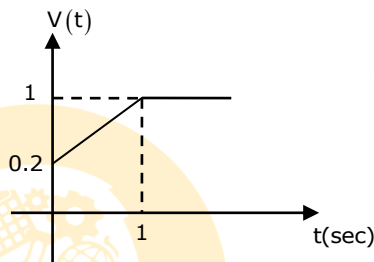

7. In a cylindrical piston, cylinder and piston are of same length. If capacitance measured at output when piston moves entirely into cylinder is 137 pF, then length of piston is ($\epsilon_{\text{medium}} = 8.85 \times 10^{-12} \text{ F/m}$)

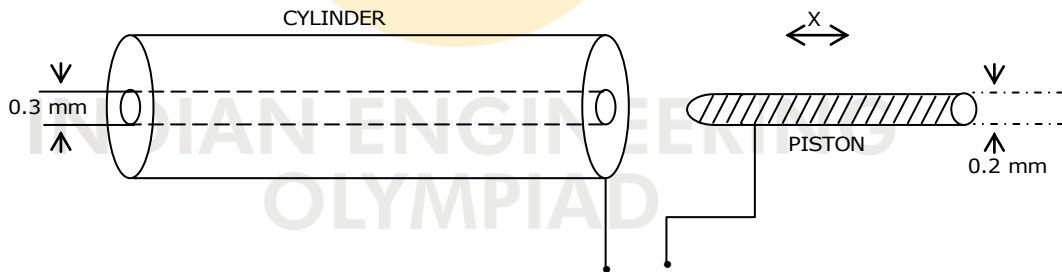

- (A) 55.5 meter (B) 8.85 meter (C) 1 meter (D) None

8. The state equation of a system is given below, the system is

$$\dot{x}_1 = x_1 + x_2 + U; \quad \dot{x}_2 = x_1 \quad \text{and} \quad y = x_2$$

- (A) Controllable and not observable
 (B) Observable and not controllable
 (C) Not controllable and not observable
 (D) Controllable and observable

9. For the circuit shown below, the value of I_L must be

- (A) 1 A
 (B) -1 A
 (C) -1.33 A
 (D) 2 A

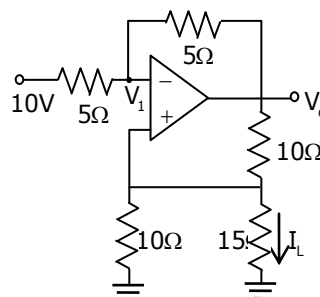



10. Find the signal $x[n]$ whose DTFT is $X_p(\Omega) = \frac{2e^{-j\Omega}}{1-0.25e^{-j2\Omega}}$.
- (A) $2(0.5)^n u[n] + 2(-0.5)^n u[n]$ (B) $2(0.5)^n u[n] - 2(-0.5)^n u[n]$
 (C) $2(0.5)^n u[n] - 2(0.5)^n u[-n]$ (D) $2(0.5)^n u[n] - 2(-0.5)^n u[-n]$

11. Consider the interfacing circuit shown below

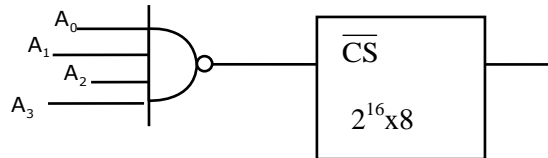

The memory map is given by

- (A) $000F - FFFF_H$ (B) $010F_H - FFFF_H$ (C) $001F_H - FFFF_H$ (D) $001F_H - EFFF_H$
12. The iterative root of $f(x) = 3x^2 + 2x + 1$ using Newton Raphson method is
- (A) $x_{n+1} = \frac{3x_n^2 + 1}{6x_n + 2}$ (B) $x_{n+1} = \frac{9x_n^2 + 4x_n + 1}{6x_n + 2}$
 (C) $x_{n+1} = \frac{3x_n^2 - 1}{6x_n + 2}$ (D) $x_{n+1} = \frac{9x_n^2 - 4x_n - 1}{6x_n + 2}$

13. The Thevenin's resistance between the terminals A and B is

- (A) 40.57Ω
 (B) 58.82Ω
 (C) 51Ω
 (D) 46.13Ω

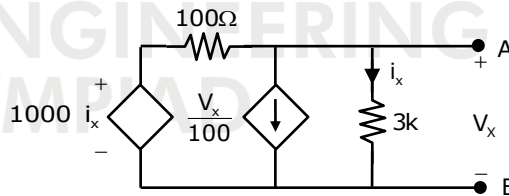

14. A spring-mass system based accelerometer is used to measure the acceleration of a vehicle. If initial spring position at P1 changes to P2 which is at a distance of 5 cm from P1, then (Spring constant = 2kN/m , seismic mass = 0.025 kg)
 Acceleration of vehicle is _____ m/s^2 .

- (A) 4000
 (B) 5000
 (C) 6000
 (D) 7000

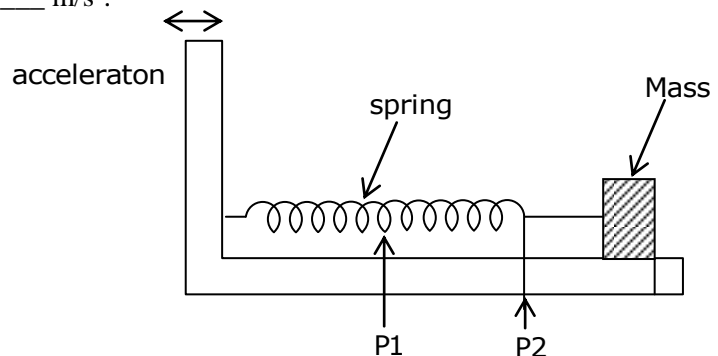



15. A binary PAM communication system employs rectangular pulses of duration T_b and amplitudes $\pm A$ to transmit digital information at a rate $R=10^5$ bits/sec. If the power-spectral density of the additive Gaussian noise is $\frac{N_0}{2}$, where $N_0 = 10^{-2} \text{ W/Hz}$, then the value of A that is required to achieve a probability of error $P_2 = 10^{-6}$ is
($Q(X) = 10^{-6}$ iff $X = 4.75$)
(A) 106 (B) 55 (C) 205 (D) 306

16. $\int_0^\infty \int_y^\infty x e^{-\frac{x^2}{y}} dx dy = \underline{\hspace{2cm}}$.
(A) 0.5 (B) 1 (C) 1.5 (D) 2

17. Suppose $X[k]$ is the 6-point discrete Fourier transform (DFT) of $x[n] = \{4, 3, 2, 1, 0, 0\}$, and $Y[k] = W_6^{4k} X[k]$, where $Y[k]$ is the 6-point DFT of $y[n]$ and $W_6 = e^{-j\frac{2\pi}{6}}$. Which one of the following represents $y[n]$?
(A) $y[n] = \left\{ \begin{matrix} 0, 3, 2, 1, 0, 4, 0 \\ \uparrow \end{matrix} \right\}$ (B) $y[n] = \left\{ \begin{matrix} 2, 1, 0, 0, 4, 3 \\ \uparrow \end{matrix} \right\}$
(C) $y[n] = \left\{ \begin{matrix} 0, 0, 4, 3, 2, 1 \\ \uparrow \end{matrix} \right\}$ (D) $y[n] = \left\{ \begin{matrix} 3, 2, 1, 0, 0, 4 \\ \uparrow \end{matrix} \right\}$

18. For the diagram shown below, the frequency of output is 10Hz. The input frequency must be

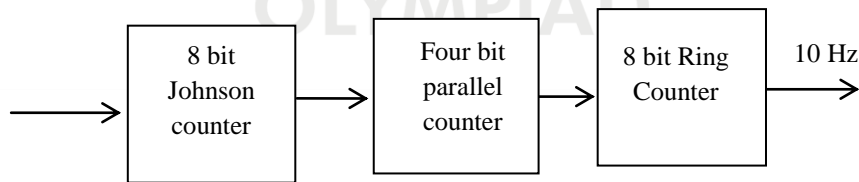

- (A) 20480 Hz (B) 3500 Hz (C) 45000 Hz (D) 15000 Hz
19. For a RLC circuit at series resonance, which of the following are correct?
S1: For the frequencies beyond resonant frequency, as frequency increases the series RLC circuit will start behaving like RC capacitive circuit.
S2: At resonance the voltage across capacitor will be $\frac{V_s}{Q_o}$ (where V_s =source voltage, Q_o =quality factor)
(A) S1 only (B) S2 only (C) Both S1 & S2 (D) None of these



20. General solution of $\frac{xdy}{dx} = 2 - 4x^3$ is
- (A) $y = 2\ln x - \frac{4x^3}{3} + c$ (B) $y = \ln x - \frac{4x^3}{3} + c$
- (C) $y = 2\ln x + \frac{4x^3}{3} + c$ (D) $y = x^2 - \frac{4\ln x^3}{3} + c$
21. Assertion (A) : The relative stability of the system is improved by addition of the zero to the loop transfer function
- Reasoning (R) : Adding left half plane zeros to function $G(s)H(s)$ generally moves and bends root locus to left half of s-plane
- (A) A is false but R is true
(B) A is true but R is false
(C) Both A & R are true and R is correct explanation for A
(D) Both A & R are true and R is not correct explanation of A
22. A fiber with a cladding radius of $100\mu\text{m}$ is bent along a curve of radius "x" cm. To observe the strain of 0.25% in optical cable, the value of 'x' will be
- (A) 3.99 (B) 13.23 (C) 0.3 (D) 16
23. An oscilloscope having $5 \times 5 \text{ cm}^2$ has its own sweep output fed to its input. If x and y plates having same sensitivities then oscilloscope will display a _____.
- (A) sweep wave (B) Circle (C) diagonal line (D) Triangular
24. A Schmitt trigger circuit is shown below. The upper and lower threshold voltages are respectively

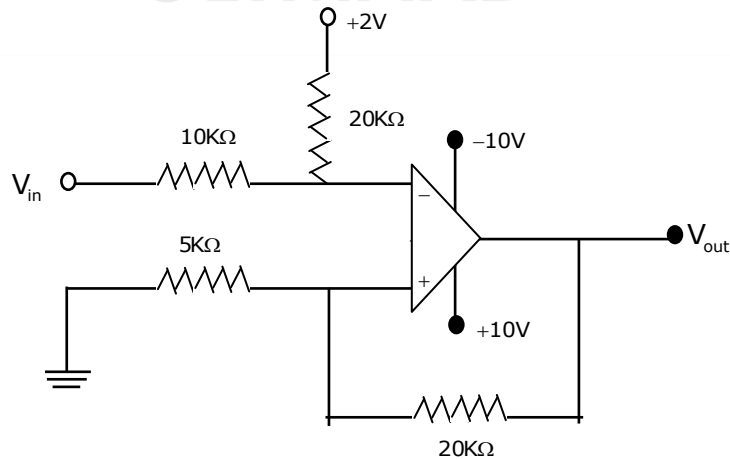

- (A) 2V, -4V (B) 2V, -2V (C) 4V, -4V (D) 4V, -2V



25. The T-type master-slave JK flip-flop is shown along with the clock and input waveforms. The output of the flip flops was zero initially. Identify the correct waveform of Q_1 .

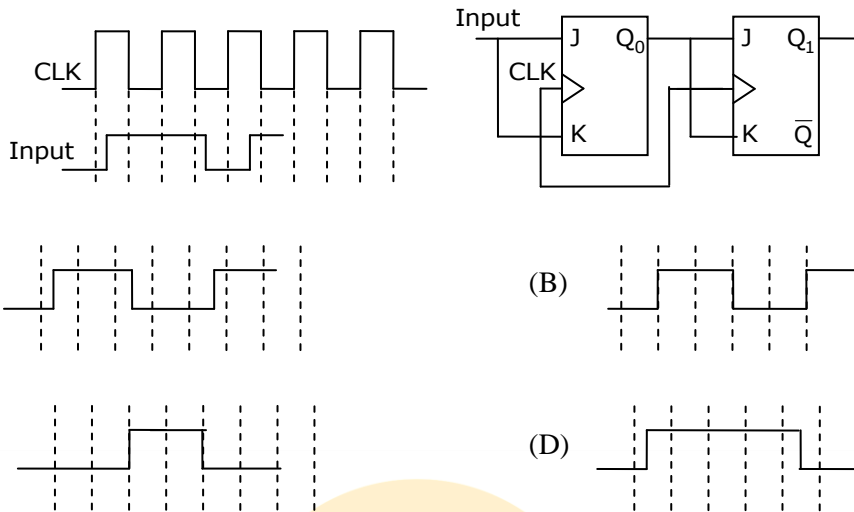

- (A)
- (B)
- (C)
- (D)

26. The T-parameters of circuit shown below are

- (A) $\begin{bmatrix} 2.11 & -3.846 \\ -0.35 & 2.11 \end{bmatrix}$
- (B) $\begin{bmatrix} 1 & 2.11 \\ 3.846 & 0.35 \end{bmatrix}$
- (C) $\begin{bmatrix} 2.11 & 3.846 \\ 0.35 & 1 \end{bmatrix}$
- (D) $\begin{bmatrix} 0.35 & 1 \\ 2.11 & 3.846 \end{bmatrix}$

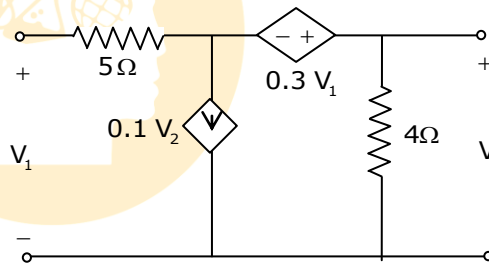

27. For the frequency modulated signal $v(t) = \cos \left[2\pi f_c t + k \int_{-\infty}^t m(\tau) d\tau \right]$, if $m(t)$ has a probability

density function $f_M(m) = \frac{1}{2\sqrt{2\pi}} e^{-\frac{m^2}{8}}$, the r.m.s frequency deviation is

- (A) k (B) $2k$ (C) $\frac{k}{2\pi}$ (D) $\frac{k}{\pi}$

28. Find the expression for the galvanometer current for the circuit shown above.

- (A) $I_g = \frac{E \left[\frac{R_1}{R_1 + R_3} - \frac{R_2}{R_2 + R_4} \right]}{R_g}$
- (B) $I_g = \frac{E \left[\frac{R_3}{R_1 + R_3} - \frac{R_4}{R_2 + R_4} \right]}{\frac{R_1 R_3}{R_1 + R_3} + \frac{R_2 R_4}{R_2 + R_4} + R_g}$
- (C) $I_g = \text{zero}$
- (D) None of these

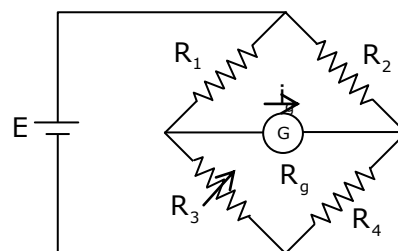



29. Both the transistors have $\beta_0 = 125$, $V_t = 25\text{mV}$ and operated at $I_C = 1\text{mA}$. The overall voltage gain A_V is

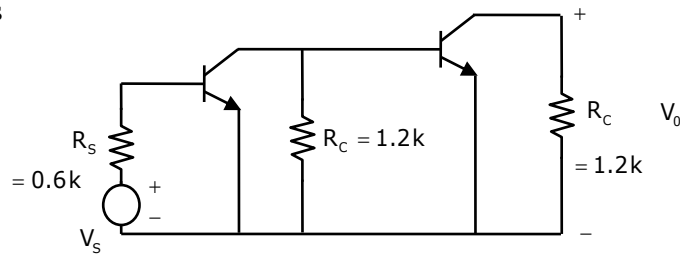

- (A) 1400 (B) 1000 (C) 1650 (D) 1100
30. The characteristic polynomial of a control system is $s^5 - s^4 - s^3 - 17s^2 - 90s - 72$
The number of poles on LHS of imaginary axis is
(A) 2 (B) 3 (C) 4 (D) 5

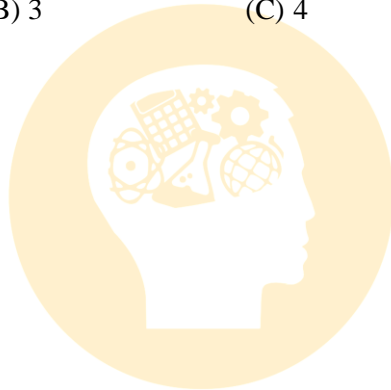

INDIAN ENGINEERING
OLYMPIAD