

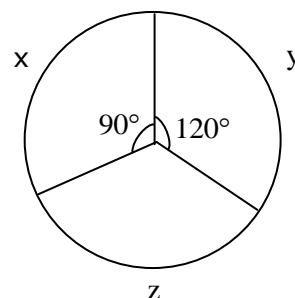

**Section-I: General Aptitude**

1. The values of  $x$  which satisfy  $(x - 1)(x)(x + 1) \leq 0$  is / are  
i.  $x \leq 0$ ;                      ii.  $x \leq -1$                       iii.  $0 \leq x \leq 1$   
(A) Only I                      (B) Both ii and iii                      (C) Both i and ii                      (D) Both i and iii
2. A company awarded annual bonuses to its employees. Of the employees at the company, 70% received bonuses of at least 10,000, 40% received bonuses of at least 50,000, and 20% received bonuses of at least 1,00,000. If 60 employees received bonuses of less than 10,000, how many employees received bonuses of at least 50,000 but less than 1,00,000?  
(A) 80                      (B) 50                      (C) 48                      (D) 40
3. A sum of money compounded annually amounts to thrice itself in 10 years. In how many years, will it become 9 times itself?  
(A) 6                      (B) 8                      (C) 10                      (D) 12
4. Babita was asked to calculate the arithmetic mean of ten positive two digit integers. By mistake, she interchanged the two digits, say  $t$  and  $u$ , in one of these ten integers. As a result, her answer for the arithmetic mean was 1.8 more than what it should have been. Then  $u - t$  equals  
(A) 1                      (B) 2                      (C) 3                      (D) 4
5. Operating alone, Tap A takes twice as long as Tap B takes to fill an empty tank. Operating together at their respective constant rates, the taps can fill the tank in 6 hours. How many hours would it take the Tap A to fill the tank operating alone?  
(A) 18                      (B) 9                      (C) 12                      (D) 15
6. A shopkeeper sells two items at the price of Rs.160. If one of them is sold at 10% profit and another sold at 10% loss, then find the profit/loss?  
(A) 3.23                      (B) 5.75                      (C) 2.5                      (D) 6.9
7. The sum of ages of 5 children born at interval of 3 years each is 50 years. What is the age of youngest child?  
(A) 10                      (B) 2                      (C) 7                      (D) 4
8. The cost of the components  $x$ ,  $y$ ,  $z$  of a machine worth Rs.45,000 in 1996 is given as a pie chart ? In the following year, the cost of the components  $x$ ,  $y$ ,  $z$  increased by 10%, 30%, and 20% respectively. What is the cost of the machine in 1997?

- (A) 54375  
(B) 52375  
(C) 54475  
(D) 54365





9. What is the 2777<sup>th</sup> digit in the sequence 1 2 3 4 5 6 7 8 9 10 11 12 13 14.....?  
(A) 9 (B) 3 (C) 7 (D) 6

10. Production of sugar (in thousand tons) by three sugar mills over the year

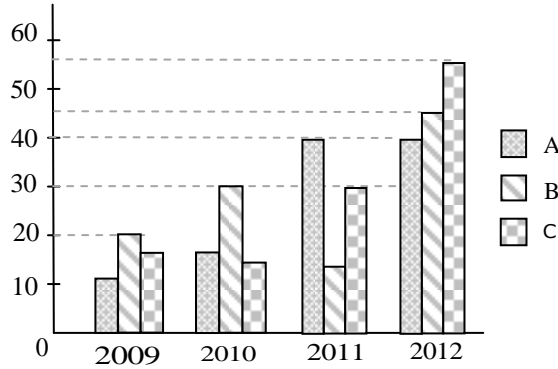

Which of the statement is true ?

- i. Ratio between the production of B in 2011 to C in 2012 is 3 :11  
ii. Average production of A in four years is 20  
iii. Percentage increase in C in 2011 from the previous year is 100%
- (A) i & ii only (B) ii & iii only  
(C) i & iii only (D) i, ii & iii
11. “Students who hired a hack to write their projects were punished”  
Choose the best assumption for the given statement:  
(A) Students have become mischievous  
(B) Hack’s are intelligent  
(C) Hiring a hack is inexpensive  
(D) Students have projects to be done
12. Find out the error part in the given sentence  
Rajesh is/ smarter enough/ to get selected for his post/ without any recommendations  
(A) (B) (C) (D)
13. Arrange the given parts of the sentence in correct order:  
and recognize / all of us must / the machine tool industry / in the Country/  
[1] [2] [3] [4]  
strategic and vital / have a deep introspection / the fact that /  
[5] [6] [7]  
has a very special place / from the point / interests of the nation.  
[8] [9] [10]  
(A) 2,4,7,8,6,9,1,10,3,5 (B) 2,6,5,8,4,3,1,7,10,9  
(C) 2,3,8,9,6,7,10,4,1,5 (D) 2,6,1,7,3,8,4,9,5,10



14. Choose the appropriate word which gives the meaning of the sentence given:  
A critical situation in which no progress can be made:  
(A) Hullabaloo (B) Aggression (C) Histrionic (D) impasse
15. There was once a newspaper vendor who had a rude customer. Every morning the customer throws the money at the vendor. The vendor would pick up the money, smile politely and say, "Thank you sir". The vendor's assistant asked him "why are you always polite with him when he is so rude to you". The vendor replied "He can't help being rude and I can't help being polite".  
What is vendor's conclusion?  
(A) Strive for excellence (B) Work is worship  
(C) Rebels do not realize (D) Keep faith in our own ideas
16. In 1991, produce growers began using a new, inexpensive pesticide, provoking many objections that they would damage both the environment and the produce they were growing. However, the fears have proven unfounded as, though 1996, produce prices had dropped and no ill effects had been reported.  
Which of the following, if true, would be the strongest objection to the argument above?  
(A) Consumption of the produce declined from 1991 to 1993, but rose sharply from 1994 to 1996.  
(B) Several areas in which use of the pesticide was forbidden have also experienced a drop in produce prices.  
(C) The amount of produce grown in 1991 was larger than that of 1996.  
(D) The time since the beginning of the use of the pesticide has been too short to allow some of the predicted effects to occur.
17. Choose the appropriate antonym for the bold word **Linger**  
(A) Sojourn (B) Fiery (C) Condone (D) Quilt
18. Find the proper meaning of the word given in bold letters  
APP won the election **fair and square**.  
(A) Honestly (B) Falsely (C) Corruptedly (D) Unexpectedly
19. None but the rich can afford air travel. Some of those who travel by air become sick. Some of those who become sick require treatment.  
Choose the best conclusion:  
(A) All the rich travel by air  
(B) All the persons who travel by air become sick  
(C) All sick persons travel by air  
(D) Only rich can travel by air
20. **Sentence completion**  
According to Maslow's theory of need hierarchy, material is the \_\_\_\_\_ demand of human beings, in that it provides the founding floor from which the other demands are generated.  
(A) essential (B) basic (C) final (D) emotional



**Section-II: Technical**

1. A bag contains 3 green and 2 red balls. A man draws 2 balls at random from the bag. If he is to receive 20paise for every green ball he draws and 10paise for every red one, what is his expectation (in paisa)?  
 (A) 32 (B) 42 (C) 52 (D) 65

2. The contents of a four-bit register are initially 1011. The register is shifted six times to the right the serial input being 101111.

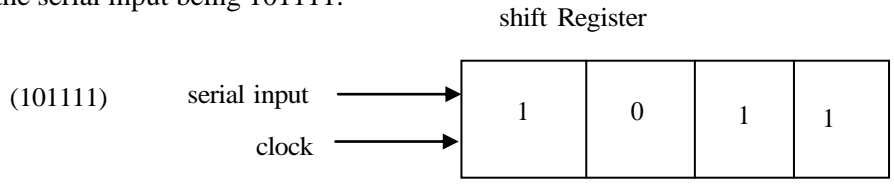

What are the contents of the register after six clock pulses?

- (A) 1110 (B) 0111 (C) 1111 (D) 1011
3. Find out the maximum sine wave output voltage at 2MHz frequency, if the op-Amp slew rate is  $10 \text{ V} / \mu\text{s}$ .  
 (A) 0.8V (B)  $\frac{2}{\pi} \text{ V}$  (C)  $\frac{10}{2\pi} \text{ V}$  (D) 0.4V

4. In the following circuit, the output f is

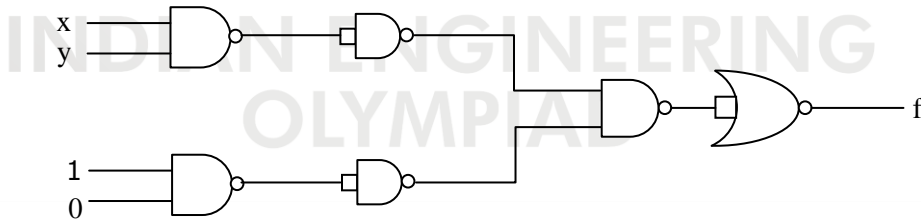

- (A) xy (B) 0 (C) 1 (D) None of these
5. If  $f = x^n + y^n + z^n$ , then  $\nabla f \cdot r =$   
 (A) nf (B) f (C) n (D) 0
  6. Adding a degeneration resistor  $R_E$  to a common emitter BJT amplifier will mainly reduce  
 (A) Voltage gain (B) Input impedance  
 (C) Amplifier bandwidth (D) Output impedance
  7. If the above decoder is used only to display the numbers from 0 to 7 (consider x, y, z as input variables) then what is the simplified Boolean expression (minimal sop) for the output line 'a'?  
 (A)  $y+xz+x'z'$  (B)  $y+x'z+xz'$  (C)  $x+yz+y'z'$  (D)  $x+y'z+yz'$



8. The angular displacement of a semicircular vane of a turbine is measured using capacitance based transducer as shown in figure. Distance between fixed vane and movable vane is 0.1 m, radius of vane is 0.5 m, permittivity of air between vanes =  $8.85 \times 10^{-12}$  F/m. The sensitivity of transducer at  $\theta = 45^\circ$  is

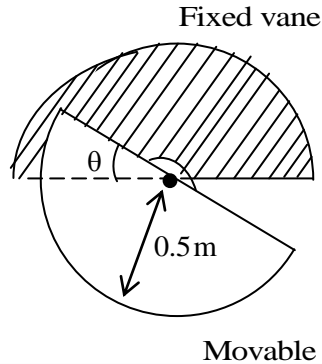

- (A) same as that at  $\theta = 30^\circ$  (B) same as that at  $\theta = 60^\circ$   
 (C) same as that at  $\theta = 135^\circ$  (D) Independent of  $\theta$

9. The slope in Ampere/Volt of the  $I_D$ - $V_{DS}$  load-line for the circuit shown below is

- (A)  $\frac{-1}{400}$   
 (B)  $\frac{-1}{1600}$   
 (C)  $\frac{-1}{2000}$   
 (D)  $\frac{-1}{31000}$

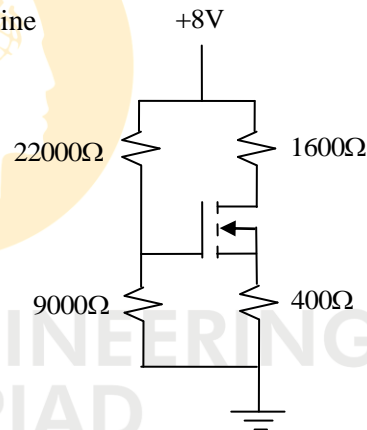

10. A piezoelectric crystal is used as a measuring device which is connected to an amplifier of input impedance  $100\text{k}\Omega$  and capacitance of amplifier is  $100\text{pF}$ , using a  $100\text{m}$  cable of capacitance  $300\text{ pF/m}$ . Phase shift at  $100\text{ Hz}$  is \_\_\_\_\_?

(Leakage resistance of transducer is  $10\text{ M}\Omega$ , capacitance of transducer is  $1000\text{pF}$ )

- (A)  $6.4^\circ$  (B)  $1.82^\circ$  (C)  $0.29^\circ$  (D) None

11. For the configuration shown below, to keep output voltage constant, the load resistance must be

- (A)  $R < 400\Omega$   
 (B)  $600\Omega < R < 2400\Omega$   
 (C)  $400\Omega < R < 2000\Omega$   
 (D)  $500\Omega < R < 2200\Omega$

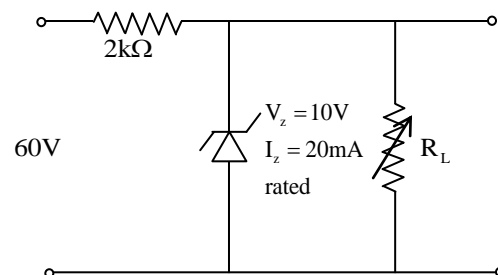



12.  $\lim_{x \rightarrow \infty} \left[ \frac{x^2 + 5x + 3}{x^2 + x + 2} \right]^x =$

- (A)  $e^4$                       (B)  $e^3$                       (C)  $e^2$                       (D)  $e$

13. A non-linear helipot of  $1k\Omega$  total resistance is designed to measure angular displacement of  $0^\circ$  to  $90^\circ$  at temperature of  $50^\circ C$ . The output voltage is  $e_o = 5R_p \sin \theta mV$ . If it is to be used at temperature of  $90^\circ C$  then the maximum output voltage will be \_\_\_\_\_ (in Volts).

Here, derating factor of POT is  $1\Omega / ^\circ C$  and Excitation voltage is 5 volts.

- (A) 4.8                      (B) 5.8                      (C) 6.8                      (D) 2.8

14. Find the voltages  $V_1$  and  $V_2$  for the circuit shown below.

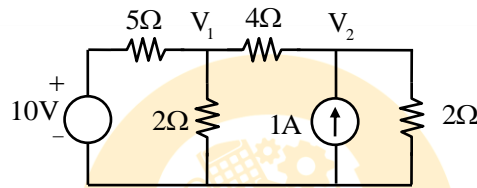

- (A) 0.6 V, 2.75 V      (B) 2.7 V, 2.23 V      (C) 5 V, 4 V                      (D) 0.2 V, 0.8 V

15. The steady state current response of a series R-L-C circuit to sinusoidal input of  $10\sin(\omega t)V$  is given by  $5\sin(\omega t - 30^\circ)A$ . Its current response to an input of  $10\cos(\omega t + 30^\circ)V$  will be

- (A)  $5\cos(\omega t + 30^\circ)A$                       (B)  $5\sin(\omega t)A$   
(C)  $5\sin(\omega t + 30^\circ)A$                       (D)  $5\cos(\omega t)A$

16.  $\oint_C (xy + y^2) dx + x^2 dy =$  \_\_\_\_\_ where C is the closed curve of the region bounded by  $y=x$  and  $y=x^2$

- (A)  $1/20$                       (B)  $-1/20$                       (C)  $1/40$                       (D)  $-1/40$

17. The speed of a shaft is measured by a stroboscope in which single images were observed at 2000rpm, 3000rpm, 4000 rpm, and 5000 rpm. The speed of shaft is

- (A) 1000 rps                      (B) 1000 rpm                      (C) 10000 rps                      (D) 10000 rpm

18. Here as you can see the measured length ends before the mark of 231 cm. What can we say about the measured length with absolute confidence?

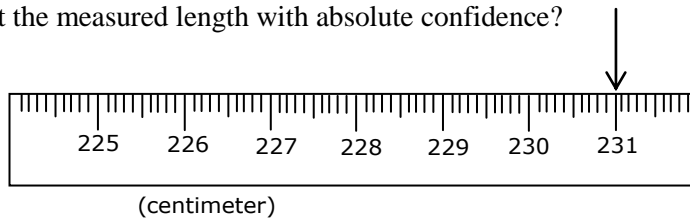

- (A)  $231cm \pm 0.1cm$                       (B)  $230.9cm \pm 0.1cm$   
(C)  $230cm \pm 0.2cm$                       (D)  $231.1cm \pm 0.1cm$



19. A piezoelectric accelerometer with crystal capacitance of 100 pF is used to measure acceleration of a vehicle. Seismic mass=0.01 kg, charge sensitivity of crystal =2 pC/N. The output voltage of the accelerometer for acceleration of 20 m/s<sup>2</sup> is \_\_\_\_\_ mV.  
(A) 4 (B) 5 (C) 10 (D) 12
20. The solution for contour integral  $\oint_{|z|=1} e^{1/z} \sin \frac{1}{z} dz$  is  
(A) 2πi (B) πi (C) 0 (D) 5πi
21. Power in a 1-φ circuit is measured using an electrodynamic wattmeter. The resistance and inductance of wattmeter voltage circuit are 2500Ω and 20mH. At a frequency of 50 Hz and at a power factor of 0.3, the load voltage and load current are 120V and 10A respectively. The current coil has negligible inductance and a minimal resistance of 0.2Ω. What will be the % error in wattmeter reading when pressure coil is connected on the load side?  
(A) 0.797% (B) 2.397% (C) 0.790% (D) 2.341%
22. A capacitor based displacement transducer is designed as shown in figure. Movable electrode is in the middle of two fixed electrodes. The sensitivity of transducer is 10V/m.

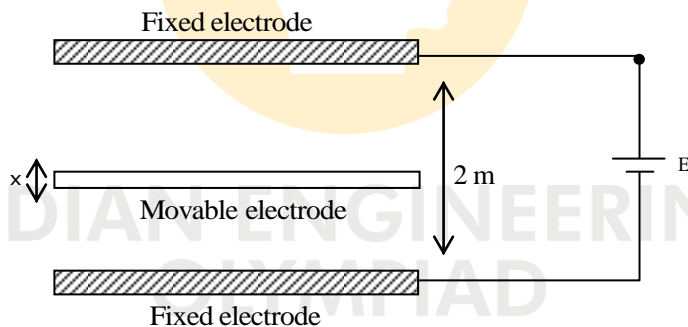

- The differential voltage when movable electrode moves to 0.1 m is \_\_\_\_\_ (in Volts).  
(A) 1 (B) 2 (C) 3 (D) 4
23. An Ayrton shunt is designed to give the ammeter a current range of 1A,5A and 10A. If the internal resistance of PMMC is 50Ω and full scale deflection current is 1mA. Find the values of the resistances in milli ohms?  
(A) 5,5,39.9 (B) 6,6,49.9  
(C) 9.5,8.5,50 (D) 10.5,15,65.5
24. Calculate the effective inductance of the following circuit.

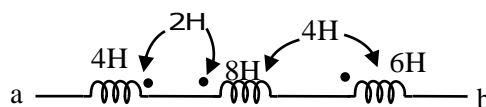

- (A) 24H (B) 22H (C) 18H (D) 10H



25. The circuit shown in the following figure is a

- (A) LPF
- (B) HPF
- (C) BPF
- (D) APF

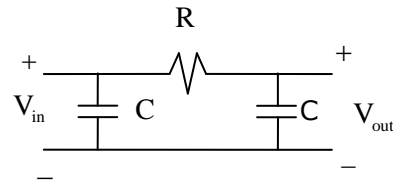

26. Assume simplified h-parameter model for the transistor circuit shown below.

$h_{fe} = 100, h_{ie} = 900\Omega ; R_s = 0.$

The small signal voltage gain  $\frac{V_o}{V_i}$  is given by

- (A) -22
- (B) -20
- (C) 20
- (D) 22

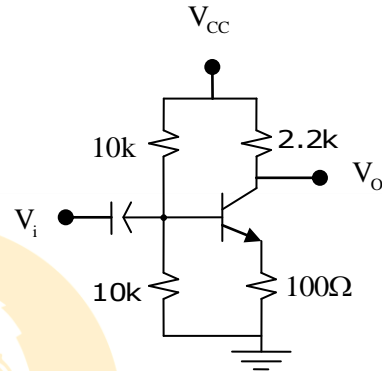

27. A network diagram for a K – G flip flop is shown below.

The next state equation is

- (A)  $Q(t+1) = KG + KQ'$
- (B)  $Q(t+1) = KG + K'Q$
- (C)  $Q(t+1) = K'G + KQ'$
- (D)  $Q(t+1) = (G'+Q')k$

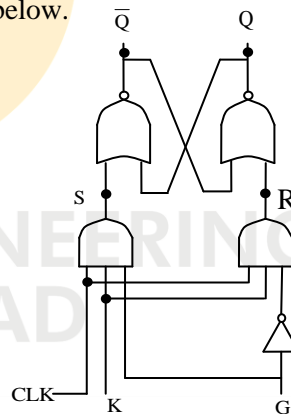

28. In the bridge shown here, the bridge elements are:

$R_1 = 4.5K\Omega; C_1 = 1\mu F$   
 $R_3 = 650\Omega R_2 = 6.5K\Omega$

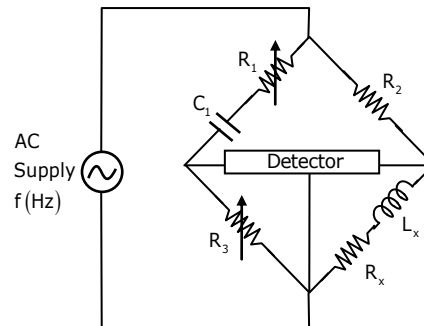

When the bridge is at balance condition for an supply angular frequency of 1000 rad/sec,

The unknown resistance (in ohms) is

- (A) 894
- (B) 452
- (C) 529
- (D) 650





29. In the circuit shown below, find the current  $i(t)$  for  $t \geq 0$  when the switch is opened at  $t = 0$

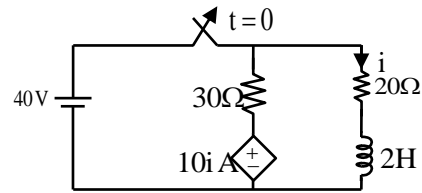

- (A)  $5e^{20t}$  A      (B)  $2e^{-40t}$  A      (C)  $5e^{-10t}$  A      (D)  $2e^{-20t}$  A
30. The circuit shown is based on ideal operational amplifier. It acts as a

- (A) Subtractor  
(B) Adder  
(C) Buffer  
(D) Divider

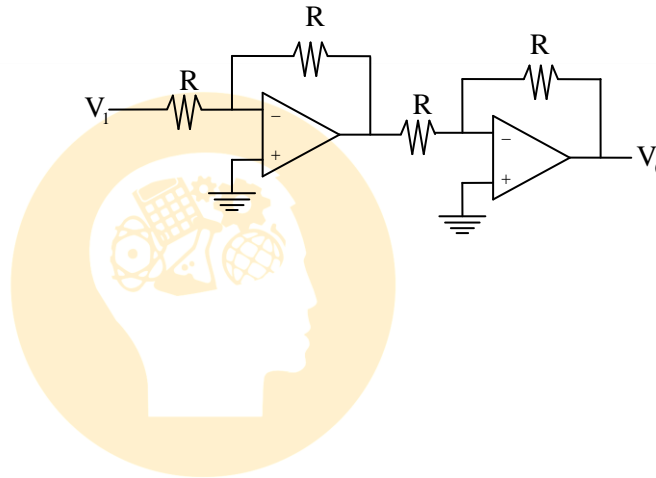

INDIAN ENGINEERING  
OLYMPIAD