

**PAPER-III**  
**ELECTRONIC SCIENCE**

**Signature and Name of Invigilator**

1. (Signature) \_\_\_\_\_  
(Name) \_\_\_\_\_
2. (Signature) \_\_\_\_\_  
(Name) \_\_\_\_\_

OMR Sheet No. : .....  
(To be filled by the Candidate)

Roll No. 

--	--	--	--	--	--	--	--

  
(In figures as per admission card)

Roll No. \_\_\_\_\_  
(In words)

**J 8 8 1 6**

Time : 2 ½ hours]

[Maximum Marks : 150

Number of Pages in this Booklet : 24

Number of Questions in this Booklet : 75

**Instructions for the Candidates**

- Write your roll number in the space provided on the top of this page.
- This paper consists of seventy five multiple-choice type of questions.
- At the commencement of examination, the question booklet will be given to you. In the first 5 minutes, you are requested to open the booklet and compulsorily examine it as below :
  - To have access to the Question Booklet, tear off the paper seal on the edge of this cover page. Do not accept a booklet without sticker-seal and do not accept an open booklet.
  - Tally the number of pages and number of questions in the booklet with the information printed on the cover page. Faulty booklets due to pages/questions missing or duplicate or not in serial order or any other discrepancy should be got replaced immediately by a correct booklet from the invigilator within the period of 5 minutes. Afterwards, neither the Question Booklet will be replaced nor any extra time will be given.**
  - After this verification is over, the Test Booklet Number should be entered on the OMR Sheet and the OMR Sheet Number should be entered on this Test Booklet.
- Each item has four alternative responses marked (1), (2), (3) and (4). You have to darken the circle as indicated below on the correct response against each item.  
**Example :** ① ② ● ④  
where (3) is the correct response.
- Your responses to the items are to be indicated in the **OMR Sheet given inside the Booklet only**. If you mark your response at any place other than in the circle in the OMR Sheet, it will not be evaluated.
- Read instructions given inside carefully.
- Rough Work is to be done in the end of this booklet.
- If you write your Name, Roll Number, Phone Number or put any mark on any part of the OMR Sheet, except for the space allotted for the relevant entries, which may disclose your identity, or use abusive language or employ any other unfair means, such as change of response by scratching or using white fluid, you will render yourself liable to disqualification.
- You have to return the Original OMR Sheet to the invigilators at the end of the examination compulsorily and must not carry it with you outside the Examination Hall. You are, however, allowed to carry original question booklet and duplicate copy of OMR Sheet on conclusion of examination.
- Use only Black Ball point pen provided by C.B.S.E.
- Use of any calculator or log table etc., is prohibited.
- There is no negative marks for incorrect answers.

**परीक्षार्थियों के लिए निर्देश**

- इस पृष्ठ के ऊपर नियत स्थान पर अपना रोल नम्बर लिखिए ।
- इस प्रश्न-पत्र में पचहत्तर बहुविकल्पीय प्रश्न हैं ।
- परीक्षा प्रारम्भ होने पर, प्रश्न-पुस्तिका आपको दे दी जायेगी । पहले पाँच मिनट आपको प्रश्न-पुस्तिका खोलने तथा उसकी निम्नलिखित जाँच के लिए दिये जायेंगे, जिसकी जाँच आपको अवश्य करनी है :
  - प्रश्न-पुस्तिका खोलने के लिए पुस्तिका पर लगी कागज की सील को फाड़ लें । खुली हुई या बिना स्टीकर-सील की पुस्तिका स्वीकार न करें ।
  - कवर पृष्ठ पर छपे निर्देशानुसार प्रश्न-पुस्तिका के पृष्ठ तथा प्रश्नों की संख्या को अच्छी तरह चैक कर लें कि ये पूरे हैं । दोषपूर्ण पुस्तिका जिनमें पृष्ठ/प्रश्न कम हों या दुबारा आये हों या सीरियल में न हों अर्थात् किसी भी प्रकार की त्रुटिपूर्ण पुस्तिका स्वीकार न करें तथा उसी समय उसे लौटाकर उसके स्थान पर दूसरी सही प्रश्न-पुस्तिका ले लें । इसके लिए आपको पाँच मिनट दिये जायेंगे । उसके बाद न तो आपकी प्रश्न-पुस्तिका वापस ली जायेगी और न ही आपको अतिरिक्त समय दिया जायेगा ।
  - इस जाँच के बाद प्रश्न-पुस्तिका का नंबर OMR पत्रक पर अंकित करें और OMR पत्रक का नंबर इस प्रश्न-पुस्तिका पर अंकित कर दें ।
- प्रत्येक प्रश्न के लिए चार उत्तर विकल्प (1), (2), (3) तथा (4) दिये गये हैं । आपको सही उत्तर के वृत्त को पेन से भरकर काला करना है जैसा कि नीचे दिखाया गया है :  
**उदाहरण :** ① ② ● ④  
जबकि (3) सही उत्तर है ।
- प्रश्नों के उत्तर केवल प्रश्न पुस्तिका के अन्दर दिये गये OMR पत्रक पर ही अंकित करने हैं । यदि आप OMR पत्रक पर दिये गये वृत्त के अलावा किसी अन्य स्थान पर उत्तर चिह्नानंकित करते हैं, तो उसका मूल्यांकन नहीं होगा ।
- अन्दर दिये गये निर्देशों को ध्यानपूर्वक पढ़ें ।
- कच्चा काम (Rough Work) इस पुस्तिका के अन्तिम पृष्ठ पर करें ।
- यदि आप OMR पत्रक पर नियत स्थान के अलावा अपना नाम, रोल नम्बर, फोन नम्बर या कोई भी ऐसा चिह्न जिससे आपकी पहचान हो सके, अंकित करते हैं अथवा अभद्र भाषा का प्रयोग करते हैं, या कोई अन्य अनुचित साधन का प्रयोग करते हैं, जैसे कि अंकित किये गये उत्तर को मिटाना या सफेद स्याही से बदलना तो परीक्षा के लिये अयोग्य घोषित किये जा सकते हैं ।
- आपको परीक्षा समाप्त होने पर मूल OMR पत्रक निरीक्षक महोदय को लौटाना आवश्यक है और परीक्षा समाप्ति के बाद उसे अपने साथ परीक्षा भवन से बाहर न लेकर जायें । हालाँकि आप परीक्षा समाप्ति पर मूल प्रश्न-पुस्तिका तथा OMR पत्रक की डुलीकेट प्रति अपने साथ ले जा सकते हैं ।
- केवल C.B.S.E. द्वारा प्रदान किये गये काले बाल प्वाइंट पेन का ही इस्तेमाल करें ।
- किसी भी प्रकार का संगणक (कैलकुलेटर) या लाग टेबल आदि का प्रयोग वर्जित है ।
- गलत उत्तरों के लिए कोई नकारात्मक अंक नहीं हैं ।



**ELECTRONIC SCIENCE  
PAPER – III**

**Note :** This paper contains **seventy five (75)** objective type questions of **two (2)** marks each.  
**All** questions are compulsory.

1. When gate to source voltage of a FET changes from  $-5.2$  volt to  $-5$  volts, the corresponding drain current changes from  $1$  mA to  $1.3$  mA, the transconductance is

- (1)  $29 \mu \text{ mho}$  (2)  $510 \mu \text{ mho}$   
(3)  $1500 \mu \text{ mho}$  (4)  $1620 \mu \text{ mho}$

2. In a JFET the gate to source voltage is given as

- (1)  $V_p \left( 1 - \sqrt{\frac{I_{ds}}{I_{dss}}} \right)^2$  (2)  $V_p \left( 1 + \sqrt{\frac{I_{dss}}{I_{ds}}} \right)^2$   
(3)  $V_p \left( 1 - \sqrt{\frac{I_{dss}}{I_{ds}}} \right)$  (4)  $V_p \left( 1 - \sqrt{\frac{I_{ds}}{I_{dss}}} \right)$

3. The power dissipation in the resistor  $R_4$  of the following circuit will be

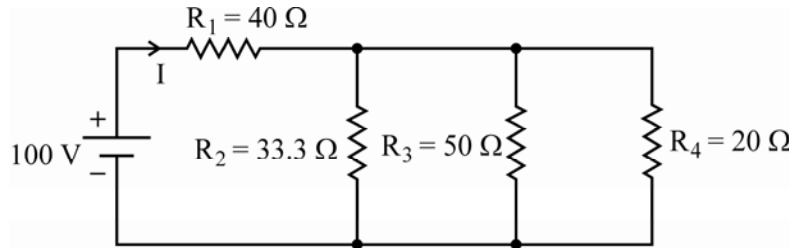

- (1) 10 watts (2) 15 watts  
(3) 20 watts (4) 100 watts

4. A function  $f(t)$  is given by  $e^{-\alpha t} \cos \omega t$ . Its pole location in s-plane will be given by

- (1)
- (2)
- (3)
- (4)

5. For a transistor inverter shown below, if  $I_{C\text{ sat}}$  is 10 mA, the value of  $R_B$  and  $R_C$  are

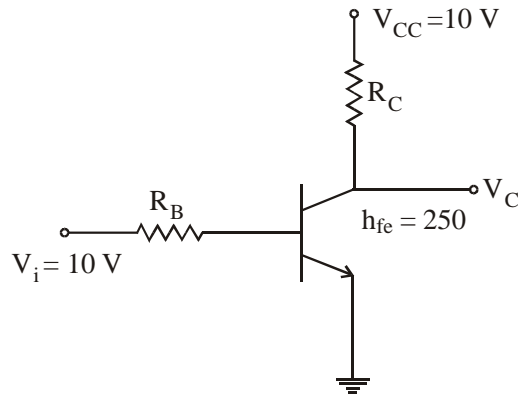

- |                                     |                                       |
|-------------------------------------|---------------------------------------|
| (1) 150 $\Omega$ and 1 k $\Omega$   | (2) 150 k $\Omega$ and 100 k $\Omega$ |
| (3) 155 k $\Omega$ and 1 k $\Omega$ | (4) 155 k $\Omega$ and 10 k $\Omega$  |

6. In a bipolar junction transistor, the collector current is

- |  |   |
|--|---|
| (1) $\frac{I_B}{1 - \alpha_F} + \frac{I_{CO}}{1 - \alpha_F}$ | (2) $\frac{\alpha_F I_B}{1 - \alpha_F} + \frac{I_{CO}}{1 - \alpha_F}$ |
| (3) $\frac{\alpha_F}{1 - \alpha_F} + I_{CO}$                 | (4) $\frac{\alpha_F I_B}{1 + \alpha_F} + \frac{I_{CO}}{1 + \alpha_F}$ |

7. The circuit shown below is a

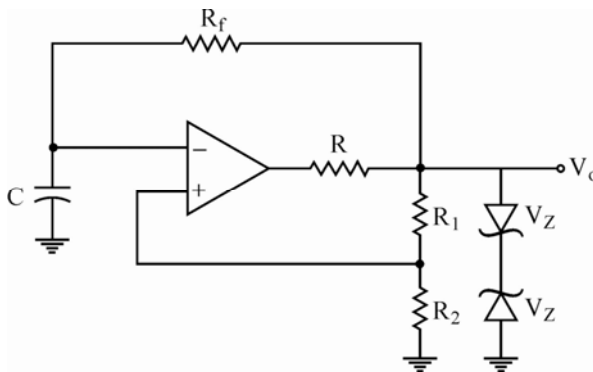

- (1) Free running multivibrator
- (2) Monostable multivibrator
- (3) Comparator
- (4) Schmitt trigger

8. The circuit shown in the figure is equivalent to

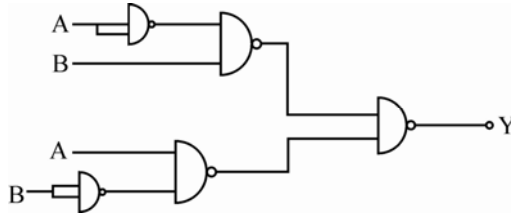

- (1) OR gate
- (2) EX-OR gate
- (3) NAND gate
- (4) AND gate

9. Contents of 'A' register after execution of the following 8085 microprocessor program is

```
MVI A, 55 h
MVI C, 25 h
ADD C
DAA
```

- (1) 22 h
- (2) 50 h
- (3) 80 h
- (4) 7 Ah

10. The ALE line of an 8085 microprocessor is used to

- (1) latch the output of an I/O instruction into an external latch.
- (2) deactivate the chip-select signal from memory devices.
- (3) find the interrupt enable states of the TRAP interrupt.
- (4) latch the 8 bits of address lines AD7-AD0 into an external latch.

11. A constructor is called whenever

- (1) A class is declared.
- (2) An object is declared
- (3) A class is used.
- (4) An object is used.

12. Output of the program given below is

```
int i;
main ( )
{
    printf ("%d", i);
}
```

- (1) 1
- (2) -1
- (3) 0
- (4) Null

13. If  $\lambda$  is the wavelength  $\left(\lambda = \frac{v_p}{f}\right)$  in an unbounded dielectric, then the wavelength  $\lambda_g$  in the rectangular waveguide for  $T_{mn}$  mode is

- (1)  $\frac{\lambda}{\sqrt{1 + \left(\frac{fc}{f}\right)^2}}$  (2)  $\frac{\lambda}{\sqrt{1 - \left(\frac{fc}{f}\right)^2}}$   
 (3)  $\frac{\lambda}{\sqrt{fc + \left(\frac{fc}{f}\right)^2}}$  (4)  $\frac{\lambda}{\sqrt{1 + \left(\frac{fc}{f}\right)^2}}$

14. In a tunnel diode, the degeneracy on the n-side can be expressed as

- (1)  $\frac{kT}{q} \left[ \ln\left(\frac{N_D}{N_C}\right) + 0.35\left(\frac{N_D}{N_C}\right) \right]$  (2)  $\frac{kT}{q} \left[ \ln\left(\frac{N_D}{N_C}\right) - 0.35\left(\frac{N_D}{N_C}\right) \right]$   
 (3)  $\frac{kT}{q} \left[ \ln\left(\frac{N_C}{N_D}\right) + 0.35\left(\frac{N_C}{N_D}\right) \right]$  (4)  $\frac{kT}{q} \left[ \ln\left(\frac{N_C}{N_D}\right) - 0.35\left(\frac{N_C}{N_D}\right) \right]$

15. If 1 MHz carrier is amplitude modulated with a 5 kHz audio signal, the Upper Side Band (USB) and Lower Side Band (LSB) frequencies are \_\_\_\_\_ respectively.

- (1) 1005 kHz & 995 kHz (2) 1.05 MHz & 9.05 MHz  
 (3) 1.5 MHz & 0.95 MHz (4) 1010 kHz & 990 kHz

16. Which one of the following is the Fourier transform of the signal given in Fig. II, if the Fourier transform of the signal in Fig. I is  $= 2 \frac{\sin \omega T_1}{\omega}$  ?

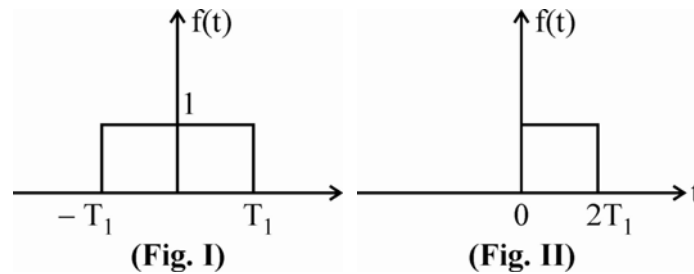

- (1)  $2 \frac{\sin \omega T_1}{\omega} e^{+j\omega T_1}$  (2)  $2 \frac{\sin \omega T_1}{\omega} e^{-j\omega T_1}$   
 (3)  $\frac{\sin \omega T_1}{\omega} e^{-j\omega T_1}$  (4)  $\frac{\sin \omega T_1}{\omega} e^{+j\omega(T_1-2)}$

17. A plastic-clad fiber has similar characteristics as an all-glass fibre except that it is more sensitive to \_\_\_\_\_ damage.

- (1) Corrosion (2) Abrasive  
 (3) Chemical (4) Moisture

18. Which of the following is not a usual classification of optical fibre ?
- (1) Single mode step index                      (2) Single mode graded index  
 (3) Multimode step index                        (4) Multimode graded index
19. The addition of a pole to the forward path transfer function of a closed loop system, generally has the effect of
- (1) Decreasing the maximum overshoot  
 (2) Increasing the maximum overshoot  
 (3) Maintaining the maximum overshoot  
 (4) Does not affect the maximum overshoot

20. The pole-zero configuration of a PI controller is represented by

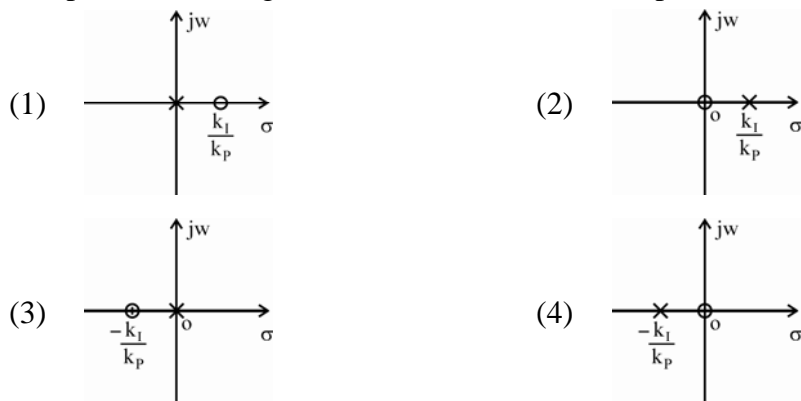

21. In ideal MOS diode

- (a)  $\phi_{ms} = 0$                                       (b)  $\phi_m + \phi_B = \chi + \frac{E_g}{2q}$   
 (c)  $\phi_m - \phi_B - \chi = E_g$                       (d)  $\phi_B + \chi = \frac{E_g}{2}$

Out of the above which are correct ?

- (1) (a) and (b) are correct                      (2) (a) and (c) are correct  
 (3) (b) and (c) are correct                      (4) (a) and (d) are correct

22. The static current voltage characteristics of a tunnel diode consist of

- (a) Tunneling current and thermal current  
 (b) Thermal current and excess current  
 (c) Tunneling current only  
 (d) Tunneling current, excess current and thermal current

Out of these which are correct ?

- (1) (a) and (c) are correct                      (2) (c) is correct but (d) is wrong  
 (3) (d) is correct but (a) is wrong              (4) (b) and (d) are wrong

23. Consider a two-mesh network as shown in the figure :

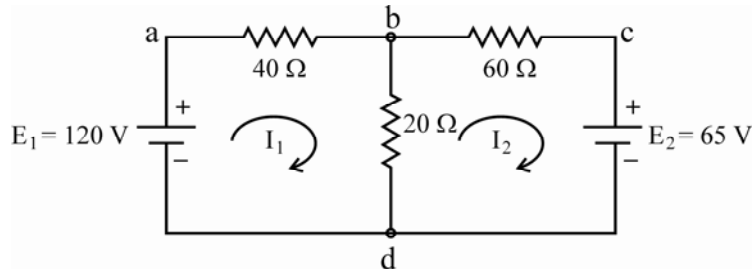

The values of  $I_1$  and  $I_{bd}$  and  $I_2$  are computed as

- (a)  $I_1 = 1.885$  amps,  $I_2 = 0.341$  amps
- (b)  $I_1 = 1.885$  amps,  $I_{bd} = 2.23$  amps
- (c)  $I_2 = -0.341$  amps,  $I_{bd} = 1.885$  amps
- (d)  $I_2 = -0.341$  amps,  $I_{bd} = 2.23$  amps

Which of the above computations are correct ?

- (1) (a) and (b)
- (2) (b) and (c)
- (3) (c) and (d)
- (4) (b) and (d)

24. Read the following statements regarding Thevenin's equivalent circuit :

- (a) The Thevenin's voltage is calculated across the short circuit terminals.
- (b) The Thevenin's voltage is calculated at the open circuit terminals.
- (c) The connection in the circuit is open if any voltage source is present.
- (d) The connection in the circuit is shorted if any voltage source is present.

Which of the above statements are incorrect ?

- (1) (a) and (b)
- (2) (b) and (c)
- (3) (a) and (c)
- (4) (b) and (d)

25. In enhancement mode MOSFET the saturation (drain) current is given by

- (a)  $K \frac{W}{L} (V_{gs} - V_{th})^2$
- (b)  $K \frac{W}{L} (V_{gs} - V_{th}) (1 + \lambda V_{ds})$
- (c)  $K \frac{W}{L} (V_{gs} - V_{th})^2 (1 + \lambda V_{ds})$
- (d)  $K \frac{W}{L} (V_{gs} - V_{th})^2 (1 - \lambda V_{ds})$

Out of these

- (1) (a) and (b) are correct.
- (2) (a) and (c) are correct.
- (3) (b) and (d) are correct.
- (4) (a) and (d) are correct.

26. In a JFET self-bias configuration shown below :

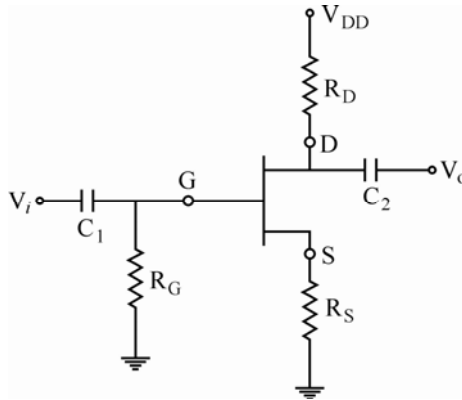

The drain current is

- (a)  $K \frac{W}{L} (V_{gs} - V_{th}) V_{ds}$                       (b)  $I_{DSS} \left(1 - \frac{I_D R_S}{V_P}\right)^2$
- (c)  $I_{DSS} \left(1 + \frac{I_D R_S}{V_P}\right)^2$                       (d)  $K \frac{W}{L} (V_{gs} - V_{th})^2$

Out of these which are correct ?

- (1) (a) and (c) are correct.                      (2) (b) and (d) are correct.
- (3) (b) is wrong but (c) is correct.                      (4) (b) and (c) are correct.

27. For TTL families, following statements are given :

- (a) Speed-frequency product is called figure of merit.
- (b) TTL is most widely used and has 4 sub-families.
- (c) High speed TTL uses smaller resistor and Darlington pair.
- (d) A TTL circuit acts as a current sink in the low state and as a current source in high state.

Out of the above, following is correct :

- (1) (a), (b), (c)                      (2) (c) and (d)
- (3) (a), (c), (d)                      (4) (b), (c), (d)

28. A dual slope A to D converter has the following :

- (a) a differentiator                      (b) a comparator
- (c) an integrator                      (d) a binary counter

Out of above, following is correct :

- (1) (a), (b), (d)                      (2) (a), (b), (c), (d)
- (3) (c), (b), (d)                      (4) (c), (d)



- 29.** Which of the following are true in case of hardware interrupts ?
- (a) They cannot be masked.  
 (b) They are asynchronous events.  
 (c) They are synchronous events.  
 (d) They are requested by external devices.
- (1) (a), (c) and (d)   (2) (a) and (c)  
 (3) (b) and (d)   (4) (c) and (d)

- 30.** Word 20 contains 40  
 Word 30 contains 50  
 Word 40 contains 60  
 Word 50 contains 70
- Which of the following instructions loads 60 into the accumulator ?
- (a) load immediate 60  
 (b) load direct 30  
 (c) load indirect 20  
 (d) load indirect 30
- Which of the above statements are correct ?
- (1) (a) and (c)   (2) (a) and (b)  
 (3) (a) and (d)   (4) (c) and (d)

- 31.** struct date
- ```
{
    int day;
    int month;
    int year;
};
struct
{
    char name [20];
    int sex;
    struct date dob;
} employee, * ptr = & employee;
```
- then year can be accessed by
- (a) employee · dob · year  
 (b) employee · year  
 (c) ptr → dob · year  
 (d) ptr.dob → year
- Which of the above statements are correct ?
- (1) (a) and (b)                                                                   (2) (a) and (c)  
 (3) (b) and (c)                                                                   (4) (c) and (d)

32. A set of names can be represented as a
- (a) one dimensional array of pointers to character
  - (b) a pointer to a character
  - (c) two-dimensional array of characters
  - (d) one-dimensional array of strings

Which of the above statements are correct ?

- (1) (a) and (b)
- (2) (b) and (c)
- (3) (b), (c) and (d)
- (4) (a), (c) and (d)

33. In a p-i-n photodiode the depletion region thickness can be tailored to
- (a) optimize the quantum efficiency
  - (b) optimize the frequency response
  - (c) optimize the quantum efficiency but not the frequency response.
  - (d) optimize the frequency response but not the quantum efficiency.

Out of these

- (1) (a) and (b) are correct
- (2) (a) and (c) are correct
- (3) (b) and (d) are correct
- (4) (a) and (d) are correct

34. In reflex Klystron following statements are given :

- (a) It is used as local oscillator.
- (b) Its efficiency can be calculated by  $\frac{P_o}{V_a I_a}$ .
- (c) Its efficiency can be calculated by  $\frac{P_{ac}}{P_{dc}}$
- (d) Its output depend on repeller and beam voltage.

Out of the above following is correct :

- (1) (a), (c) and (d)
- (2) (a), (b) and (d)
- (3) (a) and (b) only
- (4) (c) and (d) only

35. Which of the following statements are relevant in case of super-heterodyne receiver ?

- (a) RF amplifier in the super-heterodyne receiver improves the rejection of the image frequency.
- (b) Image frequency of a super-heterodyne receiver is rejected by 1 F tuned circuits.
- (c) Image frequency of a super-heterodyne receiver is not rejected by 1 F tuned circuits.
- (d) RF amplifier in the super-heterodyne receiver does not affect image frequency of the signal.

- (1) (a) and (c) are not correct
- (2) (b) and (d) are not correct
- (3) (a) and (c) are correct
- (4) (b) and (d) are correct

36. Which of the following statements are correct ?
- (a) PAM can be detected by a band pass filter.
  - (b) The PWM needs more power than PPM.
  - (c) Noise can be reduced by increasing sampling rate.
  - (d) Pulse code modulation is a digital modulation technique.
- (1) (c) and (d) are correct.                      (2) (a) and (c) are correct.  
(3) (b) and (d) are correct.                      (4) (b) and (c) are correct.
37. Which of the following statements are true for SCR ?
- (a) UJT is a phase controlling device for SCR rectifier.
  - (b) The average load voltage of SCR rectifier is greater than average load voltage of ordinary diode rectifier.
  - (c) Power delivered to the load in SCR rectifier is maximum when SCR firing angle is zero degree.
  - (d) SCR can control the amount of power fed to the load by switching current OFF and ON upto many thousand times a second.
- (1) (a), (b) and (c) are correct.                      (2) (a), (c) and (d) are correct  
(3) (b), (c) and (d) are correct.                      (4) (c) and (d) are correct
38. Losses in optical fibres can be caused due to the following :
- (a) Impurities
  - (b) Microbending
  - (c) Stepped-index operation
  - (d) Electromagnetic interference
- (1) (a), (b) and (c) are correct.                      (2) (a) and (c) are correct.  
(3) (a) and (b) are correct.                      (4) (b) and (d) are correct.
39. Read the following statements regarding errors in measurement :
- (a) Gross errors are mostly due to lack of knowledge and care on the part of the experimenter.
  - (b) Systematic errors are mostly caused by inherent short-comings of the instruments and components used in measurement.
  - (c) Random errors are due to sources and causes that cannot be specified for their effects with.
  - (d) Gross and systematic errors are non-correctable.
- Which of the above are correct ?
- (1) (a) and (b) only                                      (2) (b) and (c) only  
(3) (c) and (d) only                                      (4) (a), (b) and (c) only

40. Consider the following statements with respect to control system :
- (a) For a type '0' system with unit step input, the steady state error is zero.
  - (b) For a type '0' system with unit ramp input, the steady state error is infinite.
  - (c) For a type '1' system with unit step input, the steady state error is zero.
  - (d) For a type '1' system with unit step input, the steady state error is infinite.

Which of the above statements are correct ?

- (1) (a) and (b)
- (2) (b) and (d)
- (3) (a) and (d)
- (4) (b) and (c)

41. Match the following :

**List – I**

- a. Gunn diode
- b. Tunnel diode
- c. BJT
- d. Diode (P-N junction)

**List – II**

- i. degenerate silicon
- ii. n-type Ga As
- iii. Silicon
- iv.  $I_o \left[ \exp \left( \frac{qV}{kT} \right) - 1 \right]$

**Codes :**



- |     |     |    |     |     |
|-----|-----|----|-----|-----|
|     | a   | b  | c   | d   |
| (1) | ii  | i  | iii | iv  |
| (2) | i   | ii | iv  | iii |
| (3) | iii | iv | i   | ii  |
| (4) | iv  | i  | ii  | iii |

42. Match the following lists :

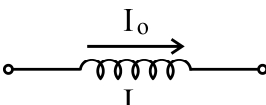
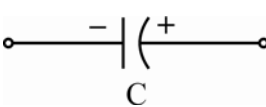
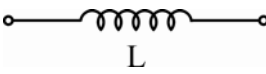
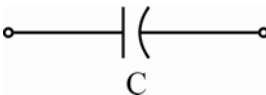
**List – I**

- a. 
- b. 
- c. 
- d. 

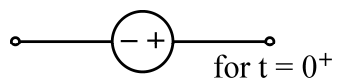
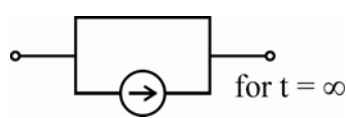
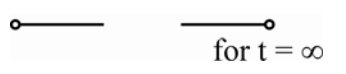
**List – II**

- i. 
- ii. 
- iii. 
- iv. 

**Codes :**

- |     |    |    |     |     |
|-----|----|----|-----|-----|
|     | a  | b  | c   | d   |
| (1) | ii | i  | iv  | iii |
| (2) | ii | i  | iii | iv  |
| (3) | i  | ii | iii | iv  |
| (4) | i  | ii | iv  | iii |

43. Match the following :

**List – I**

- a. Laplace equation
- b. Continuity equation
- c. Current density equation
- d. Poisson's equation

**List – II**

- i.  $q \mu_n \left( \epsilon \cdot n + \frac{k \cdot T}{q} \frac{\partial n}{\partial x} \right)$
- ii.  $Gn - \frac{n_p - n_{p0}}{\tau_n} + n_p \mu_n \frac{\partial \epsilon}{\partial x} + \mu_n \epsilon \frac{\partial n_p}{\partial x} + Dn \frac{\partial^2 n_p}{\partial x^2}$
- iii.  $\frac{\partial^2 \psi}{\partial x^2} + \frac{\partial^2 \psi}{\partial y^2} + \frac{\partial^2 \psi}{\partial z^2} = \frac{qN_D}{\epsilon}$
- iv.  $\Delta^2 \psi = 0$

**Codes :**

- |     | a   | b  | c   | d   |
|-----|-----|----|-----|-----|
| (1) | i   | ii | iii | iv  |
| (2) | iv  | ii | i   | iii |
| (3) | ii  | i  | iii | iv  |
| (4) | iii | i  | iv  | ii  |

44. Match the following lists in terms of power dissipation/Gate:

**List – I**

- a. BiCMOS
- b. ECL
- c. CMOS (AHC)
- d. bipolar TTL (F)

**List – II**

- i. 6 mW
- ii. 2.75  $\mu$ W
- iii. 25 mW to 73 mW
- iv. 17  $\mu$ w

**Codes :**

- |     | a   | b   | c  | d  |
|-----|-----|-----|----|----|
| (1) | i   | iii | iv | ii |
| (2) | iv  | iii | ii | i  |
| (3) | ii  | iii | iv | i  |
| (4) | iii | iv  | i  | ii |

45. Match the following in the context of microprocessor :

**List – I**

- a. Indirect Addressing
- b. Immediate Addressing
- c. Base-register Addressing
- d. Indexed Addressing

**List – II**

- i. Constants
- ii. Relocatable code
- iii. Arrays
- iv. Pointers

**Codes :**

- |     | a   | b   | c   | d   |
|-----|-----|-----|-----|-----|
| (1) | ii  | iii | iv  | i   |
| (2) | iv  | i   | ii  | iii |
| (3) | iii | iv  | i   | ii  |
| (4) | i   | ii  | iii | iv  |

46. Match the following in the context of I/O in C

**List – I**

**List – II**

- |                |      |                                                                                                                                   |
|----------------|------|-----------------------------------------------------------------------------------------------------------------------------------|
| a. getch()     | i.   | returns the character that has been most recently typed and displays the character.                                               |
| b. f getchar() | ii.  | is a macro that returns the character that has been most recently typed and displays the character when return key is pressed.    |
| c. getchar()   | iii. | is a function that returns the character that has been most recently typed and displays the character when return key is pressed. |
| d. getche()    | iv.  | return the character that has been most recently typed.                                                                           |

**Codes :**

- |     |     |     |    |     |
|-----|-----|-----|----|-----|
|     | a   | b   | c  | d   |
| (1) | iii | i   | ii | iv  |
| (2) | i   | ii  | iv | iii |
| (3) | iv  | iii | ii | i   |
| (4) | ii  | iv  | i  | iii |

47. Match the following lists in terms of radiation resistances of various antennas :

**List – I**

**List – II**

- |                                             |      |                                                                |
|---------------------------------------------|------|----------------------------------------------------------------|
| a. Short vertical monopole                  | i.   | $31200 \left( \frac{\text{Area of Loop}}{\lambda^2} \right)^2$ |
| b. Small loop antenna                       | ii.  | $80 \pi^2 \left( \frac{L}{\lambda} \right)^2$                  |
| c. Dipole antenna                           | iii. | 73 ohms                                                        |
| d. Radiation resistance of half wave dipole | iv.  | $400 \left( \frac{\text{Physical height}}{\lambda} \right)^2$  |

**Codes :**

- |     |     |    |    |     |
|-----|-----|----|----|-----|
|     | a   | b  | c  | d   |
| (1) | ii  | i  | iv | iii |
| (2) | i   | ii | iv | iii |
| (3) | iv  | i  | ii | iii |
| (4) | iii | iv | ii | i   |

48. Match the following lists :

**List – I**

**List – II**

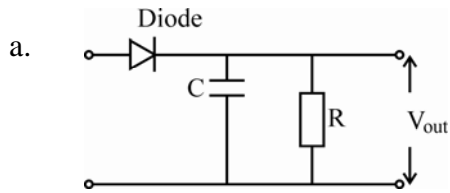

i. Frequency modulated detector

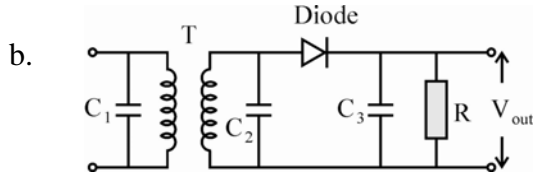

ii. Pre-emphasis

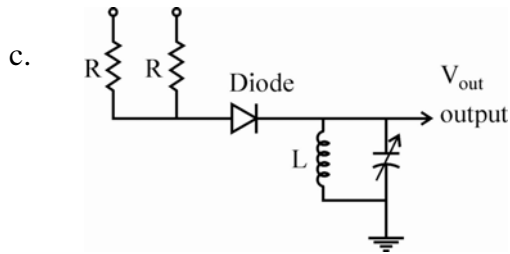

iii. Amplitude modulator

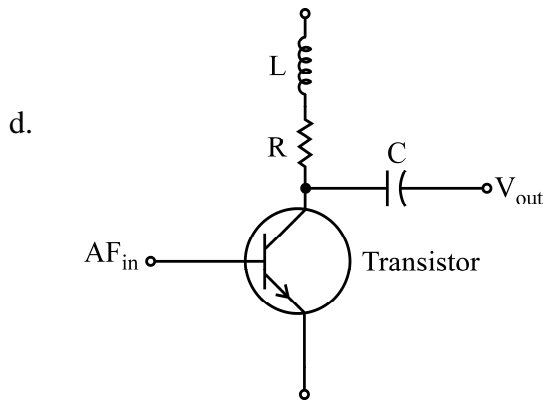

iv. Amplitude detector

**Codes :**

- |     |     |     |     |    |
|-----|-----|-----|-----|----|
|     | a   | b   | c   | d  |
| (1) | iv  | i   | iii | ii |
| (2) | iv  | iii | i   | ii |
| (3) | iii | iv  | ii  | i  |
| (4) | ii  | iii | i   | iv |

49. Match the following lists :

**List – I**

**List – II**

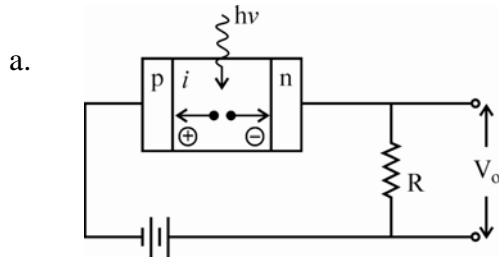

i. Solar cell

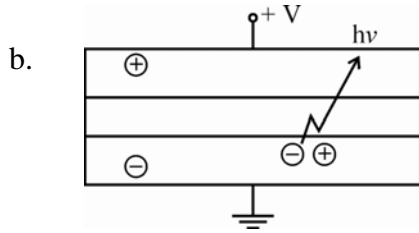

ii. Pn-photodiode

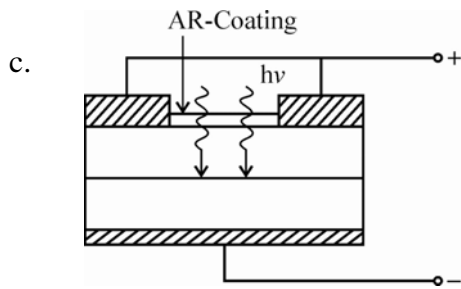

iii. Pin photodiode

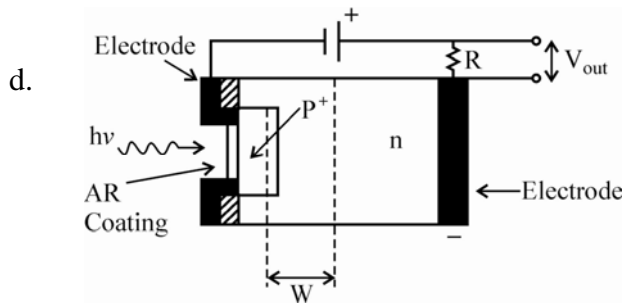

iv. Light emitting diode

**Codes :**

- |     | a   | b   | c  | d   |
|-----|-----|-----|----|-----|
| (1) | ii  | iii | iv | i   |
| (2) | i   | iv  | ii | iii |
| (3) | ii  | iv  | i  | iii |
| (4) | iii | iv  | i  | ii  |



50. Match the following lists :

**List – I**

- a. Electromechanical Device
- b. Optical Device
- c. Gyroscopic device
- d. Absolute motion device

**List – II**

- i. Seismic Device
- ii. Piezo-electric
- iii. Interferometers
- iv. Aerospace vehicle

**Codes :**

- |     |     |     |    |     |
|-----|-----|-----|----|-----|
|     | a   | b   | c  | d   |
| (1) | ii  | i   | iv | iii |
| (2) | i   | iii | ii | iv  |
| (3) | ii  | iii | iv | i   |
| (4) | iii | i   | iv | ii  |

51. Following devices are given :

- (a) transistor in CE stage
- (b) transistor in CB stage
- (c) transistor in CC stage
- (d) Op-Amp

The arrangement of their current gain in ascending order is given by

- |                        |                        |
|------------------------|------------------------|
| (1) (a), (b), (c), (d) | (2) (d), (c), (b), (a) |
| (3) (b), (a), (c), (d) | (4) (c), (d), (a), (b) |

52. Consider the following networks :

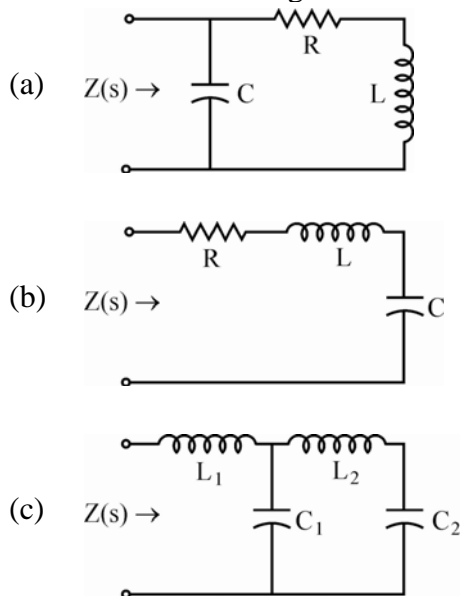

Arrange the above networks in decreasing order of number of poles in Z(s).

- |                   |                   |
|-------------------|-------------------|
| (1) (a), (b), (c) | (2) (b), (a), (c) |
| (3) (c), (b), (a) | (4) (c), (a), (b) |

53. Following are semiconductor materials arrange them in ascending order of their band gaps :
- (a) Si
  - (b) Ge
  - (c) Ga N
  - (d) Ga As

The correct sequence in ascending order is given by

- (1) (c), (d), (a), (b)
- (2) (a), (b), (d), (c)
- (3) (b), (a), (d), (c)
- (4) (d), (c), (a), (b)

54. Arrange the following in terms of decreasing order of power dissipation :

- (a) CMOS
- (b) ECL
- (c) TTL
- (d) MOS

The correct sequence of decreasing order of power dissipation is

- (1) (a), (d), (b), (c)
- (2) (a), (b), (d), (c)
- (3) (b), (c), (d), (a)
- (4) (c), (b), (d), (a)

55. Following are the flag registers of 8085 microprocessors :

- (a) Parity flag
- (b) Carry flag
- (c) Zero flag
- (d) Sign flag

Arrange them in the ascending order starting from LSB to MSB.

- (1) (c), (a), (b), (d)
- (2) (b), (d), (c), (a)
- (3) (b), (a), (c), (d)
- (4) (a), (c), (b), (d)

56. An expression contains the following operators without parenthesis

- (a) relational operators
- (b) assignment operators
- (c) arithmetic operators

Arrange them in the order they are evaluated. The correct option is

- (1) (a), (c), (b)
- (2) (b), (a), (c)
- (3) (c), (a), (b)
- (4) (b), (c), (a)

57. Arrange the following in order of ascending order of frequency :

- (a) W band
- (b) P band
- (c) Q band
- (d) C band

The correct order of sequence is

- (1) (b), (d), (c) and (a)
- (2) (a), (b), (c) and (d)
- (3) (d), (b), (c) and (a)
- (4) (a), (c), (b) and (d)

58. Mention the order of increasing circuit complexity of the below mentioned FM demodulators for the detection of modulating signal from the FM wave :

- (a) Balanced Slope detector
- (b) Slope detector
- (c) Ratio detector
- (d) Phase discriminator

- (1) (b), (a), (c) and (d)
- (2) (b), (a), (d) and (c)
- (3) (d), (b), (a) and (c)
- (4) (c), (b), (a) and (d)

59. Arrange the following network in order of increasing bandwidth and data rate :

- (a) Multimode graded index
- (b) Single mode step index
- (c) Multimode step index

- (1) (c), (b), (a)
- (2) (c), (a), (b)
- (3) (a), (c), (b)
- (4) (b), (a), (c)

60. Consider the following transducers or transducer systems :

- (a) Float elements
- (b) Seismic system
- (c) Gyroscope

Arrange the above transducers/systems in decreasing order of the availability of possible number of output signals.

- (1) (a), (b), (c)
- (2) (a), (c), (b)
- (3) (b), (c), (a)
- (4) (b), (a), (c)

**Directions : Questions 61 to 70**

The following items consist of two statements, one labelled as “Assertion (A)” and the other labelled as the “Reason (R)”. You are to examine the two statements carefully and decide if the Assertion (A) and the Reason (R) are individually true and if so whether the reason is a correct explanation of the assertion. Select your answer to these items using the codes given below and mark your answer accordingly.

**Codes :**

- (1) Both (A) and (R) are true and (R) is the correct explanation of (A).
- (2) Both (A) and (R) are true, but (R) is not the correct explanation of (A).
- (3) (A) is true, but (R) is false.
- (4) (A) is false, but (R) is true.

**61. Assertion (A) :** FET is a device, which depends for its operation on the control of field or voltage due to applied current.

**Reason (R) :** FET has a very high input resistance of the order of mega-ohms. It is also immune to radiations.

**62. Assertion (A) :** Any two terminals of a network composed of linear passive and active circuit elements may be replaced by an equivalent current source and a parallel resistance.

**Reason (R) :** A current source always delivers constant current irrespective of the particular configuration of the circuit to which it is connected.

- 63. Assertion (A) :** The bias instability occurs in transistors due to thermal variations.
- Reason (R) :** The reverse saturation current doubles for every 18 °C temperature rise. Due to this the reverse saturation current further heats the junction. As a result there is a thermal run-away.
- 64. Assertion (A) :** Delay flip flop is used to store a single bit either 0 or 1.
- Reason (R) :** It has only one input, when clock is high and D input is also high, the output resets.
- 65. Assertion (A) :** The default address for starting the execution of the program is from 0000H. This is valid for Intel processors.
- Reason (R) :** The starting address of RAM is from 0000H.
- 66. Assertion (A) :** If a C program contains only one function then it must be main( ).
- Reason (R) :** Because program execution always begins with main( ).
- 67. Assertion (A) :** The ionosphere is that region of the earth's atmosphere in which the constituent gases are ionised by radiations from outer space.
- Reason (R) :** Throughout the ionosphere, there are several layers in which ionization density either reaches maximum or remains almost constant. It depend on the intensity of sun. It also depends upon the atmospheric pressure.
- 68. Assertion (A) :** Signal multiplexing provides medium that allows large number of independent sources to share same physical channel.
- Reason (R) :** It is an aggregate information sent through time division multiplexing.

**69. Assertion (A) :** In the propagation of light along multimode graded index fibre, the rays moving toward the cladding travel longer path with greater velocity than the rays travelling shorter path near the axis of fibres. These cause less spreading as compared to spreading caused by multimode step index fibre.

**Reason (R) :** The velocity varies because refractive index of the multimode graded index fibre increases with radial distance from the centre (axis).

**70. Assertion (A) :** In a well-type manometer, ratio of cross-sectional areas of well and the tube is not the factor that determines the scale of the manometer.

**Reason (R) :** Accuracy of a manometer is not affected by the shape or size of the tubes.

**Q. 71-75 :** Read the passage and answer the following questions :

Engineering measurement techniques have made substantial contributions in the accurate determinations of various physiological parameters, that give useful information to clinicians to detect the mal-functioning of the system being measured and also aid in proper diagnosis and patient care. Some of the biomedical instruments may be designed and developed for a particular specialised requirement but a majority of them are adaptations of widely used physical measuring devices. For monitoring the temperature of biomedical subjects, a thermister device is generally used along with a suitable bridge circuit in which the terminal device may be a voltmeter, calibrated in terms of degrees Celsius or Fahrenheit.

**71.** Blood pressure is measured by

- |                |                        |
|----------------|------------------------|
| (1) Manometer  | (2) Sphygmomanometer   |
| (3) Viscometer | (4) Air bubbler system |

**72.** Electrocardiogram is a graphical representation of electrical activity of heart muscle myocardium, in the form of

- (1) A time varying voltage
- (2) A time varying current
- (3) A time varying pressure
- (4) A time varying blood concentration

**73.** For the quantitative measurement of acidity or alkalinity, the instrument used is

- (1) Hair hygrometer
- (2) Humister hygrometer
- (3) pH meter
- (4) A chromatography

**74.** The amplitude of an electrocardiograph signal is usually of the order of

- (1) 0.001 mV
- (2) 1 mV
- (3) 10 mV
- (4) 20 mV

**75.** In the bio-electric phenomenon, ERG is used to detect

- (1) Electrical activity of the heart
- (2) Electrical activity of the brain
- (3) Retinal activity
- (4) Muscle activity

**Space For Rough Work**